

PSYCHOLOGY IN RUSSIA: STATE OF THE ART

Volume 16 Issue 1 2023

Systematic review

- Bilingualism and Development of Literacy in Children: A Systematic Review 3
Oshchepkova E.S., Kartushina N.A., Razmakhnina K.O.

Psychometrics

- Psychometric Analysis of Two Brief Versions of the CERQ in the Argentinean Population: CERQ-18 and CERQ-27 26
Dominguez-Lara S., Moretti L., Flores-Kanter P.E., Muñoz-Navarro R., Medrano L.A.

Social psychology

- Social Axioms and Individual Values as Predictors of COVID-19 Fear among University Students from Countries with Different Government Strategies for Managing the Pandemic 44
Nadezhda V. Murashcenkova^{a}*
- The Role of Income in System Justification 66
Elena R. Agadullina
- The Relationship Between Perceived Discrimination, Acculturation Attitudes, and Adaptation among Anglophone African Immigrants in Russia: The Moderating Role of Neuroticism 77
Ivande S.K., Ryabichenko T.
- Exploring the Associations between Happiness, Life-satisfaction, Anxiety, and Emotional Regulation among Adults during the Early Stage of the COVID-19 Pandemic in Russia 98
Kornienko D.S., Rudnova N.A.
- Determinants of Russian Attitudes Toward a Green Economy During the COVID-19 Pandemic 113
Maksimenko A.A., Deyneka O.S., Zabelina E.V.

SYSTEMATIC REVIEW

Bilingualism and Development of Literacy in Children: A Systematic Review

Ekaterina S. Oshchepkova^{a*}, Natalia A. Kartushina^{a, b},
Ksenia O. Razmakhnina^c

^a *Lomonosov Moscow State University, Moscow, Russia*

^b *University of Oslo, Oslo, Norway*

^c *Institute of Linguistics, Russian Academy of Sciences, Moscow, Russia*

*Corresponding author. E-mail: oshchepkova_es@iling-ran.ru

Background. The importance of biliteracy in bilingual children's development has been widely investigated and discussed for the last several decades, suggesting beneficial effects of writing and reading in two languages for bilingual children as well as for adult second language learners.

Objective. To analyze research on the link between bilingualism and literacy development in two or more languages and the factors that may influence a successful or problematic biliteracy acquisition. RQ (1): What is the relationship between bilingualism and literacy of bilingual children? RQ (2): What strategies are used to develop biliteracy?

Design. The review analyzes 50 studies of literacy development in bilingual children. The selected articles have been separated based on their methodology: 25 articles gave a critical analysis of more than 1,100 studies on the topic, strengthening the theoretical basis of existing research, and 25 other articles were empirical research articles demonstrating practical evidence for the former.

Results. Our analysis revealed that literacy in bilinguals, or biliteracy, can be seen as a necessary condition for fluent development of bilingualism, though it is not a necessary condition (which is explained by the difference between structures of specific languages and writing systems, instruction in literacy, and cognitive baggage invoked by the task used to measure the skill) (Bialystok, 2002). Research suggests that bilingualism impacts children's ultimate acquisition of literacy via the beneficial effects of bilingualism overall: advanced biliteracy boosts the development of phonological and phonemic awareness and metacognitive abilities. Thus, biliteracy can be considered as an advantage in terms of maintaining bilingual acquisition in general and developing writing skills in particular.

Keywords: Bilingualism, multi-lingualism, biliteracy, writing skills, multilingual education, systematic review

Conclusion. There is a lack of studies on the development of writing skills in different educational contexts, across countries and cultures, which must be addressed and complemented by new empirical research. Research will enable policymakers to improve educational programs in accordance with the needs of bilingual children, who are the majority in the current global population.

Introduction

Written texts are used as symbolic representations of spoken language. The ability to decode such symbols is an acquired skill. Alkhaldi and Oshchepkova (2018) examined the relationship between speaking and literacy (reading and writing), showing evidence for a tight link between the abilities to encode and decode spoken language, as well as their connection to the development of non-verbal cognition.

Day (2015) and Graham (2019) state that writing ability is acquired through extensive reading (ER). Thus, the key factor for writing skill development for both monolinguals and bi-/multilinguals is exposure to reading materials. Orthographic input can lead to improvements in vocabulary, text organization, and spelling (Murphy & Diehm, 2020). Research focused on writing skills must take into consideration reading skills, since they are tightly linked (Hinesly, 2019; Midgette & Philippakos, 2018).

Writing samples help educators assess not only linguistic characteristics of a written text, but also important aspects of phonemic awareness, phonological awareness, metalinguistic knowledge, and general cognitive abilities (Cheung et al., 2011; Cummins, 2021; Gort, 2019; Rubin & Galván, 2005). In addition, researchers define reading skills as high cognitive abilities, but also as a central part of children's socialization from the early age (Barletta et al., 2011; Bialystok, 2001; Peng & Kievit, 2020). Therefore, children's social skills develop not only via speaking, but also via reading and writing acquisition. Literacy skills of bilinguals or multilinguals attract even more attention in research due to the complexity of simultaneous and/or subsequent learning to read and write in two or more languages.

Taking into consideration a considerable range of issues related to multilingual literacy, there is a certain lack of knowledge on the influence of bilingualism on writing skill development and factors affecting literacy development in bilingual children. Most research on bilingual literacy has been performed in natural learning environments, such as schools and academies where children learn reading and writing (Benson, 2017; Cenoz & Gorter, 2011; Evans, 2020; Francis, 1999; Hinesly, 2019). Bilingual education is offered in a number of countries today as an obligatory part of a modern education, with an array of programs offered by different curricula. Despite substantial research on bilingual education and the development of literacy, there are still unresolved issues related to bilingual and/or plurilingual literacy, including their connection to metalinguistic and phonological awareness, non-verbal cognition, cross-linguistic influence, and development of two (or more) writing systems and Cognitive Academic Language Proficiency (CALP) (Cummins, 2021). In addition to research in academic environments, there are also studies focused on the develop-

ment of biliteracy in home environments, including studies on minority language maintenance and parental strategies to acquire L2 while maintaining L1 (Costa & Melo-Pfeifer, 2022; Griva & Chostelidou, 2014; Kenner, 2005; Lee, 2020; Oller et al., 2007; Reese et al., 2008). These studies are mostly focused on the link between such strategies and bilinguals/biliterates' academic performance.

The importance of biliteracy in bilingual children's development has been widely investigated and discussed for the last several decades, suggesting beneficial effects of writing and reading in two languages for bilingual children as well as for adult second language learners. The present study analyzes research on the link between bilingualism and literacy development in two or more languages and the factors that may influence successful or problematic biliteracy acquisition.

RQ (1): What is the relationship between bilingualism and literacy of bilingual children?

RQ (2): What strategies are used to develop biliteracy?

Methods

Identification of Relevant Studies

Given the controversy over the effects of bilingualism on the development of writing skills and cognition, the present paper analyzes research on the development of writing skills in bilingual children. We searched studies with the keywords "biliteracy", "bilinguals", "writing skills", and "development", finding 6,850 articles. Then on the basis of the abstracts, we excluded the studies that were not suitable. The exclusion criteria were the following: (a) studies with adult participants were excluded according to the topic of the research as well as studies with participants who had any specific language impairment (SLI) or studies in which participants lacked the ability to write in L1 when learning to write in L2; (b) studies that repeated the data and the results of earlier research. We have also chosen articles with higher citation by other researchers, as they included a wider analysis than studies that reviewed their conclusions. Fifty articles met our inclusion criteria. So, we analyzed 50 studies on biliteracy development (years of publication are 1979–2022), distinguishing the major topics of interest as presented in Table 1. The selected articles have been separated based on their methodology: 25 articles gave a critical analysis of more than 1,100 studies on the topic, strengthening the theoretical basis of the existing research, and 25 other articles were empirical research articles demonstrating some practical evidence for the former.

Results

We distinguished nine major topics of research in bilingual literacy development, including cognitive skills and brain activity; metalinguistic awareness; phonological and phonemic awareness; the relationship between reading and writing skills; parental strategies and the socio-economic situation of the families; environmental influence, which includes the influence of the neighborhood and the community; education, including bilingual programs or any other schooling experience in L1

Table 1*Topics Discussed in Research on Biliteracy.*

Major issues raised in the research on biliteracy	Examples of studies	Summary of results
Cognitive skills and brain activity (neurolinguistic studies)	Bialystok (2001); Brice & Brice (2009); Cummins (2021); Del Maschio et al. (2020); Deluca et al. (2019); Ma et al. (2020); Marian & Kaushanskaya (2004); Pliatsikas et al. (2020); Ramírez-Esparza & García-Sierra (2014); Soltero-González & Butvilofsky, (2016)	In comparison to poor bilingual writers, good bilingual writers held a broader and more complex view of their own writing process and showed more strategic knowledge, since they were more flexible in using both cognitive and metacognitive strategies and employed a wider range of more “elaborated” strategies.
Metalinguistic awareness	Bassetti (2005, 2012); Bialystok (2001); D’Angelo, F. (2020); D’Angelo & Sorace (2022); Eviatar et al. (2018); Francis (1999); Kenner (2005); Oller et al. (2007); Robinson et al. (2022); Roehr-Brackin (2018); Tabors et al. (2003)	Biliterates differ from monoliterates in their ability to analyze and manipulate language units, and bilinguals who have developed an aspect of metalinguistic awareness through biliteracy can outperform native speakers in one or both of their languages, including a weak second language. Hence, there is a strong connection between metalinguistic awareness and biliteracy.
Phonological and phonemic awareness	Bassetti, (2005, 2012); Bialystok (2002, 2020); Cheung et al. (2011); Gottardo et al. (2011); Khalaf et al. (2019); Limberger et al. (2020); Medeiros et al. (2020); Pawlicka et al. (2018); Tabors et al (2003)	According to the Orthographic Depth Hypothesis, phonological transparency of an alphabetic writing system affects bilinguals’ reading and spelling, as biliterates rely more on grapheme-phoneme conversions for reading and phoneme-grapheme for spelling (i.e., learning to read in two similar writing systems is easier than learning to read in two different writing systems).
Relationship between reading and writing skills	Alkhalidi & Oshchepkova (2018); Bassetti (2012); Bialystok (2002); Cheung et al., (2011); Chung et al. (2019); Eviatar et al. (2018); Gottardo et al. (2011); Kenner (2005); Marian & Kaushanskaya (2004); O’Brien et al. (2019)	Bilinguals’ reading proficiency is a joint result of a language’s orthographic characteristics and instructional methods. Reading and writing involve the same processes in all languages, so good readers in one language tend to be good readers in another, as well as being able to spell in both languages. Some language structures and orthography determine the prerequisite skills that children acquire and the ease with which reading can be acquired. Biliterates tend to map a visual stimulus of one language onto an orthographic representation of both languages, and the lexical representation of non-target language is activated (eye-tracking data).

Parental strategies and SES of the families	Brito et al. (2021); Cobo-Lewis et al. (2002); Fernandes (2019); Goldenberg et al. (2011); Griva & Chostelidou (2014); Kenner (2005); Naeem et al. (2018); Nakamura (2018); Reese et al. (2006, 2008); Reese & Goldenberg (2008)	Home literacy practices predicted reading skills in bilingual children. Though the majority of parents were interested in their children's bilingualism, families with low SES demonstrated a low level of involvement in promoting literacy.
Role of environment (neighborhood, community)	Claussenius-Kalman (2021); Hristo et al. (2017); Oller et al. (2007); Ramos et al. (2022); Reese & Goldenberg (2008); Reese et al. (2006); Tabors et al., (2003); Turdaliyevich (2022)	Bilingualism, when nurtured in well-designed environments of teaching and community, was beneficial for the maintenance of L1 and successful learning of L2. The community's opinion about languages plays a fundamental role in establishing a child's self-confidence about bilingualism as well as biliteracy.
Role of education	Barletta et al. (2011); Benson (2017); Carlisle & Beeman (2000); Cobo-Lewis et al. (2002); Elorza (2013); Gale et al. (1981); Goldenberg et al. (2011); Hinesly (2019); Ifont & Tovar-García (2018); Kenner (2005); Oller et al., (2007); Serna & Hudelson (1993); Uranova et al. (2022)	The type of bilingual program — immersion (target language only); maintenance (or developmental) bilingual instruction (L1 instruction continues after beginning substantial amounts of L2 instruction); dual-language (or two-way) programs (simultaneous bilingualism and biliteracy in both languages) — affects biliteracy acquisition (it can be both positive and negative); school affects students' confidence and self-identification; teachers' beliefs about bilingual/biliteral students' capacities to acquire a subject (there is a prevailing belief that a child's native language is the cause of his/her learning problems).
L1-L2 transfer in writing	Barletta et al. (2011); Cenoz & Gorter (2011); Cummins (2021); Fitzgerald (2006); Genesee (2002); Kiramba, (2017); Lay (1982); Marian et al., (2021); Soltero-González & Butvilofsky (2016); Reese & Goldenberg (2008); Tabors et al. (2003)	Becoming literate in one's L1 helps with literacy development in L2 and vice versa: writing well in one's first language is associated with successful acquisition of writing skills in a second language (due to the process of language transfer).
Personal preferences and self-identification	Butvilofsky, (2016); Denissova et al. (2019); Kiramba (2017); Sabti et al. (2019); Soltero-González, Griva, & Chostelidou (2014)	Bilingual children with a low level of support and encouragement from schools and the community did not feel comfortable about their writing difficulties, among other things. Such children completed tasks unwillingly and did not achieve high scores in comparison to monolinguals.

Note. Languages presented in the studies: English, Spanish, Latin American Spanish, Catalan, Basque, Hakka, Mandarin, Cantonese, Náhuatl, French, German, Arabic, Russian, Gupapuyngu, Albanian, Armenian, Georgian

and/or L2 that may influence literacy acquisition in both L1 and L2; L1–L2 transfer in writing, which includes studies focused on cross-language transfer and the interdependence hypothesis by Cummins (2021). The final topic is personal preferences and self-identification, which includes the psychological state of a biliterate and his/her attitude to “being bilingual and/or biliterate”. Table 1 lists the articles reviewed on these topics and a summary of their results. The *Note* on the languages covered in the reviewed studies demonstrates the breadth of the research, as well as the limitation of existing research (most of the studies dealt with English as one the target languages, rather than other language pairs or multilingual language groups).

Discussion

1. Cognitive Skills and Brain Activity (Neurological Studies)

A critical overview by Barac and Bialystok (2011) showed evidence for a bilingual advantage in cognitive abilities which include executive functions (*e.g.*, attention control, inhibition, task-switching, cognitive flexibility, updating information in working memory). Bialystok (2020) proposes that bilinguals’ cognitive advantage over monolinguals is explained by two factors: (a) bilinguals need to constantly inhibit the linguistic system they are not using at a particular moment; (b) the control, including inhibition, attention, monitoring, and switching, leads to higher development of executive function. Neurological studies have shown that executive control tasks activate the frontal lobe, where Broca’s area is located, the area which is considered as the language-eloquent area and responsible for language processing. Subsequently, bilingualism boosts the development of executive control processes in childhood and adulthood. Older bilinguals show slower cognitive decline than monolinguals in the same processes (Bialystok, 2020).

Brice and Brice (2009), in their research on reading and writing development in bilingual children, identify the differences between brain organization of monolinguals and bilinguals. The organization of language is claimed to vary according to three aspects. The first is the age at which a person becomes bilingual, which is also one of the primary factors influencing bilingual development in general (Brice & Brice, 2009; Grosjean, 1989). Brain imaging research has shown that early biliterates show less separation between language areas in the brain than late biliterates, suggesting that the necessity to accumulate two or more writing systems requires more solid neurolinks between brain areas. This means that the ability to operate more than one language orally and in writing influences the development of brain more heavily. The second aspect is the level of language proficiency, which indicates that more proficient bilinguals show less language separation than less proficient bilinguals. The third aspect that impacts language organization is the brain area itself and the task to be solved. This hypothesis finds support in the study by Chinese researchers Ma et al. (2020), who show that there are significant differences in neural processing related to writing skills in Cantonese–Mandarin bilinguals, depending on the task to be completed in these two languages. These aspects were elaborated in accordance with the Common Underlying Proficiency (CUP) model by Cummins (2021), which postulates that specific neural correlates exist in the bilingual brain and

uphold learning of more than one language. Bialystok (2002) concludes that cognitive performance benefits development of advanced literacy, but is not a major factor affecting biliteracy improvement.

2. Metalinguistic Awareness

Metalinguistic awareness, as an element of cognition, is one of the primary aspects discussed in studies of bilingualism, especially in terms of bilingual development. Research has shown that bilingual children have more elaborated reading strategies than monolingual children, presumably because of bilinguals' higher metalinguistic skills (Bialystok, 2001, 2002).

There is evidence that L2 learners read and write in their L2 differently than native monolingual speakers (Bassetti, 2012; Brice & Brice, 2009; Francis, 1999). This difference has been linked to bilinguals' ability to identify and manipulate linguistic units of two writing systems (Bassetti, 2005). This involves, among other things, bilinguals' ability to identify linguistic patterns of a specific language and to recognize them in another. For instance, word awareness, knowledge of words as linguistic units, helped bilinguals to recognize even non-existing words in a lexical decision task in the experiments of Bassetti (2005) and Marian et al. (2021). Word awareness enables bilinguals to identify words in a written or spoken text and to single out morphemes or phrases as not being "words". On the other hand, it has also been demonstrated that literate speakers, both monolingual and bilingual, tend to be aware of the linguistic units represented in the language or languages they use. Thus, users of alphabetic writing systems are aware of phonemes, while users of syllabic writing systems are aware of syllables (Bassetti, 2005). All in all, bilingual ability to distinguish linguistic units in the language used by a person will depend on the type of writing system used in a particular language.

The connection between biliteracy and metalinguistic awareness was also shown by Francis (1999), who compared 45 bilingual students (languages of usage were Spanish and Náhuatl) in the 2nd, 4th, and 6th grades, their language dominance, reading and writing in their L1 and L2, language awareness, and awareness of sociolinguistic relations. The findings aligned with the theory of Cognitive Academic Language Proficiency (CALP) development of bilinguals (Cummins, 2021), which includes linguistic abilities necessary for understanding academic content), stating that literacy-related skills learned in Spanish were not available when the students were asked to read, write, or speak in Náhuatl. However, the developing ability to control language processing on the level of lexical borrowings reflects a conscious awareness of linguistic forms and structures in both languages. Therefore, the period of instruction in both languages must be taken into account for bilinguals as well as L2 learners. Moreover, in writing tasks, participants showed more active manipulations of language representations confirming (and explaining) the connection between biliteracy and metalinguistic awareness. Research based on Hebrew–Arabic speaking bilingual preschoolers and first-graders confirmed this hypothesis (Eviatar et al., 2018).

However, it needs to be mentioned that a bilingual advantage has mostly been shown in control tasks (*e.g.*, tasks ignoring misleading information) rather than in

analysis tasks (*e.g.*, explicit knowledge of structure). Bialystok (2001, 2002) determines control of attention as a specific cognitive process that is to be taken into consideration, rather than metalinguistic awareness as a whole.

3. *Phonological and Phonemic Awareness*

Phonological awareness, as another element of cognition entailing explicit analysis of speech, strongly predicts reading abilities of bilinguals (Cheung et al. 2011; Gottardo et al., 2011; Khalaf et al., 2019; Limberger et al., 2020; Medeiros et al., 2020; Oller et al., 2007; Pawlicka et al., 2018). Morais (1991) describes true phonological awareness as a concept including “phoneme-level skills only and the conscious reflection on an abstract representation of speech”. Phonological awareness is also described as a specific metalinguistic ability that develops alongside general metacognitive control processes during middle childhood (Turner, 1991, cited in Gottardo et al., 2011).

Bilingualism is strongly associated with greater phonological awareness (Bassetti, 2012; O’Brien et al., 2014). Bassetti (2012) uses the term Orthographic Depth Hypothesis (ODH), which was introduced by Coltheart et al. (1993) in relation to the impact of phonological transparency in an alphabetic writing system on the capacity to read and spell. According to the ODH, users of phonologically opaque alphabetic writing systems rely more on whole-word units for reading and spelling, whereas users of transparent alphabetic writing systems rely more on grapheme-phoneme conversions for reading and phoneme-grapheme conversions for spelling (Coltheart et al., 1993, cited in Bassetti, 2012). The research also supports a view on the reading and writing processes of bilinguals as “writing-system-specific”. This is explained by bilingual-specific skills of interpreting a message from one language to the other, which results in written code-switching (Geva & Siegel, 2000, cited in Bassetti, 2012).

The link between bilingualism and stronger phonological awareness was shown by Oller et al. (2007), who compared phonic abilities and vocabulary knowledge, while controlling for socio-economic status (SES), in 620 Spanish–English bilingual children. The results highlighted the leading role of vocabulary knowledge and advanced phonic abilities in reading and writing. Oller et al. (2007) concluded that phonemic awareness of bilinguals is transferred from their L1 to L2, which can significantly benefit L2 reading acquisition if the two languages use a similar alphabetic system (*e.g.*, Spanish and English). Such generalization has been also confirmed by other studies observing cross-language transfer of graphemic-phonemic mappings for Spanish–English bilinguals beginning to read (Cobo-Lewis et al., 2002).

The variation of writing systems has been shown to affect users’ phonological awareness (Borstrom & Peterson, 1998, cited in Cheung et al., 2011; Lundberg et al., 1980; Manis & Freedman, 2001; Muter et al., 1998). This is explained by the specificity of literacy skills as an effortful activity that requires focused instruction over and above the mere availability of written materials (Bertelson, 1986, cited in Cheung et al., 2011). Therefore, bilingual children are able to establish basic concepts for phonological awareness in any language, irrespective of the type of the writing system; therefore, reading can be facilitated for any language in which the initial literacy acquisition occurs (Bialystok, 2002).

However, that may be true only for Indo-European pairs of languages, due to the lack of research in other languages. Phonemes of some Indo-European languages, including English, map directly onto individual letters or letter combinations. Consequently, efficient reading of English and some Indo-European languages relies on phonological knowledge. Researchers have found that phonological awareness of L1 is linked with the ability to read in L2 as well as L2 phonological awareness is related to L2 reading, although these connections are not always completely overlapping (Geva & Wang, 2001). Language-general linguistic knowledge including phonological awareness, may need to be acquired only while acquiring L1 literacy, though, in this case, L1 proficiency would strongly influence L2 acquisition (Flege et al., 1997). Moreover, phonemic awareness was proved to be developed only with alphabetic literacy development, due to the fact that preliterate bilingual children do not show better results than preliterate monolinguals in phonemic awareness tasks (Bassetti, 2012). If there is a scaffolding effect in phonics from Spanish to English, it could minimize or offset any disadvantage that bilinguals might have as a result of the fact that they have to learn two somewhat different systems of phonics (Labov, 2004). However, there might be a disadvantage of bilingualism in terms of phonological and phonemic awareness, since L2 written representations can affect L2 pronunciation, leading to phoneme addition, deletion, and substitution.

4. Relationship between Reading and Writing Skills

The current review has shown that most of the studies tend not to separate reading and writing skills, but analyze them as a whole in the form of literacy skills (Brice & Brice, 2009; Carlisle & Beeman, 2000; Cheung et al., 2011; Chung et al., 2019; Eviatar et al., 2018; Francis, 1999; Goldenberg et al., 2011; Kenner, 2005; Marian et al., 2021; O'Brien et al., 2019; Oller et al., 2007; Reese & Goldenberg, 2008; Rubin & Galván, 2005; Tabors et al., 2003). Bialystok (2002) explains this connection by saying that “a crucial preparation for literacy is establishing the forms of the writing systems as symbolic knowledge capable of representing meanings” (p. 178), due to the fact that bilingualism may change the way in which biliterates represent linguistic transformation from oral into written form and vice versa.

According to Bialystok (2002), L2 literacy and the precursors in L1 literacy are interrelated through their common concepts. The first is oral proficiency in the target level, which is important in addition to the general proficiency in either of the languages (both L1 and L2). The second is the representational level for writing concepts that include conscious understanding of writing symbols and their connection with the reality in which the individual's vision of the world is situated. The third are the metacognitive processes and strategies for reading developed by the individual, which were mentioned above as among the cognitive abilities enhanced by bilingualism.

Cheung et al. (2011) also indicated a tight link between the development of reading and writing skills in bilinguals' L1 and L2: “reading proficiency is a joint result of orthographic and instructional methods” leading to a cross-language transfer with the transfer of reading to writing skills and vice versa (p. 182). This idea is supported by an empirical study by Carlisle and Beeman (2000), where 36 first-grade students

were examined for their reading and writing skills in English and Spanish. Seventeen students were taught in English for the first grade, whereas the other 19 students were taught in Spanish during their first year of education. The children's text comprehension was assessed by measures of listening and reading comprehension in Spanish and English. Writing samples were evaluated for productivity, linguistic complexity, spelling, and discourse. The study demonstrated the connection between the means and the language of instruction and the development of biliteracy. Instruction in Spanish, as the students' L1, made a significant contribution to the development of students' Spanish reading, in comparison to the group who received instruction in English (their L2). Moreover, the Spanish class wrote longer main clauses with greater use of modifiers, and wrote more elaborated stories in Spanish. Thus, the results showed that in terms of bilingual development, progress depends on the language of instruction and on exposure to literacy activities in students' both native languages (Spanish and English here), as well as the direct connection between (highly-developed) reading and writing skills.

5. Parental Strategies and Socio-Economic Status (SES) of the Families

Parental influence on bilingual language acquisition has been repeatedly demonstrated in the literature. One of the most frequently discussed issues was parental input/reaction with respect to children's code-mixing (e.g., hybridization of two languages, applying units from one language while using the other one). Genesee (2002) suggested the necessity of a "more serious research attention to parental input in the form of bilingual mixing as a possible source of influence in children's mixing". However, parental strategies as an influential source of bilingual children's development are mainly discussed in terms of the development of oral skills or do not differentiate between oral and literacy skills (Brito et al., 2021; Fernandes, 2019; Genesee, 2002; Naeem et al., 2018; Nakamura, 2018). Bilinguals' parents play an enormous role in building a child's self-confidence in being bilingual and biliterate. Parental impact on the child's self-esteem occurs via their awareness of the importance of speaking two (or more) languages, as well as having access to two (or more) cultures. Parents are also responsible for supporting their children's progress in the two languages, rather than being focused on accuracy and correcting their children's mistakes. Finally, parents must show their bilingual children that learning and speaking two languages is something positive (Baker & Sienkewicz, 2000).

Therefore, parents primarily establish the child's bilingual identity and create the environment for bilingual development including his/her literacy skills in both languages. Griva and Chostelidou (2014) examined 32 pupils in Greece (M age = 11.4 years, $SD = 0.45$) from Albanian, Georgian, Russian, and Armenian families who had moved to Greece in their early childhood. The children attended a Greek school where they were learning Greek as their L2 and also English as their foreign language. All of the children were categorized as early bilinguals, while their parents, who also participated in the study, were defined as late L2 learners, as they had spent 2–15 years in Greece. The study inspected writing strategies used by these children while using Greek as their L2, and their parents' views on their children's

bilingual and biliterate abilities and their attitude to their involvement in their children's education.

The majority of participants revealed their positive attitude to their biliteracy and ability to express their thoughts in Greek rather than in their L1. Even when the children faced some difficulties in L2 vocabulary or structuring the desirable form of the text, they showed a capacity to adjust the message by making the ideas simpler or less precise or by using a synonym. The participants also commented on their composing process, stating that they were able to generate the ideas while writing in L2 and employing cognitive strategies (*e.g.*, drafting, translating, composing without a draft) simultaneously. Children with poorer writing skills were mostly concerned about correct spelling and using the appropriate vocabulary, whereas children more skilled in writing demonstrated their readiness in the processes of identifying difficulties and self-correction. All participants were aware of their writing problems and used certain compensation strategies to overcome them. The authors connected the abilities to identify obstacles to writing and overcome them with high flexibility in the bilingual children's use of cognitive and metacognitive strategies and employment of a wide range of more "elaborated strategies" (Griva & Chostelidou, 2014).

As for the parental views, the results indicated that although the majority of parents cared about their children's education, they demonstrated low levels of involvement in it. The authors explain this phenomenon by parents' low self-esteem, as immigrants. This was particularly experienced by parents who had been living in Greece for less than five years and showed their lack of confidence in using Greek, and unfamiliarity with the school system and culture. The authors also noticed a low level of school support for immigrant families, which might discourage them from getting actively involved in the education of their children (Griva & Chostelidou, 2014).

High influence of the family on biliteral acquisition was also shown by Grunow et al. (2008), who examined 632 Spanish-speaking children in 14 Texas schools (the USA). The authors aimed to understand the relationship between the community and the family in terms of the language used by the children and their literacy opportunities. The results of this study revealed a relationship between the literacy skills in children and their families' socio-economic status: "access to reading material (aside from what was provided by the school) was limited overall, especially in families living in lower-income areas where few books and magazines were available for purchase in local stores" (Grunow et al., 2008: p. 287). To summarize this line of research, we can conclude that parental attitudes and involvement in their children's education, and the psychological and economic situation of the family, affect bilingual language acquisition as a whole and biliteral acquisition in particular.

6. Role of the Environment (Neighborhood, Community)

As mentioned above, the family plays a crucial role in building the bilingual child's confidence. The role of the community has been examined mainly in connection with parental strategies that might influence bilinguals' language development. Reese et al. (2008), in their study of Spanish-English bilingual children in Texas, reported

that communities tend to offer a variety of opportunities for children to “hear, see, and use” both English and Spanish (the target language in the study) for a variety of purposes: language use in the community and at home, literacy opportunities in the community, extension of literacy use at home, and the domains of functional literacy uses in which children participate or have an opportunity to observe. Thus, a community with a wide range of bookshops, libraries, churches, events involving the use of literacy skills offers more opportunities for bilinguals to develop their literacy skills, particularly if the authorities are aware of the immigrants’ needs (Reese & Goldenberg, 2008; Reese et al., 2008).

A critical review by Gottardo et al. (2011) suggests that the authorities are responsible for the situation in which immigrants are placed in their territories: “low SES contributes to poor L1, and L2 language and literacy performance”. The authors discuss immigration policy in Canada, as an example of more successful management of immigration flows. In order to move to Canada, a candidate has to provide information about his/her educational status, work experience, personal wealth, as well as knowledge of one of Canada’s official languages. These criteria are decisive when granting a residential permit for potential candidates to move to Canada, which in response, provides a newcomer with the state support necessary for the development of bilingual and biliteral skills.

The results of the analysis indicate that contextual and demographic factors also mediate the relationship between phonological awareness and reading in bilinguals (Gottardo et al., 2011), as well as the educational programs and attitudes towards bilinguals in the community. Family cohesion was shown to mediate the relationship between bilingual dominance and results of a reading test in the study of Latinx immigrant students (Ramos et al., 2022).

7. Role of Educational Setting

As mentioned above, the academic setting has a strong effect on the development of writing skills in both monolingual and bilingual students. In terms of multilingual education, Elorza (2013) noted that “teaching more than two languages contributed to schools aiming at building multilingualism and multiliteracy”. Globally, the promotion of multilingual education in schools is growing, calling for more elaborated and approved academic programs. However, taking into consideration bilingual education as a whole, it has been claimed that whatever the method chosen for a specific type of schooling, listening, speaking, reading, and writing are generally taught on equal terms, regardless of the target language or the type of educational program (Elorza, 2013). This observation is in line with the principles of Cummins’s interdependence hypothesis: languages develop interdependently by a transfer of skills and metalinguistic knowledge from one language into another, which is administered by general language competence that does not depend on a particular language (Cummins, 2021).

However, Benson (2017) gives a critical view of the current situation in multilingual education in low-income countries. She criticizes multilingual education for its focus on globally accepted and promoted languages, leaving minority languages aside, which causes a problem of “compromising the recovery and promotion of lan-

guages that have been lost or partially lost due to political and/or social repression” (Benson, 2017; p. 106).

As for the diversity of bilingual education, four types of instructional programs for bilinguals are generally distinguished: L2-only instruction (or L2 immersion); early transition (literacy and academic skills are acquired in the home language for the first years of elementary school, then transition to L2-only instruction takes place); maintenance (or developmental) bilingual instruction (beginning and continuing with L1 instruction even after starting to receive substantial amounts of instruction in L2); dual language (or two-way) programs (L1 and L2 speakers receive instruction in both languages — bilingualism and biliteracy are acquired for both groups in both languages) (Goldenberg et al., 2011). Additionally, Content and Language Integrated Learning (CLIL) programs have been shown to play a crucial role in developing L2 academic skills, including L2 acquisition, as well as in maintaining L1.

Cummins (2021), analyzing factors that can influence studies of academic differences in bilingual and monolingual students, distinguished linguistic, socio-cultural and “school program” factors. Teaching approaches in bilingualism have been widely researched (Barletta et al., 2011; Benson, 2017; Carlisle & Beeman, 2000; Forsyth, 2014; Gale et al., 1981; Goldenberg et al., 2011; Hinesly, 2019), and two of them have been discussed more extensively: the dual-language method, which is a two-way bilingual program implementing additive bilingualism; and the method of immersion, implementing subtractive bilingualism (Hinesly, 2019). Speaking of analyzing writing skills in both languages of a bilingual, it is important to look at common characteristics of the written languages such as text structure, organization of content, linguistic functions, and rhetorical resources within a range of text genres (Francis, 1999; Hinesly, 2019). Thus, the characteristics of a story, letter, or essay presented in one language will be applied and will evolve further in other languages of a bilingual/multilingual. Subsequently, exposure to different text genres — not to mention common characteristics relating to text structure, organization of content, functions, and rhetorical resources within the text, regardless of the language in which the exposure occurs — will be ultimately implemented throughout the linguistic background of an individual (Elorza, 2013).

This type of bilingual instruction was illustrated by the quasi-experimental study by Hinesly (2019), who compared writings of monolingual and bilingual students at the University of Texas (Spanish and English). Importantly, the writings were not evaluated for content but for mechanics, clarity, language, and the whole structure of the text. The result was that monolinguals outranked bilinguals in structure and organization, but bilinguals outperformed monolinguals in grammar and language use. This supports previous research on general bilingual advantage in such areas as grammar usage, ability to determine appropriate content, and language command. Moreover, Hinesly (2019) concluded that the method of immersion in bilingual education (L2-only focused) is unsatisfactory in comparison to fully bilingual approaches that support fluent bilingualism. Consequently, via a correctly chosen teaching approach, students develop plurilingual competence, which is proficiency in multiple languages with a capacity to efficiently use appropriate language to fulfil the tasks necessary in each specific context, including academic ones (Hinesly, 2019).

Another study of writing skills acquisition in bilingual programs was conducted by Gale et al. (1981). The study included 27 students from two bilingual programs: 15 students received literacy instruction in their L1 first (Gupapuyngu), then began receiving instruction in their L2 (English); 12 students from a submersion group received all their instruction in L2, without building L1 literacy. When examining writing samples of the participants, the authors found that those students who had received L1 literacy instruction before switching to L2 instruction wrote papers of higher quality than those in the submersion group. This paper raises some questions on how the children were instructed, in order to understand what other factors might have influenced the results. Still, this study raises the necessity for more detailed research on the inter-relationship between bilingual instruction and development of writing skills.

Generally, people learn the writing system of their language at an early age in primary school, but this may differ for bilinguals and multilinguals. Kenner (2005) and Hinesly (2019) distinguish culturally different approaches to teaching handwriting in English, Chinese, Arabic, Spanish, and other languages, specifically in languages with differing scripts. As far as teaching bilinguals to use different writing systems is concerned, Kenner (2005) suggests that “bilingual children are considered flexible learners who make good use of their learning experience”: they transfer academic skills learned in one language to another, making connections and using all their linguistic resources to express a thought. Thus, the suggestion that writing is impossible without reading is true, and while learning to write, an individual learns to read. On the other hand, learning to read does not necessarily involve writing, but it does involve acquaintance with writing systems represented by a certain language (Bassetti, 2012). Therefore, through a well-chosen and established curriculum, a bilingual or a multilingual can successfully develop academic and bi-/multiliterate skills.

8. L1-L2 Transfer in Writing

Bialystok (2002) found that bilingualism can play an important role in learning to read if language-specific skills transfer across languages, because some linguistic structures and orthography, in particular, determine the prerequisite skills to be acquired (Geva & Siegel, 2000, cited in Bialystok, 2002; Goswami, 1999). Therefore, biliterate children acquiring the same script in both languages will find it easier to read and write in their languages rather than biscriptal children learning to use two different scripts for their languages (Bialystok, 2001, 2002; Soltero-González & Butvilofsky, 2016).

Cenoz and Gorter (2011) reported “multi-directionality in language transfer” when comparing multilinguals’ writings in Spanish, Basque, English, and French. Multilingual learners use their languages in multiple directions, transferring not only from L1 to L2, but also from L2 to L1. Furthermore, multilinguals tend to use the same general strategy of writing and focus on the same themes to approach the task, but they tend to use different modes of communication in informal writing, encouraging multi-modal literacy. The authors concluded that real literacy practices need to include “trans-languaging, code-mixing and code-switching” since it is desirable to benefit from all the languages an individual uses, so that what is learned

in one language can be easily transferred to (an)other language(s) as well (Cenoz & Gorter, 2011).

Code-switching and code-mixing are considered to play an important role in the acquisition of bilingual writing skills. The effects of cross-linguistic transfer, within-language transfer, and cross-linguistic influence have been recently discussed by Marian et al. (2021), who suggested that cross-linguistic influences on initial vocabulary learning could have “cascading effects on the makeup of one’s later vocabulary” (p. 2). During the acquisition of new vocabulary, a learner is affected by the languages he/she knows, and the initial similarity of some words or patterns can have dynamically changing consequences over the course of word learning as well as usage, both in oral and written communication.

9. Personal Preferences and Self-Identification

Research has shown a relationship between the development of bilingual competence and the psychological state of a bilingual (Griva & Chostelidou, 2014; Kiramba, 2017; Soltero-González & Butvilofsky, 2016). Positive attitudes to the ability to control two or more languages reflect on the more elaborated and freer usage of the languages. Ferris and Politzer (1981) analyzed writing samples of 60 bilingual (English and Spanish) students from California. One-half of the participants had begun U.S. public instruction from the very first year of primary education, whereas the other half had been born and begun their education in Mexico. The results showed that despite some insignificant differences in writing abilities in their L2, the participants from the second group did not possess any demonstrably lower English skills than the first group. Moreover, the students had more positive attitudes toward school and school achievement, and seemed more highly motivated in the schools where school achievement and teachers were highly valued. Thus, the self-esteem of a student, both monolingual and bilingual, is affected by school and educators.

The influential role of schools and teachers in the development of bilingualism was discussed above; we notice that they also play an important role in self-esteem. A biliterate with higher self-confidence will more likely use his/her linguistic resources to express himself/herself, whether in written or oral communication. Cenoz and Gorter (2011) carried out research with 165 secondary students learning Spanish or Basque as their L1 and Basque or Spanish as their L2, correspondingly, and English or French as their L3. Although Cenoz and Gorter discussed the role of code-switching in the writing samples of the participants, they also found that multilingual students who identify themselves as competent users of two or more languages are able to encourage multimodal literacy. This was specifically noticed in terms of language mixing in informal writing, when the students used not only different languages in one piece of writing, but different models of communication to make the message more emotional and stronger (Cenoz and Gorter, 2011). It may be therefore concluded that self-identification as a bilingual and/or biliterate boosts a bilingual’s self-esteem in fluent and autonomous language use.

The importance of personal preferences in writing for biliteracy development was also illustrated in a study by Kiramba (2017), which examined writing practices of

bilingual students in a rural school in Kenya. In this study, 28 multilingual students, speaking one or two more other languages in their families and/or neighborhoods, were learning Kiswahili and English at school. The multilingual community and school instruction in English made the use of more than one language valuable both orally and in writing. The results of the study indicated that “bi/multilinguals’ learning is maximized when they are allowed and enabled to draw from their previously acquired language skills rather than being constrained and inhibited from doing so by monolingual instructional assumptions and practices” (Hornberger, 2005, p. 607). The participants’ self-esteem was heightened by this, and as was shown in the writing samples, the participants meshed semiotic resources for their identities and interests (Canagarajah, 2013). Consequently, psychological well-being was linked with school achievements, which were supported by the community and family; a combination of these factors affected bi/multilinguals’ self-identification and language development and biliteracy in particular.

In our critical review, one controversial issue about the relationship between bilingualism and literacy remained unexplored. This is the negative effect of bilingualism on literacy acquisition. The view that bilingualism has a negative effect was predominant until the middle of the 20th century (for details, see Zinchenko et al., 2019). In recent years, there has been some evidence that such an effect takes place (Brzdęk & Brzdęk, 2021). However, our analysis shows that a negative effect is observed mainly in children with SLI and other difficulties, and SLI is among the exclusion criteria for our review. Besides, Bialystok says that “there is no evidence for harmful effects of bilingual education and much evidence for net benefits in many domains” (Bialystok, 2018, p. 666). Thus we considered it possible in this review to avoid a detailed consideration of a negative effect of bilingualism.

Conclusion

Literacy, as a metacognitive process and socio-cultural concept in general, affects how people analyze and manipulate language units represented in writing system(s) in order to achieve their communicative purpose. Written language provides a permanent graphic representation of a language, by segmenting a message into patterns and depicting some aspects of a language that are not present in its spoken modality. Moreover, preliterate bilingual children are no better than preliterate monolingual children in their phonemic awareness, though even very young children are able to differentiate their writing systems and describe how they work (Bassetti, 2012; Kenner, 2005). Biliterates tend to mix their writing systems in order to achieve a humorous effect or to affirm their identity. What is important to remember for schools and academies aimed at promoting multilingual education, is that biliteracy can affect both L2 and L1 production and comprehension.

Thus, the beneficial effects of biliteracy depend primarily on the relationship between the bilingual’s writing systems. Evidence has been found that biliterates are mostly facilitated when their two writing systems are similar (Bassetti, 2012). In accordance with the Interdependence Hypothesis and the BIA+ model (the upgraded version of the Bilingual Interactive Activation model developed by Dijkstra & Van

Heuven, 2002, and used for understanding the process of bilingual language comprehension, which, according to the model, consists of the word identification subsystem and task/decision subsystem), the writing and reading processes of the L1 writing system affect L2 reading and writing, since literacy skills in one writing system can be used and are more likely to be used when reading and spelling in the other system (Dijkstra et al., 2019; Dijkstra & Van Heuven, 2002; Jacquet & French, 2002; Koda & Zehler, 2007; Van Heuven et al., 1998).

Therefore, biliteracy might benefit the harmonious development of bilingualism, but is not a sufficient condition (due to the structure of specific languages and writing systems, exposure to instruction in literacy, and cognitive skills) (Bialystok, 2002). Bilingualism inevitably impacts children's ultimate acquisition of literacy, due to the beneficial effects of bilingualism as a whole, so that advanced biliteracy boosts the development of phonological and phonemic awareness and metacognitive abilities. Thus, biliteracy can be considered as an advantage in maintaining L2 acquisition in general and developing writing skills in particular.

Limitations

We need more studies on the development of biliteracy concerning languages other than English, and other language pairs with different writing systems and/or scripts. There is an obvious lack of studies related to the development of writing skills in different educational contexts, which must be fulfilled and extended with new research. This will give educational programs an opportunity to improve their curricula in accordance with the needs of bilinguals who are becoming the majority of the global population.

Ethics Statement

As this is an overview article, it does not require ethics approval nor informed consent from the participants.

Author Contributions

E.O. conceived of the idea. K.R. and E.O. developed the theory and performed the review. N.K. verified the analytical methods. All authors discussed the results and contributed to the final manuscript.

Conflict of Interest

The authors declare no conflict of interest.

Acknowledgements

This research was supported by Russian Science Foundation (Project No. 21-18-00581).

References

- Alkhaldi, A., & Oshchepkova, T. (2018). How to develop writing skills in a foreign language? *European Journal of Foreign Language Teaching*, 8(4), 174–185. <http://doi.org/10.5281/zenodo.1647022>
- Baker, C., & Sienkewicz, A. (2000). *The care and education of young bilinguals: An introduction for professionals*. Multilingual Matters.
- Barac, R., & Bialystok, E. (2011). Cognitive development of bilingual children. *Language Teaching*, 44(1), 36–54. <https://doi.org/10.1017/S0261444810000339>
- Barletta, M.L., Klingner, J.K., & Orosco, M. (2011). Writing acquisition among English language learners in U.S. schools. In A. Durgunoglu & C. Goldenberg (Eds.), *Language and literacy development in bilingual settings* (pp. 210–243). Guilford Press.
- Bassetti, B. (2005). Effects of writing systems on second language awareness: Word awareness in English learners of Chinese as a foreign language. In V. J. Cook & B. Bassetti (Eds.), *Second language writing systems* (pp. 335–356). Multilingual Matters. <https://doi.org/10.21832/9781853597954-015>
- Bassetti, B. (2012). Bilingualism and writing systems. In T.K. Ritchie & W.C. Bhatia (Eds.), *Handbook of bilingualism and multilingualism* (2nd edition) (pp. 649–670). John Wiley & Sons. <https://doi.org/10.1002/9781118332382.ch26>
- Benson, C. (2017). Multilingual education for all: Applying an integrated multilingual curriculum model to low-income contexts. In H. Coleman (Ed.), *Multilingualism and development (selected proceedings of the 11th Language & Development Conference, New Delhi, India, 2015)* (pp. 101–114). British Council.
- Bialystok, E. (1991). Letters, sounds, and symbols: Changes in children's understanding of written language. *Applied Psycholinguistics* 12(1), 75–89. <https://doi.org/10.1017/S0142716400009383>
- Bialystok, E. (2001). *Bilingualism in development: Language, literacy, and cognition*. Cambridge University Press. <https://doi.org/10.1017/CBO9780511605963>
- Bialystok, E. (2002). Acquisition of literacy in bilingual children: A framework for research. *Language Learning*, 52(1), 159–199. <https://doi.org/10.1111/1467-9922.00180>
- Bialystok, E. (2018). Bilingual education for young children: Review of the effects and consequences. *International Journal of Bilingual Education and Bilingualism*, 21(6), 666–679. <https://doi.org/10.1080/13670050.2016.1203859>
- Bialystok, E. (2020). Bilingualism at school: Effect on the acquisition of literacy. In P. Griffiths, A.J. Merrison, & A. Bloomer (Eds.), *Language in use. A reader*. Routledge. (pp. 190–199). <https://doi.org/10.4324/9781003060994-19>
- Brice, A.E., & Brice, R.G. (2009). Reading and writing development for bilingual children (L1 and L2). In A.E. Brice & R.G. Brice (Eds.), *Language development: Monolingual and bilingual acquisition* (pp. 266–288). Allyn & Bacon.
- Brito, N.H., Greaves, A., Leon-Santos, A., Fifer, W.P., & Noble, K.G. (2021). Associations between bilingualism and memory generalization during infancy: Does socioeconomic status matter? *Bilingualism: Language and Cognition*, 24(2), 231–240. <https://doi.org/10.1017/S1366728920000334>
- Brzdęk, E., & Brzdęk, J. (2021). On the supportive role of the Warnke Method in improving the phonological competence of a bilingual girl. *Education Sciences*, 11(9), 498. <https://doi.org/10.3390/educsci11090498>
- Canagarajah, A.S. (2013). *Writing as translanguaging practice in academic contexts*. Taylor & Francis. <https://doi.org/10.4324/9780203120293>
- Carlisle, J.F., & Beeman, M.M. (2000). The effects of language instruction on the reading and writing achievement of first-grade Hispanic children. *Scientific Studies of Reading*, 4(4), 331–353. https://doi.org/10.1207/S1532799XSSR0404_5
- Cenoz, J., & Gorter, D. (2011). Focus on multilingualism: A study of trilingual writing, *The Modern Language Journal*, 95(3), 356–369. <http://doi.org/10.1111/j.1540-4781.2011.01206.x>
- Cheung, H., McBride-Chang, C., & Tong, X. (2011). Learning a nonalphabetic script and its impact on later development of English as a second language. In A. Durgunoglu & C. Goldenberg (Eds.), *Language and literacy development in bilingual settings* (1st ed.) (pp. 168–187). The Guilford Press.

- Chung, S. C., Chen, X., & Geva, E. (2019). Deconstructing and reconstructing cross-language transfer in bilingual reading development: An interactive framework. *Journal of Neurolinguistics*, 50, 149–161. <https://doi.org/10.1016/j.jneuroling.2018.01.003>
- Claussenius-Kalman, H., Hernandez, A.E., & Li, P. (2021). Expertise, ecosystem, and emergentism: Dynamic developmental bilingualism. *Brain and Language*, 222, 105013. <https://doi.org/10.1016/j.bandl.2021.105013>
- Cobo-Lewis, A.B., Pearson, B.Z., Eilers, R.E., & Umbel V.C. (2002). Effects of bilingualism and bilingual education on oral and written English Skills: A multifactor study of standardized test outcomes. In D.K. Oller & R.E. Eilers (Eds.), *Language and literacy in bilingual children* (pp. 64–97). Multilingual Matters. <https://doi.org/10.21832/9781853595721-005>
- Cobo-Lewis, A.B., Pearson, B.Z., Eilers, R.E., & Umbel V.C. (2002). Effects of bilingualism and bilingual education on oral and written Spanish skills: A multifactor study of standardized test outcomes. In D.K. Oller & R.E. Eilers (Eds.), *Language and literacy in bilingual children* (pp. 98–117). Multilingual Matters. <https://doi.org/10.21832/9781853595721-006>
- Costa, W.J., & Melo-Pfeifer, S. (2022). How is the bilingual development of Portuguese heritage children perceived by their parents? Results from an ethnographic case study of a non-formal learning setting in Germany. *International Journal of Bilingual Education and Bilingualism*, 25(3), 942–962. <https://doi.org/10.1080/13670050.2020.1731415>
- Cummins, J. (2021). *Rethinking the education of multilingual learners: A critical analysis of theoretical concepts*. Multilingual Matters. <https://doi.org/10.21832/9781800413597>
- D'Angelo, F. (2020). The additive effect of bilinguals metalinguistic awareness in additional language acquisition. In P.-A. Mather (Ed.), *Technology-enhanced learning and linguistic diversity: Strategies and approaches to teaching students in a 2nd or 3rd language (Emerald Studies in Higher Education, Innovation and Technology)* (pp. 13–24). Emerald Publishing Limited. <https://doi.org/10.1108/978-1-83982-128-820201002>
- D'Angelo, F., & Sorace, A. (2022). The additive effect of metalinguistic awareness in third or additional language acquisition. *International Journal of Bilingual Education and Bilingualism*, 25(10), 1–17. <https://doi.org/10.1080/13670050.2022.2064710>
- Day, R.R. (2015). Extending extensive reading. *Reading in a Foreign Language*, 27(2), 294–301.
- Del Maschio, N., Sulpizio, S., & Abutalebi, J. (2020). Thinking outside the box: The brain-bilingualism relationship in the light of early neurobiological variability. *Brain and Language*, 211, 104879. <https://doi.org/10.1016/j.bandl.2020.104879>
- Deluca, V., Rothman, J., & Pliatsikas, C. (2019). Linguistic immersion and structural effects on the bilingual brain: A longitudinal study. *Bilingualism: Language and Cognition*, 22(5), 1160–1175. <https://doi.org/10.1017/S1366728918000883>
- Denissova, G.V., Redkina, E.A., & Zaluzniak, A.A. (2019). Developing secondary language identity in the context of professional communication. *Psychology in Russia: State of the Art*, 12(1), 20–29. <https://doi.org/10.11621/pir.2019.0102>
- Dijkstra, T., & van Heuven, W.J.B. (2002). The architecture of the bilingual word recognition system: From identification to decision. *Bilingualism: Language and Cognition*, 5, 175–197. <https://doi.org/10.1017/S1366728902003012>
- Dijkstra, T., Wahl, A., Buytenhuijs, F., Van Halem, N., Al-Jibouri, Z., De Korte, M., & Rekké, S. (2019). Multilink: A computational model for bilingual word recognition and word translation. *Bilingualism: Language and Cognition*, 22(4), 657–679. <https://doi.org/10.1017/S1366728918000287>
- Elorza, I. (2013). Materials development for multilingual education. In C.A. Chapelle (Ed.), *The encyclopedia of applied linguistics* (pp. 3592–3597). Blackwell Publishing Ltd. <http://doi.org/10.1002/9781405198431.wbeal0748>
- Evans, L.M. (2020). Teaching for biliteracy development in linguistically diverse school environments of young children: What do all teachers need to know?. In B. Marshall, J. Manuel, D.L. Pasternak, & J. Rowsell (Eds.), *The Bloomsbury handbook of reading perspectives and practices* (pp. 91–105). <https://doi.org/10.5040/9781350137592.ch-07>

- Eviatar, Z., Taha, H., & Schwartz, M. (2018). Metalinguistic awareness and literacy among semitic-bilingual learners: A cross-language perspective. *Reading and Writing, 31*(8), 1869–1891. <https://doi.org/10.1007/s11145-018-9850-9>
- Fernandes, O.A. (2019). Language workout in bilingual mother-child interaction: A case study of heritage language practices in Russian-Swedish family talk. *Journal of Pragmatics, 140*, 88–99. <https://doi.org/10.1016/j.pragma.2018.11.021>
- Ferris, M.R., & Politzer, R.L. (1981). Effects of early and delayed second language acquisition: English composition skills of Spanish speaking junior high school students. *TESOL Quarterly, 15*, 263–274. <https://doi.org/10.2307/3586752>
- Fitzgerald, J. (2006). Multilingual writing in preschool through 12th grade: The last 15 years. In C.A. MacArthur, S. Graham, & J. Fitzgerald (Eds.), *Handbook of writing research* (pp. 337–354). Guilford Press.
- Forsyth, H. (2014). The influence of L2 transfer on L3 English written production in a bilingual German/Italian population: A study of syntactic errors. *Open Journal of Modern Linguistics, 4*, 429–456. <http://doi.org/10.4236/ojml.2014.43036>
- Francis, N. (1999). Bilingualism, writing, and metalinguistic awareness: Oral-literate interactions between L1 and L2. *Applied Psycholinguistics, 20*, 533–561. <https://doi.org/10.1017/S014271649900404X>
- Gale, K., McClay, D., Christie, M., & Harris, S. (1981). Academic achievement in the Milingimbi bilingual program. *TESOL Quarterly, 15*, 297–314. <https://doi.org/10.2307/3586755>
- Genesee, F. (2002). Rethinking bilingual acquisition. In J.-M. Dewaele, A. Housen & Li Wei (Eds.), *Bilingualism: Beyond basic principles: Festschrift in honour of Hugo Baetens Beardsmore* (pp. 158–182). Multilingual Matters.
- Goldenberg, C., Reese, L., & Rezaei A. (2011). Contexts for language and literacy development among dual-language learners. In A. Durgunoglu & C. Goldenberg (Eds.), *Language and literacy development in bilingual settings* (pp. 3–28). Guilford Press.
- Gort, M. (2019). Developing bilingualism and biliteracy in early and middle childhood. *Language Arts, 96*(4), 229–243.
- Gottardo, A., Gu, Y., Mueller, J., Baciu, I., & Pauchulo, A.L. (2011). Factors affecting the relative relationships between first- and second-language phonological awareness and second-language reading. In A. Durgunoglu & C. Goldenberg (Eds.), *Language and literacy development in bilingual settings* (pp. 141–167). The Guilford Press.
- Graham, S. (2019). Changing how writing is taught. *Review of Research in Education, 43*(1), 277–303. <https://doi.org/10.3102/0091732X18821125>
- Griva, E., & Chostelidou, D. (2014). Writing skills and strategies of bilingual immigrant students learning Greek as a second language and English as a foreign language. *International Journal on New Trends in Education and Their Implications: Reading & Writing, 5*(3). 176–188. <http://doi.org/4.10.4102/rw.v4i1.31>
- Grosjean, F. (1989). Neurolinguists, beware! The bilingual is not two monolinguals in one person. *Brain and Language, 36*, 3–15. [https://doi.org/10.1016/0093-934X\(89\)90048-5](https://doi.org/10.1016/0093-934X(89)90048-5)
- Grunow, A., Goldenberg, C., Reese, L., & Bryk, A. (2008). *Home and community resources for oral language development of Spanish-speaking students: A multilingual multi-level analysis*. Paper presented at the Annual Meeting of the American Educational Research Association.
- Hinesly, V. (2019). The effect of bilingualism on writing ability. *Young Scholars in Writing, 16*, 78–88.
- Hornberger, N. (2005). Opening and filling up implementation and ideological spaces in heritage language education. *Modern Language Journal, 89*(4), 605–609.
- Hristo, K., Milan, S., & Dagmar, K. (2017). Knowledge of Romani language grammar. *Psychology in Russia: State of the Art, 10*(4), 76–85. <https://doi.org/10.11621/pir.2017.0407>
- Ifont, H. A., & Tovar-García, E. D. (2018). Trilingualism, bilingualism and educational achievements: The case of Chuvash and Tatar in Rural Russia. *Educational Studies Moscow, 3*, 6–35. <https://doi.org/10.17323/1814-9545-2018-3-8-35>
- Jacquet, M., & French, R.M. (2002). The BIA++: Extending the BIA+ to a dynamical distributed connectionist framework. *Bilingualism, 5*(3), 202–205. <https://doi.org/10.1017/S1366728902223019>
- Kenner, C. (2005). *Becoming biliterate: Young children learning different writing systems*. Trentham Books.

- Khalaf, S., Santi, K.L., Kulesz, P.A., Bunta, F., & Francis, D.J. (2019). Bilingual phonological awareness: Construct validation in Grade 1 Spanish-speaking English learners. *New directions for child and adolescent development*, 166, 79–110. <https://doi.org/10.1002/cad.20303>
- Kiramba, L.K. (2017). Translanguaging in the writing of emergent multilinguals. *International Multilingual Research Journal*, 11(2), 115–130. <http://doi.org/10.1080/19313152.2016.1239457>
- Koda, K., & Zehler, A.M. (2007). Introduction: Conceptualizing reading universals, cross-linguistic variations, and second language literacy development. In K. Koda & A.M. Zehler (Eds.), *Learning to read to across languages: Cross-linguistic relationships in first- and second-language literacy development* (pp. 1–9). Routledge.
- Lay, N.D. (1982). Composing processes of adult ESL learners. *TESOL Quarterly*, 16, 406.
- Lee, Y.J. (2020). English language learners' bilingualism and biliteracy development in a Korean heritage school in the US. *The Journal of Educational Development*, 40(1), 17–34. <https://doi.org/10.34245/jed.40.1.17>
- Limberger, B.K., Azevedo, A.F.D., Ferstl, E.C., & Buchweitz, A. (2020). Phonemic awareness in an oral German-origin Brazilian language: A study of Hunsrückisch and German bilinguals. *Ilha do Deserto*, 72, 427–445. <https://doi.org/10.5007/2175-8026.2019v72n3p427>
- Ma, J., Wu, Y., Sun, T., Cai, L., Fan, X., & Li, X. (2020). Neural substrates of bilingual processing in a logographic writing system: An fMRI study in Chinese Cantonese-Mandarin bilinguals. *Brain Research*, 1738, 146794. <https://doi.org/10.1016/j.brainres.2020.146794>
- Marian, V., Bartolotti, J., van den Berg, A., & Hayakawa, S. (2021). Costs and benefits of native language similarity for non-native word learning. *Front. Psychol.*, 12, 651506. <http://doi.org/10.3389/fpsyg.2021.651506>
- Marian, V., & Hayakawa, S. (2021). Measuring bilingualism: The quest for a “bilingual quotient”. *Applied Psycholinguistics*, 42, 527–548. <https://doi.org/10.1017/S0142716420000533>
- Marian, V., & Kaushanskaya, M. (2004). Mapping written input onto orthographic representation: The case of bilinguals with partially overlapping orthographies. *Proceedings of the Annual Meeting of the Cognitive Science Society*, 26, 891–896.
- Medeiros, A.C., Santos, M.F., Varela, F.V., Rocha, T.A., Messias, B.L., & Azoni, C.A. (2020). Bilingualism in the development of phonological awareness skills: An integrative literature review. *Revista CEFAC*, 22(4), E0320. <https://doi.org/10.1590/1982-0216/20202240320>
- Midgett, E., & Philippakos, Z. (2018). Biliteracy, spelling, and writing: A case study. *The Language and Literacy Spectrum*, 26, 13–30.
- Morais, J. (1991). Phonological awareness: A bridge between language and literacy. In B.J. Fox & D.J. Sawyer (Eds.), *Phonological awareness in reading* (pp. 31–71). Springer. https://doi.org/10.1007/978-1-4612-3010-6_2
- Murphy, K.A., & Diehm, E.A. (2020). Collecting words: A clinical example of a morphology-focused orthographic intervention. *Language, Speech, and Hearing Services in Schools*, 51(3), 544–560. https://doi.org/10.1044/2020_LSHSS-19-00050
- Naeem, K., Filippi, R., Periche-Tomas, E., Papageorgiou, A., & Bright, P. (2018). The importance of socioeconomic status as a modulator of the bilingual advantage in cognitive ability. *Frontiers in Psychology*, 9, 1818. <https://doi.org/10.3389/fpsyg.2018.01818>
- Nakamura, J. (2018). Parents' use of discourse strategies in dual-lingual interactions with receptive bilingual children. In E. Babatouli (Ed.), *Crosslinguistic research in monolingual and bilingual speech* (pp. 181–200). Chania: ISMBS.
- O'Brien, B.A., Mohamed, M.B.H., Yussof, N.T., & Ng, S.C. (2019). The phonological awareness relation to early reading in English for three groups of simultaneous bilingual children. *Reading and Writing*, 32(4), 909–937. <https://doi.org/10.1007/s11145-018-9890-1>
- O'Brien, B.A., Yin, B., Li, L., Zhang, D., Chin, C.F., Zhao, S., & Vaish, V. (2014). *Bilingualism, literacy and reading achievement* (NIE Working Paper Series No. 4). Singapore: National Institute of Education.
- Oller, D.K., Pearson, B., & Cobo-Lewis, A. (2007). Profile effects in early bilingual language and literacy. *Applied Psycholinguistics*, 28, 191–230. <http://doi.org/10.1017/S0142716407070117>

- Pawlicka, P., Lipowska, M., & Jurek, P. (2018). Bilingual advantage? Literacy and phonological awareness in Polish-speaking early elementary school children learning English simultaneously. *Acta Neuro-psychologica*, 16(1), 27–46. <https://doi.org/10.5604/01.3001.0011.7046>
- Peng, P., & Kievit, R.A. (2020). The development of academic achievement and cognitive abilities: A bidirectional perspective. *Child Development Perspectives*, 14(1), 15–20. <https://doi.org/10.1111/cdep.12352>
- Pliatsikas, C., Meteyard, L., Veríssimo, J., DeLuca, V., Shattuck, K., & Ullman, M.T. (2020). The effect of bilingualism on brain development from early childhood to young adulthood. *Brain Structure and Function*, 225(7), 2131–2152. <https://doi.org/10.1007/s00429-020-02115-5>
- Ramírez-Esparza, N., & García-Sierra, A. (2014). The bilingual brain: language, culture and identity. In V. Benet-Martínez & Y. Y. Hong (Eds.), *The Oxford handbook of multicultural identity* (pp. 34–56). Oxford University Press.
- Ramos, S.L., Diego-Medrano, E., García, N., & Castillo, Y. (2022). An examination of family cohesion and self-esteem as mediators of bilingualism and reading achievement among second-generation immigrant students. *Journal of Latinos and Education*, 1–16. <https://doi.org/10.1080/15348431.2022.2030288>
- Reese, L., & Goldenberg, C. (2008). Parental involvement and the academic achievement of Hispanic students: Community literacy resources and home literacy practices among immigrant Latino/a families. *Marriage and Family Review*, 43(1/2), 109–139. <https://doi.org/10.1080/01494920802010272>
- Reese, L., Goldenberg, C., & Saunders, W. (2006). Variations in reading achievement among Spanish-speaking children in different language programs: Explanations and confounds. *The Elementary School Journal*, 106(4), 363–386. <https://doi.org/10.1086/503637>
- Reese, L., Linan Thompson, S., & Goldenberg, C. (2008). Variability in community characteristics and Spanish-speaking children's home language and literacy opportunities. *Journal of Multilingual and Multicultural Development*, 29(4), 271–290. <https://doi.org/10.2167/jmmd539.0>
- Relyea, J.E., & Amendun, S.J. (2020). English reading growth in Spanish-speaking bilingual students: Moderating effect of English proficiency on cross-linguistic influence. *Child Development*, 91(4), 1150–1165. <https://doi.org/10.1111/cdev.13288>
- Robinson, A.J., Blumenfeld, H.K., Potapova, I., & Pruitt-Lord, S.L. (2022). Language dominance predicts cognate effects and metalinguistic awareness in preschool bilinguals. *International Journal of Bilingual Education and Bilingualism*, 25(3), 922–941. <https://doi.org/10.1080/13670050.2020.1735990>
- Roehr-Brackin, K. (2018). *Metalinguistic awareness and second language acquisition*. Routledge. <https://doi.org/10.4324/9781315661001>
- Rubin, R., & Galván, C.V. (2005). Using writing to understand bilingual children's literacy development. *The Reading Teacher*, 58(8), 728–739. <https://doi.org/10.1598/RT.58.8.3>
- Sabti, A.A., Md Rashid, S., Nimehchisalem, V., & Darmi, R. (2019). The impact of writing anxiety, writing achievement motivation, and writing self-efficacy on writing performance: A correlational study of Iraqi tertiary EFL Learners. *SAGE open*, 9(4), 2158244019894289. <https://doi.org/10.1177/2158244019894289>
- Serna, I., & Hudelson, S. (1993). Becoming a writer of Spanish and English. *The Quarterly of the National Writing Project and The Center for the Study of Writing and Literacy*, 15(1), 1–5.
- Soltero-González, L., & Butvilofsky, S. (2016). The early Spanish and English writing development of simultaneous bilingual preschoolers. *Journal of Early Childhood Literacy*, 16(4), 473–497. <http://doi.org/16.10.1177/1468798415602050>
- Tabors, P.O., Pérez, M., & López, L.M. (2003). Dual language abilities of bilingual four-year-olds: Initial findings from the early childhood study of language and literacy development of Spanish-speaking children. *NABE Journal of Research and Practice*, 1(1), 70–91.
- Turdaliyevich, Z.M. (2022). Actual problems of bilingualism in a multi-ethnic environment. *International Journal of Culture and Modernity*, 13, 17–23.
- Uranova, V.V., Bliznyak, O.V., Mazhitova, M.V., & Isyakaeva, R.R. (2022). Osobennosti i printsipy ispolzovaniia bilingvalnogo obrazovaniia [Features and principles of using bilingualism in the

- educational environment]. *Russian Journal of Education and Psychology*, 13(1), 48–70. <https://doi.org/10.12731/2658-4034-2022-13-1-48-70>
- Usanova, I., & Schnoor, B. (2021). Biscrptuality as a bridge to biliteracy: The development of scriptual skills in reading and writing in Russian as a heritage language in Germany. *Journal of Home Language Research*, 4(1), 5, 1–14. <https://doi.org/10.16993/jhhr.40>
- Van Heuven, W.J.B., Dijkstra, T., & Grainger, J. (1998). Orthographic neighborhood effects in bilingual word recognition. *Journal of Memory and Language*, 39, 458–483. <https://doi.org/10.1006/jmla.1998.2584>
- Zinchenko, Y.P., Shaigerova, L.A., Dolgikh, A.G., & Savelieva, O.A. (2019). Metodologicheskie problemy issledovaniia vliianiia dvuiazychiia na kognitivnye protsessy i etnokulturnuiu identichnost' [Methodological issues of studying the impact of bilingualism on cognitions and ethnocultural identity]. *Vestnik Moskovskogo Universiteta. Seria 14. Psikhologiya* [Moscow University Psychology Bulletin, Series 14], 1, 174–194. <https://doi.org/10.11621/vsp.2019.01.174>

Original manuscript received June 20, 2022
Revised manuscript accepted January 20, 2023
First published online March 15, 2023

To cite this article: Oshchepkova, E.S., Kartushina, N.A., Razmakhnina, K.O. (2023). Bilingualism and Development of Literacy in Children: A Systematic Review. *Psychology in Russia: State of the Art*, 16(1), 3–25. DOI: 10.11621/pir.2023.0101

PSYCHOMETRICS

Psychometric Analysis of Two Brief Versions of the CERQ in the Argentinean Population: CERQ-18 and CERQ-27

Sergio Dominguez-Lara^a, Luciana Moretti^{b,c}, Pablo Ezequiel Flores-Kanter^{c,d*}, Roger Muñoz-Navarro^e, Leonardo A. Medrano^{b,c}

^a *Universidad de San Martín de Porres, Lima, Perú*

^b *Pontificia Universidad Católica Madre y Maestra, República Dominicana*

^c *Universidad Siglo 21, Argentina*

^d *Consejo Nacional de Investigaciones Científicas y Técnicas (CONICET), Argentina*

^e *Universitat de València, Spain*

*Corresponding author: ezequielk@gmail.com

Background. Emotion Regulation (ER) involves any explicit or implicit process that may alter the emotion felt, its duration and expression, and is a transdiagnostic factor of vulnerability involved in the etiology and maintenance of different emotional disorders. The Cognitive Emotion Regulation Questionnaire (CERQ) assesses nine cognitive strategies involved in ER and is a valuable tool. Its popularity and wide use led to the development of two abbreviated versions: a version with 18 items (two items per factor) and a 27-item version (three items per factor).

Objective. To analyze the psychometric properties of both versions in the Argentinean population.

Design. The research design was instrumental. The factor structure of the CERQ-18 and CERQ-27 as well as the reliability of the scores and the construct of each dimension were evaluated. In addition, we gathered validity evidence for its relationship with other variables by associating the CERQ scores with Difficulties in Emotion Regulation Scale (DERS) scores.

Results. The CERQ-18 presented more consistent evidence regarding its internal structure (adequate fit indices and factor loadings of moderate magnitude) and reliability. Given that the association of the two versions with the DERS is similar, we recommend that the 18-item version be used.

Conclusion. The CERQ-18 has quite similar psychometric properties to the CERQ-27 in the general population of Argentina and the findings contribute to an understanding of its internal structure.

Keywords: Emotion, validity, reliability, cognitive regulation, short scale

Introduction

Emotions are adaptive responses that favor our survival; however, when their intensity, frequency or duration occurs inappropriately or excessively, they can affect our psychosocial functioning and harm our quality of life. Emotion Regulation (ER) has a transdiagnostic nature, since it appears to be associated with a wide variety of mental disorders (Aldao et al., 2010; Duarte et al., 2015; Potthoff et al. 2016; Sakakibara & Kitahara, 2016).

ER involves any explicit or implicit process that may alter the emotion felt, its duration and/or expression (Denny et al., 2009). Among the factors involved in ER, cognitive processes play a prominent role (Garnefski & Kraaij, 2007). Indeed, attention to circumstances and the cognitive interpretation of events will determine the type of emotion experienced and the modulation of the emotional response (Jorrmann et al., 2009; Muñoz-Navarro et al., 2021).

Within the strategies of cognitive regulation of emotion, Garnefski and Kraaij (2007) have distinguished nine: 1) *Self-Blame*: thoughts in which the person blames him/herself for what was experienced; 2) *Blaming Others*: thoughts of blaming environmental factors or other people for the unpleasant experience; 3) *Rumination*: reiterative thoughts about negative emotions and ideas associated with a stressful event; 4) *Catastrophizing*: thoughts that magnify the negative; 5) *Putting into Perspective*: thoughts that minimize the seriousness of a situation by emphasizing the relativity of what happened when compared to other events; 6) *Positive Refocusing*: thoughts about pleasant topics instead of focusing on the stressful event; 7) *Positive Reappraisal*: providing an alternative interpretation by seeking a positive connotation or meaning in terms of personal growth resulting from an event; 8) *Acceptance*: the cognitive process by which the individual stops trying to change a negative situation or the emotions that it caused and just experiences them; and finally, 9) *Refocus on Planning*: thinking about how to handle a problematic situation or what steps to take to resolve it. These nine strategies are the basis for the Cognitive Emotion Regulation Questionnaire (CERQ, Garnefski & Kraaij, 2007).

According to Medrano et al. (2016) the nine CERQ factors can be explained from the contributions of evolutionary psychology: that human beings evolved from the adoption of behaviors that favored their survival. Thus, the tendency to think excessively and repeatedly about negative events, or to pay greater attention to negative stimuli, favored the survival of our ancestors. These primitive and archaic cognitive patterns would be activated whenever a person detected a threat. These cognitive processes, being evolutionarily ancient, would involve subcortical brain structures, which would lead them to be automatic, simple, rapid, motivationally intense, and largely out of voluntary control. Such is the case for Rumination and Catastrophizing, for example.

On the other hand, during recent evolutionary history the human species developed more elaborate cognitive patterns. These new functions are based on cortical structures, which are more complex, rational, and motivationally more diffuse, which is why they favor a slower, analytical and controlled response by the organism, in addition to consuming high attentional resources. Developing an alternative interpretation to a negative event, accepting the situation, giving it a positive meaning,

or planning concrete courses of action in the face of a negative event, requires more complex cognitive processes that demand conscious effort (Clare & Ortony, 2000; Dunbar & Shultz, 2007; Medrano et al., 2016), such as through Positive Reappraisal or Refocus on Planning. Based on this, we proposed to group cognitive strategies of emotion regulation into two broad categories: a) *automatic*, a primarily subcortical response (fast and difficult to regulate), and b) *elaborative*, a primarily cortical response (slow and analytical). Difficulties in emotion regulation are due to failures in the inhibition of automatic processes. For this reason, we hypothesized that automatic strategies (such as Catastrophizing or Rumination) are associated with greater difficulties in emotion regulation, while elaborative strategies (such as Positive Reappraisal or Refocus on Planning) present an inverse relationship with difficulties in emotion regulation.

The nine-factor model has been examined in several countries, such as Argentina, (Medrano et al., 2013), Iran (Abdi et al. 2012), Brazil (Schäfer et al. 2018), Portugal (Costa-Martins et al., 2016), France (d'Acremont & Van der Linden, 2007), Peru (Dominguez-Lara & Medrano, 2016), Spain (Domínguez-Sánchez et al., 2011), Turkey (Tuna & Bozo, 2012), the Netherlands (Garnefski et al., 2002), Arab countries (Megreya et al., 2016), Hungary (Miklósi et al., 2011), and China (Zhu et al., 2008). However, these studies focused on university samples, and studies with adults were less frequent (Ireland et al., 2017), senior adults (Carvajal et al., 2022) or clinical samples (McKinnon et al., 2020). The only studies with adult samples were found in the Netherlands (Garnefski & Kraaij, 2007), France (Jermann et al., 2006), and Romania (Perte & Miclea, 2011). In some studies, the oblique nine-factor structure achieved mainly poor statistical support with a confirmatory factor analysis (CFA), with poor factorial fit (Medrano et al., 2013; Tuna & Bozo, 2012; Zhu et al., 2008), and in some cases relatively low factor loadings were observed in some items (Dominguez-Lara & Medrano, 2016; Jermann et al., 2006; Medrano et al., 2013). This could be explained by the high interfactorial correlation between some factors (*e.g.*, Rumination and Catastrophizing), and in potential cross-loadings between items belonging to factors with moderate or high associations with each other, *i.e.*, in possible misspecifications in the model (Dominguez-Lara & Merino-Soto, 2018b; Saris et al., 2009). On the other hand, in those studies with an exploratory approach, it was observed that two dimensions merged (Perte & Miclea, 2011), or that items loaded on other factors, but not in the original one (Abdi et al., 2012), which is feasible, considering that exploratory factor analysis does not restrict item grouping to a given factor; it is possible that this reorganization reflects the true structure of the construct in the countries where the CERQ was analyzed.

The CERQ has proven to be a valuable tool in diverse professional applications. Its use at the clinical (Huh et al., 2017), organizational (Castellano et al., 2019) and educational (Vinter et al., 2020) levels allows the assessment of risk and protective factors in the response to emotionally conflictive or stressful situations (Garnefski & Kraaij, 2007). It is also a widely used instrument to assess the effectiveness of psychological interventions (Bernard & Walburg, 2020; Hamid et al., 2018).

Its popularity and wide use led to the development of two abridged versions. First, Garnefski and Kraaij (2006) developed a short version of the CERQ with 18

items, so that each of the original nine scales is assessed by two items. Despite this reduction in the number of items, the questionnaire maintains the factor structure and adequate psychometric properties (alpha coefficients between .68 and .81). However, a descriptive approach (corrected item-test correlation) was used to select the items of this version; to consolidate the internal structure, the Principal Components Analysis (PCA) with varimax rotation was used, and although the factor loadings were high, they may be inflated because the PCA includes specificity within the factor loadings. It is worth mentioning that the Little Jiffy — a combination of the PCA, varimax rotation, and Kaiser's rule — is disregarded (Lloret-Segura et al., 2014).

In that sense, a new brief version was developed with methods more consistent (Dominguez-Lara & Merino-Soto, 2015), and the items were selected considering empirical criteria (items with high factor loadings in preceding studies that had used a confirmatory approach) and theoretical criteria (items whose content was more compatible with the target strategy). The oblique nine-factor structure was supported by CFA, and later the findings were reaffirmed in a new study, where evidence was also obtained of its factorial equivalence with the 36-item version, as well as its association with depression and anxiety (Dominguez-Lara & Merino-Soto, 2018). The CERQ-18 performed well there, because it considers items with greater theoretical and empirical convergence with the construct, which is reflected in a more consistent version.

Considering that the psychometric literature discourages the measurement of latent variables with only two items, Holgado-Tello et al. (2018) developed an abbreviated version with 27 items, designed to assess the nine original dimensions of the model with three items per factor. The items were selected under an empirical criterion, by considering the items with the highest factor loadings after performing a CFA, although without specifying a minimum magnitude. From comparison of the two versions, Holgado-Tello et al. (2018) argue that the 27-item version is more appropriate for the specific assessment of the nine emotional regulation strategies and that the 18-item version is more appropriate in situations that require a global rating of the emotional regulation profile.

However, it is important to note that the results obtained suggest that both abbreviated versions have adequate psychometric properties and present similar test-criterion relationship evidence, so the superiority of one version over the other is debatable.

In light of the increasing use of brief instruments in the international literature, the present article aims to analyze the psychometric properties of the two brief versions of the CERQ in the Argentinean population, evaluating the factor structure of the CERQ-18 and CERQ-27 as well as the reliability of the scores and the construct of each dimension. In addition, we gathered validity evidence for its relationship with other variables by associating the CERQ scores with the Difficulties in Emotion Regulation Scale (DERS) scores, as was done in similar studies (Ireland et al., 2017). Direct and significant relationships were expected to be obtained between the DERS factors that assess difficulties in emotion regulation and the automatic strategies assessed by the CERQ (Catastrophizing, Rumination, Self-Blame, and Blaming

Others). On the other hand, inverse and significant relationships were expected to be obtained between DERS scores and the CERQ-assessed elaborative strategies (Positive Reappraisal, Positive Refocusing, Refocus on Planning, Acceptance, and Putting into Perspective).

Methods

Design

The research design was instrumental (Ato et al., 2013), examining the psychometric properties of two brief versions of CERQ.

Participants

The sample consisted of 800 Argentinean adults (60.1% women; 39.9% men; $M_{\text{age}} = 30.10$ years; $SD_{\text{age}} = 12.99$) selected from a non-probabilistic accidental sampling. Regarding the level of instruction: 0.4% had only completed primary school, 31.3% had incomplete secondary school, 14.4% had completed secondary school, 27.9% had incomplete tertiary or university studies, 21.0% had completed university studies, and 4.4% had postgraduate studies. Regarding participants' occupations, 58.63% were employees, 31% students, 2.75% housekeepers, 2% unemployed, 0.5% retirees, and 5.13% did not answer. Regarding geographic distribution, most of the sample comes from Córdoba (54%) and Buenos Aires (36%). The remaining 10% is distributed in other regions of the country.

Procedure

Questionnaire

The Cognitive Emotional Regulation Questionnaire (CERQ; Garnefski et al., 2002) consists of 36 items and has five polytomous response options ranging from almost never (1) to always (5). The items are grouped into nine strategies: *Rumination*, *Catastrophizing*, *Self-Blame*, *Blaming Others*, *Putting into Perspective*, *Acceptance*, *Positive Refocusing*, *Positive Reappraisal*, and *Refocus on Planning*. The Spanish version validated in Argentina (Medrano et al., 2013) was used. The 18-item version (Dominguez-Lara & Merino-Soto, 2018a) and the 27-item version (Holgado-Tello et al., 2018) were analyzed.

The Difficulties in Emotion Regulation Scale (DERS; Gratz & Roemer, 2004) is a 36-item self-report measure which has four dimensions: *Lack of Emotional Acceptance*, *Interference in Goal-Directed Behavior*, *Impulse Control Difficulties*, *Lack of Emotional Awareness*, *Lack of Emotional Clarity*, and *Limited Access to Emotion Regulation Strategies*. Participants are asked to indicate how often the items apply to themselves using a five-point Likert scale, with 1 = *almost never* (0–10%), 2 = *sometimes* (11%–35%), 3 = *about half the time* (36%–65%), 4 = *most of the time* (66%–90%), and 5 = *almost always* (91%–100%). Higher scores on each subscale indicate greater difficulties in emotion regulation. Preliminary evidence in Argentina (Medrano & Trógolo, 2014, 2016) suggests good psychometric properties of DERS, with adequate reliability for all subscales (alpha coefficients ranging from .70 to .87), except for lim-

ited access to the emotion regulation strategies subscale (Cronbach's alpha = .54) and concurrent validity with personality measures.

All participants included in the study received an informed consent statement highlighting the voluntary nature of participation, and the questionnaires were completed anonymously. Of the total number of participants, 54.3% responded to the online instruments through the Google Form platform and 45.7% responded in person, on paper. No statistically significant differences were observed between the two samples in terms of CERQ scores ($t_{[764]} = .76; p = .44$).

Data Analysis

To evaluate the internal structure of the CERQ-18 and CERQ-27, a confirmatory factor analysis (CFA) was performed, specifying the oblique nine-factor model, which has been extensively examined in previous studies. For this purpose, the WLSMV extraction method was used, taking as a basis the matrix of inter-item polychoric correlations.

The validity evidence in relation to its internal structure was evaluated considering three perspectives. The first was based on the magnitude of the most frequent fit indices used in the literature such as the CFI ($> .90$; McDonald & Ho, 2002), the RMSEA ($< .08$; Browne & Cudeck, 1993), and the WRMR (< 1 ; DiStefano et al., 2018).

The second perspective was based on analysis of potential misspecification associated with cross-loadings (Saris et al., 2009) with a specialized module (Dominguez-Lara & Merino-Soto, 2018b).

The third perspective was based on the empirical differentiation of the dimensions. This is a key aspect in the construction of multidimensional instruments, since in addition to the conceptual differentiation between the factors, there must also be empirical differentiation, and although there may be elements in common between them, each must retain its individuality so that the findings can be interpreted in terms of the desired factor. One aspect that can give evidence of such differentiation is the comparison of the AVE (average variance extracted) of a factor, with the squared interfactor correlation (ϕ^2 ; variance shared between factors), where the average variance extracted per factor ($> .50$; Fornell & Larcker, 1981) was expected. Mplus software version 7.0 (Muthén & Muthén, 1998–2015) was used.

To estimate construct reliability, the ω coefficient was used ($> .70$; Hunsley & Marsh, 2008). The reliability of the scores was estimated using the average inter-item correlation (r_{ii}) since the dimensions have few items (2, 3, and 4 items), expecting magnitudes greater than .40 (Clark & Watson, 1995). Finally, a comparison was made between the r_{ii} of each dimension among the three versions (CERQ, CERQ-27, and CERQ-18) with the q statistic expecting magnitudes smaller than .10 (Cohen, 1992) to conclude that the variation in reliability is not significant.

The equivalence between the brief versions, the CERQ-27 and CERQ-18, was analyzed separately. A procedure that corrects correlations between variables with items in common (Levy, 1967) was used, after which magnitudes above .70 are expected to conclude on the equivalence between versions (Putnam & Rothbart, 2006). Prior to this, skewness and kurtosis were assessed, expecting magnitudes between -2 and 2 (Gravetter & Wallnau, 2013).

Table 1*Parameters of the Oblique Nine-Factor Model — CERQ-18*

	E1	E2	E3	E4	E5	E6	E7	E8	E9
Item 9 ^a	.756								
Item 29	.769								
Item 17		.601							
Item 33		.874							
Item 2			.707						
Item 16			.850						
Item 15				.632					
Item 27				.800					
Item 10					.822				
Item 35					.836				
Item 11						.591			
Item 20						.883			
Item 23							.750		
Item 31							.915		
Item 13								.736	
Item 30								.661	
Item 14									.754
Item 24									.843
ω	.735	.713	.757	.681	.815	.714	.822	.657	.780
AVE	.581	.563	.611	.520	.687	.565	.700	.489	.640
E1	1	.001	.057	.051	.227	.031	.060	.016	.001
E2	.026	1	.024	.327	.192	.005	.010	.038	.001
E3	-.239	.154	1	.005	.058	.177	.213	.276	.039
E4	.225	.572	.068	1	.575	.000	.004	.067	.077
E5	.476	.438	-.240	.758	1	.016	.136	.009	.063
E6	-.177	.072	.421	-.016	-.127	1	.266	.158	.126
E7	-.245	.098	.462	-.066	-.369	.516	1	.567	.449
E8	-.127	.195	.525	.259	-.094	.397	.753	1	.311
E9	.032	-.030	.197	-.278	-.250	.355	.670	.558	1
M	4.139	6.054	7.834	6.365	4.980	7.282	7.451	8.311	6.385
SD	1.962	2.115	1.953	2.210	2.399	2.131	2.223	1.700	2.318
g_1	0.684	-0.074	-0.824	-0.052	0.495	-0.598	-0.704	-1.050	-0.172
g_2	-0.172	-0.581	0.276	-0.703	-0.725	-0.205	-0.242	0.911	-0.807

Finally, the bivariate correlations between the CERQ factors of each brief dimension, CERQ-27 and CERQ-18, and the DERS factors were analyzed, considering magnitudes above .20 as significant (Ferguson, 2009). IBM SPSS 20 software was used to perform these analyses. In the same way, the correlations between the DERS dimensions with the CERQ-27 and the DERS with the CERQ-18 were compared using the q statistic. The absolute value of the average correlation between CERQ and DERS was considered for comparisons.

Results

Regarding the analysis of validity evidence in relation to internal structure and reliability, all fit indices of the nine-factor model were adequate (CFI = .974; RMSEA = .046 [CI90% .037, .055]; WRMR = .768). The AVE was also higher than the shared variance between factors, except for the indicators associated with the relationship between Positive Reappraisal [E7] and Refocus on Planning [E8] (Table 1). However, 14 possible misspecifications associated with omitted cross-loadings were found. Regarding descriptive statistics, skewness and kurtosis reached adequate values.

The analysis carried out with the CERQ-27 indicates that the fit indices of the nine-factor model had less favorable results than with the CERQ-18. Two indicators were not adequate (CFI = .893; WRMR = 1.394), while only the RMSEA was adequate (RMSEA = .068 [CI 90% .063, .073]). Similar to the CERQ-18, the AVE was greater than the shared variance between factors, except for the indicators associated with the relationship between Positive Reappraisal [E7] and Refocus on Planning [E8] (Table 2). However, 56 possible misspecification errors associated with omitted cross-loadings were found. Regarding descriptive statistics, skewness and kurtosis reached adequate values.

Regarding the construct reliability of the CERQ-18 and CERQ-27, most of the dimensions present acceptable magnitudes, although in relation to the reliability of the scores, the magnitudes are acceptable ($r_{ii} > .40$; Table 3, Part 1). Regarding the comparison of the reliability of scores (r_{ii}) between versions, the CERQ-27 presents more favorable indicators than the CERQ only in Acceptance, while the CERQ-18 surpasses the CERQ in Blaming Others, Self-Blame, Acceptance, Catastrophizing, Putting into Perspective, and Positive Reappraisal. Regarding the comparison between the brief versions, CERQ-18 outperforms CERQ-27 in Acceptance, Catastrophizing, and Positive Reappraisal (Table 3, Part 2). Regarding the equivalence between long and short versions, the corrected association between CERQ and its short versions is marginal, and the correlation is equivalent between CERQ and its short versions ($q < .10$; Table 3, Part 3).

In relation to their association with other variables, the relationships among the nine CERQ factors, both the CERQ-27 and CERQ-18, and the DERS dimensions were analyzed, and verified with the CERQ factors called automatic and elaborative. The results show significant correlations in most cases ($> .20$; Table 5). Specifically, the strategies Self-Blame, Blaming Others, Rumination, and Catastrophizing show the strongest and most positive relationships with the different difficulties in emotion regulation. In general, an association between difficulties in emotion regulation and automatic cognitive strategies is corroborated.

Table 2*Parameters of the Oblique Nine-Factor Model — CERQ-27*

	E1	E2	E3	E4	E5	E6	E7	E8	E9
Item 9 ^a	.707								
Item 29	.814								
Item 36	.678								
Item 1		.652							
Item 17		.694							
Item 33		.753							
Item 2			.687						
Item 16			.786						
Item 32			.603						
Item 3				.504					
Item 15				.656					
Item 27				.786					
Item 10					.811				
Item 22					.549				
Item 35					.853				
Item 11						.646			
Item 20						.707			
Item 34						.721			
Item 12							.685		
Item 23							.732		
Item 31							.850		
Item 13								.778	
Item 19								.637	
Item 30								.704	
Item 4									.780
Item 14									.771
Item 24									.796
ω	.778	.743	.736	.690	.789	.734	.802	.750	.826
AVE	.541	.491	.485	.434	.562	.479	.576	.502	.612
E1	1	.000	.045	.040	.299	.005	.030	.004	.002
E2	.009	1	.052	.371	.212	.018	.002	.031	.007
E3	-.213	.229	1	.046	.040	.250	.303	.308	.082
E4	.201	.609	.215	1	.476	.025	.002	.169	.057

E5	.547	.460	-.199	.690	1	.002	.099	.009	.084
E6	-.074	.133	.500	.158	-.042	1	.372	.228	.218
E7	-.174	.046	.550	.048	-.315	.610	1	.696	.480
E8	-.060	.175	.555	.411	-.094	.477	.834	1	.250
E9	.041	-.082	.287	-.238	-.289	.467	.693	.500	1
M	6.249	8.906	11.479	10.119	6.906	11.004	11.599	12.234	9.746
SD	2.715	2.858	2.661	2.874	3.152	2.954	2.885	2.482	3.283
g ₁	0.679	-0.009	-0.701	-0.266	0.622	-0.589	-0.729	-1.010	-0.217
g ₂	0.150	-0.380	0.171	-0.341	-0.385	-0.166	-0.062	0.961	-0.739

Table 3
Three Versions of CERQ: Reliability and Equivalence between Versions

	Part 1		Part 2			Part 3		<i>q</i>						
	CERQ		CERQ-27		CERQ-18		Comparison of versions in terms of <i>r_{ii}</i>		CERQ/ CERQ-27	CERQ/ CERQ-18				
	<i>α</i>	<i>r_{ii}</i>	<i>α</i>	<i>r_{ii}</i>	<i>α</i>	<i>r_{ii}</i>	<i>q_{36,27}</i>		<i>q_{36,18}</i>	<i>q_{27,18}</i>	<i>r</i>	<i>r_{corrected}</i>	<i>r</i>	<i>r_{corrected}</i>
E1	.67	.34	.70	.44	.65	.48	.09	.12	.04	.92	.69	.86	.66	.02
E2	.69	.36	.68	.42	.63	.46	.05	.09	.04	.95	.69	.88	.66	.02
E3	.53	.22	.64	.38	.68	.52	.14	.26	.12	.91	.60	.81	.61	.00
E4	.68	.35	.64	.37	.62	.45	.02	.09	.07	.94	.66	.85	.63	.02
E5	.71	.38	.72	.46	.76	.62	.07	.19	.12	.95	.72	.87	.72	.00
E6	.66	.33	.66	.39	.61	.44	.06	.10	.04	.94	.66	.87	.63	.02
E7	.74	.42	.71	.45	.76	.61	.03	.15	.12	.97	.73	.90	.75	.01
E8	.66	.33	.67	.40	.55	.38	.07	.05	.01	.95	.67	.86	.61	.04
E9	.84	.57	.78	.54	.72	.56	.03	.01	.02	.98	.81	.94	.79	.01

Note: E1 = Blaming Others, E2 = Self-Blame; E3 = Acceptance; E4 = Rumination; E5 = Catastrophizing; E6 = Putting into Perspective; E7 = Positive Reappraisal; E8 = Refocus on Planning; E9 = Positive Refocusing; *r_{ii}*: average inter-item correlation; *q_{n,m}*: comparison of *r_{ii}* between *n*-items version and *m*-items version.

On the other hand, a strong relationship between elaborative strategies and difficulties in emotion regulation is not corroborated. The strategies of Acceptance, Putting into Perspective, Positive Reappraisal, Refocus on Planning, and Positive Refocusing are low ($r < .20$), and most of them do not reach significance. A significant relationship was only observed between the elaborative strategies with the lack of emotional awareness and lack of emotional clarity scales. Another aspect to highlight is that the relationship between automatic and elaborative strategies is weak. These results therefore suggest a certain independence; thus, the predominance of automatic strategies of emotion regulation may or may not coexist with elaborative strategies.

Table 4*Correlation between DERS and the Short Versions of CERQ*

	D1	D2	D3	D4	D5	D6	$ r_{\text{average}} $
E1 _{CERQ}	.326	.317	.336	.008	.208	.249	.241
E1 _{CERQ18}	.313	.300	.349	-.001	.146	.229	.223
E1 _{CERQ27}	.303	.290	.348	-.022	.164	.237	.220
E2 _{CERQ}	.390	.543	.295	.074	.109	.390	.300
E2 _{CERQ18}	.281	.223	.082	.077	.067	.223	.159
E2 _{CERQ27}	.339	.275	.124	.045	.063	.271	.186
E3 _{CERQ}	.159	.048	.031	.108	.129	.087	.094
E3 _{CERQ18}	.014	.001	-.073	.231	.150	-.036	.048
E3 _{CERQ27}	.054	.021	-.023	.219	.144	.018	.072
E4 _{CERQ}	.407	.274	.233	.137	.105	.317	.246
E4 _{CERQ18}	.269	.242	.200	.122	.091	.254	.196
E4 _{CERQ27}	.284	.230	.160	.241	.089	.248	.209
E5 _{CERQ}	.286	.239	.319	-.117	.050	.258	.173
E5 _{CERQ18}	.310	.338	.407	-.120	.067	.328	.222
E5 _{CERQ27}	.319	.284	.371	-.113	.040	.300	.200
E6 _{CERQ}	.222	.119	.097	.172	.137	.117	.144
E6 _{CERQ18}	.176	.121	.069	.157	.177	.124	.137
E6 _{CERQ27}	.202	.128	.063	.155	.157	.115	.137
E7 _{CERQ}	-.006	-.047	-.038	.294	.161	-.076	.048
E7 _{CERQ18}	-.032	-.050	-.040	.243	.107	-.082	.024
E7 _{CERQ27}	.009	-.028	-.019	.273	.151	-.057	.055
E8 _{CERQ}	.123	.099	-.040	.248	.176	.046	.109
E8 _{CERQ18}	.100	.000	-.064	.229	.184	-.004	.074
E8 _{CERQ27}	.109	.057	-.032	.263	.180	.017	.099
E9 _{CERQ}	.037	-.155	-.082	.027	.052	-.075	-.033
E9 _{CERQ18}	.072	-.119	-.029	-.007	.051	-.005	-.006
E9 _{CERQ27}	.057	-.135	-.055	.031	.054	-.063	-.019

Note: E1 = Blaming Others; E2 = Self-Blame; E3 = Acceptance; E4 = Rumination; E5 = Catastrophizing; E6 = Putting into Perspective; E7 = Positive Reappraisal; E8 = Refocus on Planning; E9 = Positive Refocusing; D1 = Lack of Emotional Acceptance; D2 = Interference in Goal-Directed Behavior; D3 = Impulse Control Difficulties; D4 = Lack of Emotional Awareness; D5 = Lack of Emotional Clarity; D6 = Limited Access to Emotion Regulation Strategies. ^a: in all cases, q coefficient compares CERQ-18 and CERQ-27.

On the other hand, the intensity of the correlation between cognitive strategies and emotion regulation difficulties is similar between both versions ($q < .10$; Table 4), but of weak magnitude.

Discussion

Understanding the ability to functionally regulate emotions is a key factor in understanding the psychological processes of health and disease (Cano-Vindel et al., 2016). Different psychological disorders, such as anxiety disorders and depression, are significantly related to emotion regulation styles. The CERQ is one of the most widely used instruments to assess cognitive factors involved in emotion regulation (Medrano et al., 2016); however, the length of the instrument may limit its use in professional practice. Due to the advantages of short questionnaires, two short versions of the CERQ have recently been developed with 18 and 27 items, with respectively two and three items per strategy. As Santisteban-Requena (2009) points out, the validity and reliability of a test may be affected as the length of the instrument is altered, so it would be necessary to evaluate empirically whether the short versions still adequately measure the construct.

The results obtained in the present study corroborate the adequate psychometric properties of the CERQ-18 in the Argentinean population, whereas in relation to the CERQ-27 the fit indices were not favorable and a high number of misspecifications were found that threaten the validity evidence. Indeed, the psychometric properties observed are acceptable and similar to those reported for the CERQ, but in some cases the reliability indicators evaluated with the average inter-item correlation was higher in the CERQ-18 with respect to the CERQ-27 and CERQ. In comparison to the 36-item version, in the case of the CERQ-18 the evidence of validity and reliability has been investigated by few studies. Consistent with this background (Dominguez-Lara & Merino-Soto, 2018a; Ireland, et al. 2017; Lee et al. 2020), evidence in favor of a correlated nine-factor structure is found in the present work.

Regarding the observed association between dimensions, the automatic factors of Catastrophizing, Rumination, and Self-Blame overlap considerably in both versions, as well as within the elaborative processes, the factors of Positive Reappraisal, Refocus on Planning, and Positive Refocusing. These results are consistent with some of the reported antecedent studies (e.g., Ireland et al., 2017), which go so far as to posit the existence of two underlying factors (Domínguez-Sánchez et al., 2013; Perte & Miclea, 2011). As suggested by Thompson (1997), such a conceptual and empirical approach may lead one to think about the existence of higher-order factors, suggesting the possibility of an alternative model that contemplates the presence of second-order factors. However, it was not possible to evaluate the fit of an alternative hierarchical model of two higher order factors, because they were under-identified. That is, the number of indicators with the 18-item version is not sufficient to examine the fit of such a model.

Regarding the evidence of validity with external sources, the relationships between the nine CERQ factors of the 18-item and 27-item versions and the DERS dimensions were analyzed. In the first instance, the hypothesized relationships between the automatic factors of the CERQ and the difficulties in emotion regulation were

verified. Specifically, it was observed that high scores on the factors of Self-Blame, Blaming Others, Rumination, and Catastrophizing were associated with impulse control difficulties, limited access to emotion regulation strategies, and interference in goal-directed behaviors. These results are consistent with those reported in previous research (Medrano et al., 2016; Muñoz-Navarro et al., 2021). The magnitude of the correlations is similar between the dimensions of the DERS and the two versions of the CERQ-18.

The relationship between elaborative cognitive strategies and difficulties in emotion regulation turned out to be more complex. The relationships were lower than expected ($r < .20$ and mostly non-significant). These findings could be attributed to either a) the short version of the CERQ does not adequately measure the elaborative factors, or b) the elaborative factors are not significantly associated with difficulties in emotion regulation. Considering previous research, the second option is more plausible. In fact, there is currently a debate about the role of elaborative processes and their role in the development of emotional disorders. Evidence suggests that it is automatic processes that are involved in the etiology and maintenance of emotional disorders, while elaborative processes would only play a role in modulating the automatic processes (Medrano et al., 2016). Thus, elaborative processes would not be directly related to difficulties in emotion regulation, but would mediate the impact of automatic processes.

It should also be noted that the relationship observed between automatic and elaborative strategies was weak. These results are consistent with previous research (Castellano et al., 2019; Dominguez-Lara & Medrano, 2016) and allow us to rule out the existence of an inverse relationship between the two types of processing. The use of elaborative strategies would not generate a decrease in automatic strategies, although it may possibly moderate their impact. It may happen that two people experience an automatic process (e.g., Catastrophizing or Rumination), but in one case this process is modulated by an elaborative strategy (e.g., reinterpretation) and in another case it is not. It would therefore be more useful to analyze profiles of cognitive regulation of emotions, rather than analyzing strategies independently and in isolation from each other. In fact, in a study by Trógolo and Medrano (2012), it was observed that when considering emotion regulation profiles with the DERS, greater predictive power was achieved than when considering each strategy in isolation.

A final aspect to note is the association between the elaborative strategies with the factors of lack of emotional awareness, and lack of emotional clarity. These results are consistent with previous research highlighting the role of emotional awareness as a preliminary step for the use of elaborative strategies (Price & Hooven, 2018). Thus, the lack of emotional clarity and awareness could be interpreted as a factor that hinders the use of elaborative strategies of emotional regulation.

Another important finding is that the shorter version, the CERQ-18, shows more consistent evidence regarding its internal structure (adequate fit indices and factor loadings of moderate magnitude) and reliability, in contrast to the CERQ-27, which presents weaker indicators. For that reason, and because the association of the two versions with the DERS is similar, it is advisable to use the 18-item version.

Conclusion

The CERQ-18 has psychometric properties quite similar to those of the CERQ-27 in the general population of Argentina and the findings contribute to understanding its internal structure. However, regarding its association with other variables, a scale that evaluates dysfunctional aspects (dysregulation) was considered as an external criterion of validity, so it would be convenient to also use external criteria focused on positive variables (*e.g.*, well-being) in order to have more information to decide on one version or another.

Having a brief instrument properly adapted to the Argentinean adult population makes it easier to develop studies aimed at evaluating the role of cognitive regulation of emotions in different contexts (educational, clinical, and organizational). In addition to its use in research, the present investigation provides a useful input for the identification of people with difficulties in emotion regulation and for the evaluation of interventions aimed at promoting more adequate styles of emotion regulation. The use of short versions is recommended in situations where, for reasons of time or sample disposition, the administration of the longer version is not possible.

Finally, it would be advisable to explore the patterns of association of the items with the factors to which they do not theoretically belong (cross-loadings) by means of exploratory structural equation modeling (ESEM; Asparouhov & Muthen, 2009). A hierarchical model could be analyzed under ESEM to provide further empirical support for the presence of second-order factors called automatic strategies and elaborative strategies.

Limitations

The sample is adequate, although it was not strictly representative of the general population of Argentina. It would therefore be useful to expand the sample with participants from other regions of the country.

Ethics Statement

This research study is associated with an approved investigative project and was carried out according to the principles of the Declaration of Helsinki (World Medical Association, 1964).

Author Contributions

SDL and LAM conceptualized the study and wrote a first draft of the manuscript. LM, PEFK, and RMN gave critical insight for revising the manuscript and made a substantial intellectual contribution to the work. SDL conducted data analysis. LAM, LM, and PEFK were responsible for the data acquisition. All authors have approved the final version of the manuscript and agreed to be accountable for all aspects of their work.

Conflict of Interest

The authors have no conflicts of interests to declare.

Acknowledgements

The authors thank the participants for their contributions to this research.

References

- Abdi, S., Taban, S., & Ghaemian, A. (2012). Cognitive emotion regulation questionnaire: Validity and reliability of the Persian translation of the CERQ (36-item). *Procedia, Social and Behavioral Sciences*, 32, 2–7. <https://doi.org/10.1016/j.sbspro.2012.01.001>
- Aldao, A., Nolen-Hoeksema, S., & Schweizer, S. (2010). Emotion-regulation strategies across psychopathology: A meta-analytic review. *Clinical Psychology Review*, 30(2), 217–237. <http://doi.org/10.1016/j.cpr.2009.11.004>
- American Psychological Association (APA). (2017). *Ethical principles of psychologists and code of conduct*. Washington, DC: Author.
- Asparouhov, T., & Muthen, B.O. (2009). Exploratory structural equation modeling. *Structural Equation Modeling*, 16(3), 397–438. <http://doi.org/10.1080/10705510903008204>
- Ato, M., López, J.J., & Benavente, A. (2013). Un sistema de clasificación de los diseños de investigación en psicología [A classification system for research designs in psychology]. *Anales de Psicología*, 29(3), 1038–1059. <https://doi.org/10.6018/analesps.29.3.178511>
- Bernard, L., & Walburg, V. (2020). Efficacy of a brief cognitive-emotional group intervention for patients with borderline personality disorder. *Psychologie Française*, 65(3), 185–196. <https://doi.org/10.1016/j.psfr.2019.11.001>
- Browne, M.W., & Cudeck, R. (1993). Alternative ways of assessing model fit. In K. A. Bollen & J. S. Long (Eds.), *Testing structural equation models* (pp. 445–455). Sage.
- Cano-Vindel, A., Muñoz-Navarro, R., Wood, C.M., Limonero, J.T., Medrano, L.A., Ruiz-Rodríguez, P., & Santolaya, F. (2016). Transdiagnostic cognitive behavioral therapy versus treatment as usual in adult patients with emotional disorders in the primary care setting (PsicAP Study): Protocol for a randomized controlled trial. *JMIR Research Protocols*, 5, e246. <http://doi.org/10.2196/resprot.6351>
- Carvajal, B.P., Molina-Martínez, M.A., Fernández-Fernández, V., Paniagua-Granados, T., Lasa-Aristu, A., & Luque-Reca, O. (2022). Psychometric properties of the Cognitive Emotion Regulation Questionnaire (CERQ) in Spanish older adults. *Aging & Mental Health*, 26(2), 413–422. <https://doi.org/10.1080/13607863.2020.1870207>
- Castellano, E., Muñoz Navarro, R., Toledo, M.S., Spontón, C., & Medrano, L.A. (2019). Cognitive processes of emotional regulation, burnout and work engagement. *Psicothema*, 31(1), 73–80. <https://doi.org/10.7334/psicothema2018.228>
- Clark, L.A., & Watson, D. (1995). Constructing validity: Basic issues in objective scale development. *Psychological Assessment*, 7(3), 309–319. <https://doi.org/10.1037/1040-3590.7.3.309>
- Clore, G.L., & Ortony, A. (2000). Cognition in emotion: Always, sometimes, or never. In R.D. Lane & L. Nadel (Eds.), *Cognitive neuroscience of emotion* (pp. 24–61). Oxford University Press.
- Cohen, J. (1992). A power primer. *Psychological Bulletin*, 112(1), 155–159. <https://doi.org/10.1037/0033-2909.112.1.155>
- Costa-Martins, E., Freire, M., & Ferreira-Santos, F. (2016). Examination of adaptive and maladaptive cognitive emotion regulation strategies as transdiagnostic processes: Associations with diverse psychological symptoms in college students. *Studia Psychologica*, 58(1), 59–74. <https://doi.org/10.21909/sp.2016.01.707>
- D'Acremont, M., & Van der Linden, M. (2007). How is impulsivity related to depression in adolescence? Evidence from a French validation of the Cognitive Emotion Regulation Questionnaire. *Journal of Adolescence*, 30(2), 271–282. <https://doi.org/10.1016/j.adolescence.2006.02.007>
- Denny, B.T., Silvers, J.A., & Ochsner, K.N. (2009). How we heal what we don't want to feel: The functional neural architecture of emotion regulation. In A.M. Kring & D.M. Sloan (Eds.), *Emotion regulation and psychopathology: A transdiagnostic approach to etiology and treatment* (pp. 59–87). Guilford Press.
- DiStefano, C., Liu, J., Jiang, N., & Shi, D. (2018). Examination of the weighted root mean square residual: Evidence for trustworthiness? *Structural Equation Modeling: A Multidisciplinary Journal*, 25(3), 453–466. <https://doi.org/10.1080/10705511.2017.1390394>

- Dominguez-Lara, S., & Medrano, L. (2016). Invarianza factorial del Cognitive Emotional Regulation Questionnaire (CERQ) en universitarios limeños y cordobeses [Factorial invariance of Cognitive Emotional Regulation Questionnaire (CERQ) in college students from Lima and Cordoba]. *Universitas Psychologica*, *15*(1), 89–98. <https://doi.org/10.11144/Javeriana.upsy15-1.ifce>
- Dominguez-Lara, S., & Merino-Soto, C. (2015). Una versión breve del Cognitive Emotional Regulation Questionnaire: Análisis estructural del CERQ-18 en estudiantes universitarios limeños [A short version of Cognitive Emotional Regulation Questionnaire: Structural analysis of CERQ-18 in university students from Lima]. *Revista Peruana de Psicología y Trabajo Social*, *4*(1), 25–36.
- Dominguez-Lara, S., & Merino-Soto, C. (2018a). Cognitive Emotional Regulation Questionnaire-18 en universitarios: Evidencias de validez convergente y discriminante [Cognitive Emotional Regulation Questionnaire-18 in college students: Evidence of convergent and discriminant validity]. *Revista Iberoamericana de Diagnóstico y Evaluación — e Avaliação Psicológica*, *47*(2), 171–184. <https://doi.org/10.21865/RIDEP47.2.12>
- Dominguez-Lara, S., & Merino-Soto, C. (2018b). Análisis de las malas especificaciones en modelos de ecuaciones estructurales [Testing misspecifications in structural equation modeling]. *Revista Argentina de Ciencias del Comportamiento*, *10*(2), 19–24. <https://doi.org/10.30882/1852.4206.v10.n2.19595>
- Domínguez-Sánchez, F., Lasa-Aristu, A., Amor, P., & Holgado-Tello, F. (2013). Psychometric properties of the Spanish version of the Cognitive Emotion Regulation Questionnaire. *Assessment*, *20*(2), 253–261. <https://doi.org/10.1177/10731911110397274>
- Duarte, A.C., Matos, A.P., & Marqués, C. (2015). Cognitive emotion regulation strategies and depressive symptoms: Gender's moderating effect. *Procedia-Social and Behavioral Sciences*, *165*, 275–283. <http://doi.org/10.1016/j.sbspro.2014.12.632>
- Dunbar, R.I., & Shultz, S. (2007). Understanding primate brain evolution. *Philosophical Transactions of the Royal Society B: Biological Sciences*, *362*(1480), 649–658. <https://doi.org/10.1098/rstb.2006.2001>
- Ferguson, C. (2009). An effect size primer: A guide for clinicians and researchers. *Professional Psychology: Research and Practice*, *40*(5), 532–538. <https://doi.org/10.1037/a0015808>
- Fornell, C., & Larcker, D.F. (1981). Evaluating structural equation models with unobservable variables and measurement error. *Journal of Marketing Research*, *18*(1), 39–50. <https://doi.org/10.1177/002224378101800104>
- Garnefski, N., & Kraaij, V. (2006). Cognitive Emotion Regulation Questionnaire—development of a short 18-item version (CERQ-short). *Personality and Individual Differences*, *41*(6), 1045–1053. <https://doi.org/10.1016/j.paid.2006.04.010>
- Garnefsky, N., & Kraaij, V. (2007). The Cognitive Emotion Regulation Questionnaire: Psychometric features and prospective relationships with depression and anxiety in adults. *European Journal of Psychological Assessment*, *23*(3), 141–149. <https://doi.org/10.1027/1015-5759.23.3.141>
- Garnefsky, N., Kraaij, V., & Spinhoven, P. (2002). *Manual for the use of Cognitive Emotion Regulation Questionnaire*. Leiderdorp, the Netherlands: DATEC.
- Gratz, K., & Roemer, L. (2004). Multidimensional assessment of emotion regulation and dysregulation: Development, factor structure, and initial validation of the Difficulties in Emotion Regulation Scale. *Journal of Psychopathology and Behavioral Assessment*, *26*(1), 41–54. <https://doi.org/10.1023/B:JOBA.0000007455.08539.94>
- Gravetter, F.J., & Wallnau, L.B. (2013). Introduction to statistics. In J. Hague, T. Matray, T. Williams, & L. Sarkisian (Eds.), *Statistics for the behavioral sciences* (pp. 3–36). Cengage Learning.
- Hamid, N., Boolaghi, Y., & Kiani Moghadam, A.S. (2018). The efficacy of acceptance and commitment based therapy (ACT) on depressive symptoms and cognitive emotion regulation strategies in depressive students. *International Journal of Psychology*, *12*(1), 5–29. <https://doi.org/10.24200/ijpb.2018.58144>
- Holgado-Tello, F.P., Amor, P.J., Lasa-Aristu, A., Domínguez-Sánchez, F.J., & Delgado, B. (2018). Two new brief versions of the Cognitive Emotion Regulation Questionnaire and its relationships with depression and anxiety. *Anales de psicología*, *34*(3), 458–464. <https://doi.org/10.6018/analesps.34.3.306531>
- Huh, H.J., Kim, K.H., Lee, H.K., & Chae, J.H. (2017). Attachment styles, grief responses, and the moderating role of coping strategies in parents bereaved by the Sewol ferry accident. *European Journal of Psychotraumatology*, *8*(6), 1424446. <https://doi.org/10.1080/20008198.2018.1424446>

- Hunsley, J., & Marsh, E.J. (2008). Developing criteria for evidence-based assessment: An introduction to assessments that work. In J. Hunsley & E. J. Marsh (Eds.), *A guide to assessments that work* (pp. 3–14). Oxford University Press.
- Ireland, M.J., Clough, B.A., & Day, J.J. (2017). The Cognitive Emotion Regulation Questionnaire: factorial, convergent, and criterion validity analyses of the full and short versions. *Personality and Individual Differences, 110*, 90–95. <https://doi.org/10.1016/j.paid.2017.01.035>
- Jermann, F., Van der Linden, M., d'Acromont, M., & Zermatten, A. (2006). Cognitive Emotion Regulation Questionnaire (CERQ): Confirmatory factor analysis and psychometric properties of the French translation. *European Journal of Psychological Assessment, 22*(2), 126–131. <https://doi.org/10.1027/1015-5759.22.2.126>
- Lee, D.J., Thompson-Hollands, J., Strage, M.F., Marx, B.P., Unger, W., Beck, J.G., & Sloan, D.M. (2020). Latent factor structure and construct validity of the Cognitive Emotion Regulation Questionnaire–Short Form among two PTSD samples. *Assessment, 27*(3), 423–431. <https://doi.org/10.1177/1073191118791301>
- Levy, P. (1967). The correction for spurious correlation in the evaluation of short-form tests. *Journal of Clinical Psychology, 23*(1), 84–86. [https://doi.org/10.1002/1097-4679\(196701\)23:1<84::aid-jclp2270230123>3.0.co;2-2](https://doi.org/10.1002/1097-4679(196701)23:1<84::aid-jclp2270230123>3.0.co;2-2)
- Lloret-Segura, S., Ferreres-Traver, A., Hernández-Baeza, A., & Tomás-Marco, I. (2014). El análisis factorial exploratorio de los ítems: una guía práctica, revisada y actualizada [Exploratory Item Factor Analysis: A practical guide revised and updated]. *Anales de psicología, 30*(3), 1151–1169. <http://doi.org/10.6018/analesps.30.3.199361>
- McDonald, R.P., & Ho, M.-H.R. (2002). Principles and practice in reporting structural equation analyses. *Psychological Methods, 7*(1), 64–82. <https://doi.org/10.1037/1082-989X.7.1.64>
- McKinnon, A., Kuyken, W., Hayes, R., Werner-Seidler, A., Watson, P., Dalgleish, T., & Schweizer, S. (2020). The psychometric properties of the Cognitive Emotion Regulation Questionnaire (CERQ) in a clinical sample of adults with recurrent depression. *Journal of Affective Disorders, 276*, 212–219. <https://doi.org/10.1016/j.jad.2020.06.061>
- Medrano, L., & Trógolo, M. (2014). Validación de la Escala de Dificultades en la Regulación Emocional en la población universitaria de Córdoba, Argentina [Validation of the Difficulties in Emotion Regulation Scale in the university population of Cordoba, Argentina]. *Universitas Psychologica, 13*(4), 1345–1356. <https://doi.org/10.11144/Javeriana.UPSY13-4.vedr>
- Medrano, L.A., & Trógolo, M. (2016). Construct validity of the Difficulties in Emotion Regulation Scale: Further evidence using confirmatory factor analytic approach. *Abnormal and Behavioural Psychology, 2*(2), 1345–1356. <https://doi.org/10.4172/2472-0496.1000117>
- Medrano, L.A., Muñoz-Navarro, R., & Cano-Vindel, A. (2016). Procesos cognitivos y regulación emocional: Aportes desde una aproximación psicoevolucionista [Cognitive processes and emotion regulation: contributions from a psycho-evolutionary approach]. *Ansiedad y Estrés, 22*(2–3), 47–54. <https://doi.org/10.1016/j.anyes.2016.11.001>
- Medrano, L., Moretti, L., Ortiz, A., & Pereno, G. (2013). Validación del Cuestionario de Regulación Emocional Cognitiva en universitarios de Córdoba, Argentina [Validation of the Cognitive Emotion Regulation Questionnaire in university students of Córdoba, Argentina]. *Psykhé, 22*(1), 83–96. <https://doi.org/10.7764/psykhe.22.1.473>
- Megreya, A.M., Latzman R.D., Al-Attayah A.A., & Alrashidi M. (2016). The robustness of the nine-factor structure of the Cognitive Emotion Regulation Questionnaire across four Arabic-speaking Middle Eastern countries. *Journal of Cross-Cultural Psychology, 47*(6), 875–890. <https://doi.org/10.1177/0022022116644785>
- Muñoz-Navarro, R., Medrano, L.A., González-Blanch, C., Carpallo-González, M., Olave, L., Iruarrizaga, I., Ruiz-Rodríguez, P., Moriana, J.A., & Cano-Vindel, A. (2021). Validity of brief scales for assessing transdiagnostic cognitive emotion regulation strategies in primary care patients with emotional disorders. *European Journal of Psychological Assessment, 37*(2), 86–94. <https://doi.org/10.1027/1015-5759/a000584>
- Muthén, L.K., & Muthén, B.O. (1998–2015). *Mplus user's guide* (7th ed.). Muthén & Muthén.

- Perte, A., & Miclea, M. (2011). The standardization of the Cognitive Emotion Regulation Questionnaire (CERQ) on Romanian population. *Cognition, Brain, Behavior. An Interdisciplinary Journal*, 15(1), 111–130.
- Potthoff, S., Garnefski, N., Miklósi, M., Ubbiali, A., Domínguez-Sánchez, F.J., Martins, E.C., Wirthöft, M., & Kraaij, V. (2016). Cognitive emotion regulation and psychopathology across cultures: A comparison between six European countries. *Personality and Individual Differences*, 98, 218–224. <https://doi.org/10.1016/j.paid.2016.04.022>
- Price, C.J., & Hooven, C. (2018). Interoceptive awareness skills for emotion regulation: Theory and approach of mindful awareness in body-oriented therapy (MABT). *Frontiers in Psychology*, 9, 798. <https://doi.org/10.3389/fpsyg.2018.00798>
- Putnam, S.P., & Rothbart, M.K. (2006). Development of short and very short forms of the Children's Behavior Questionnaire. *Journal of Personality Assessment*, 87(1), 102–112. https://doi.org/10.1207/s15327752jpa8701_09
- Sakakibara, R., & Kitahara, M. (2016). The relationship between Cognitive Emotion Regulation Questionnaire (CERQ) and depression, anxiety: Meta-analysis. *The Japanese Journal of Psychology*, 87(2), 179–185. <https://doi.org/10.4992/jjpsy.87.15302>
- Santisteban-Requena, C. (2009). *Principios de psicometría* [Basics of psychometrics]. Síntesis.
- Saris, W.E., Satorra, A., & van der Veld, W.M. (2009). Testing structural equation modeling or detection of misspecifications? *Structural Equation Modeling*, 16(4), 561–582. <https://doi.org/10.1080/10705510903203433>
- Schäfer, J.L., Filho, B.R.C., de Moura, T.C., Tavares, V.C., Arteché, A.X., & Kristensen, C.H. (2018). Psychometric properties of the Brazilian version of the Cognitive Emotion Regulation Questionnaire. *Trends in Psychiatry and Psychotherapy*, 40(2), 160–169. <https://doi.org/10.1590/2237-6089-2017-0074>
- Thompson, B. (1997). The importance of structure coefficients in structural equation modeling confirmatory factor analysis. *Educational and Psychological Measurement*, 57(1), 5–19. <https://doi.org/10.1177/0013164497057001001>
- Trógolo, M., & Medrano, L.A. (2012). Personality traits, difficulties in emotion regulation and academic satisfaction in a sample of Argentine college students. *International Journal of Psychological Research*, 5(2), 30–39. <https://doi.org/10.21500/20112084.734>
- Tuna, E., & Bozo, O. (2012). The Cognitive Emotion Regulation Questionnaire: Factor structure and psychometric properties of the Turkish version. *Journal of Psychopathology and Behavioral Assessment*, 34(4), 564–570. <https://doi.org/10.1007/s10862-012-9303-8>
- Vinter, K., Aus, K., & Arro, G. (2020). Adolescent girls' and boys' academic burnout and its associations with cognitive emotion regulation strategies. *Educational Psychology*, 41(8), 1–18. <https://doi.org/10.1080/01443410.2020.1855631>
- World Medical Association. (1964). *Declaration of Helsinki*. Helsinki: AMM. Retrieved from http://www.conamed.gob.mx/prof_salud/pdf/helsinki.pdf
- Zhu, X., Auerbach, R., Yao, S., Abela, J., Xiao, J., & Tong, X. (2008). Psychometric properties of the Cognitive Emotion Regulation Questionnaire: Chinese version. *Cognition and Emotion*, 22(2), 288–307. <https://doi.org/10.1080/02699930701369035>

Original manuscript received June 16, 2022

Revised manuscript accepted February 14, 2023

First published online March 15, 2023

To cite this article: Dominguez-Lara, S., Moretti, L., Flores-Kanter, P.E., Muñoz-Navarro, R., Medrano, L.A. (2023). Psychometric Analysis of Two Brief Versions of the CERQ in the Argentinean Population: CERQ-18 and CERQ-27. *Psychology in Russia: State of the Art*, 16(1), 26–43. DOI: 10.11621/pir.2023.0102

SOCIAL PSYCHOLOGY

Social Axioms and Individual Values as Predictors of COVID-19 Fear among University Students from Countries with Different Government Strategies for Managing the Pandemic

Nadezhda V. Murashcenkova^{a*}

^a HSE University, Moscow, Russia

*Corresponding author. E-mail: ncel@yandex.ru

Background. Effective prevention of psychological trauma by fear of COVID-19 requires the study of the relationships between the psychological and contextual factors that can influence the level of this fear. The social axioms, individual values, and government strategies for managing the pandemic have not yet been studied as a system of psychological and contextual factors contributing to COVID-19 fear.

Objective. The aim of this study was to assess the level of COVID-19 fear and the characteristics of the relationships between the social axioms, individual values, and fear of COVID-19 among university students from countries with different government strategies for managing the pandemic.

Design. University students from countries with different government strategies for managing the pandemic (208 Belarusians, 200 Kazakhstanis, and 250 Russians ages 18 to 25) participated in an anonymous online survey. The respondents filled in questionnaires that assessed their manifestations of COVID-19 fear (COVID-19 Fear Scale: FCV-19S) as the dependent variable; the “Social Axiom Questionnaire” (QSA-31) and the “Portrait Value Questionnaire” (ESS-21) measured the social axioms and individual values as the independent variables.

Results. Fear of COVID-19 reached a higher level among the students from the countries with the weakest (Belarus) and the strongest (Kazakhstan) restrictive measures during the pandemic. Dysfunctional fear of COVID-19 was manifest among those Belarusian students who attached the greatest importance to self-enhancement values and the fate control axiom, and the least importance to the social complexity axiom, as well as among those Russian students for whom the religiosity social axiom was significant and the social complexity axiom was not. For Kazakhstani students, social axioms and values were not predictors of dysfunctional fear of COVID-19.

Keywords:

Social axioms, individual values, fear of COVID-19, government strategies for managing the pandemic, students

Conclusion. The greatest contribution of social axioms and individual values to the experience of COVID-19 fear among the students was observed under conditions where the actions of the authorities were incompatible with the existing pandemic risks (in Belarus), as well as under conditions where a variable assessment of threat level was possible (in Russia).

Introduction

The COVID-19 pandemic has given scientists the important task of determining the factors that can preserve the psychological well-being of populations in different countries under the threat of the disease (Bavel et al., 2020). One of the ways of solving this task is to identify the contextual and psychological factors that increase fear of COVID-19 among students, who are a high-risk group for the adverse effects of the pandemic (Deng et al., 2021). Students faced significant lifestyle changes during the pandemic (Aristovnik et al., 2020). These included adaptation to online learning (Pokhrel & Chhetri, 2021), changes in academic habits, social exclusion, and limited contact with peers (Aristovnik et al., 2020). A meta-analysis of 89 contemporary studies (Deng et al., 2021) confirmed an increase in anxiety and depression symptoms and sleep disorders among university students in different countries during the pandemic. Another meta-analysis focused on assessing the aggregate mean of coronavirus infection fear among college students of different countries (Wang et al., 2022). The study confirmed the importance of developing and implementing preventive mental health programs for college students during and after the pandemic.

The COVID-19 pandemic was a very strong stressor associated with the risk of causing the occurrence and long-term presence of different mental health disorders in the population (Cohen-Louck & Levy, 2021). Fear of COVID-19 was the core psychological novelty brought by the pandemic (Mertens et al., 2021), which increased the risk of psychological trauma for the population. Fear is a person's adaptive response to danger. Fear of COVID-19 may lead people to behave cautiously during the pandemic (Harper et al., 2021; Pakpour & Griffiths, 2020). However, a prolonged experience and/or high level of COVID-19 fear can have an extremely damaging effect (Asmundson & Taylor, 2020; Ornell et al., 2020; Ren et al., 2020; Satici et al., 2020; Schimmenti et al., 2020). At the individual level, it can manifest itself in the development of anxiety-related disorders, depression, suicidal thoughts, and post-traumatic stress (Asmundson & Taylor, 2020; Ornell et al., 2020; Satici et al., 2020). At the social level, panic and xenophobia may spread (Ren et al., 2020; Schimmenti et al., 2020). Fear of COVID-19 is particularly dangerous because it can increase the damage from the disease itself (Ren et al., 2020).

Fear of COVID-19 is a complex multidimensional construct that includes various components (Mertens et al., 2021) and is measured by different psychological questionnaires (Ahorsu et al., 2022; Arpacı et al., 2020; Mertens et al., 2020; Schimmenti et al., 2020; Taylor et al., 2020). In our study, we researched fear about one's own health and fear of getting infected with the coronavirus, namely the psychophysiological and psycho-emotional manifestations of COVID-19 fear. The assessment

of psychophysiological and psycho-emotional manifestations of fear is important for differentiating functional and dysfunctional fears of COVID-19 (Harper, 2021; Solymosi et al., 2021). The markers of dysfunctional fear are primarily its psychophysiological manifestations (Hyde et al., 2019). Therefore, the ability to predict traumatization by fear of COVID-19 implies that we first analyze the level of its psychophysiological manifestations and the predictors of these manifestations.

We understand fear as an emotion based on experience and cognitive processing (Barrett, 2017) related to the assessment and interpretation of events (Lazarus, 1996). These assessments and interpretations depend on both external context and internal psychological factors (Lazarus & Folkman, 1984). The strategies governments adopted for managing the pandemic situation may have contributed to the development of COVID-19 fear, acting as significant external contextual factors (Al-Mahadin, 2020; Odintsova et al., 2021). In a COVID-19 threat situation, different countries responded in different ways and implemented different pandemic management strategies: these included the state-level strategy of pandemic denial, as in Belarus (Karáth, 2020; Odintsova et al., 2021; Shpakou et al., 2021); the introduction of a self-isolation regime, as in Russia (Reshetnikov et al., 2020); and the declaration of a state of emergency, as in Kazakhstan (Abramov et al., 2022). Meanwhile, the key parameter differentiating government strategies of managing the pandemic, which were significant in terms of their impact on the psychological state of citizens, was the degree of severity of the restrictive measures imposed on the population (Odintsova et al., 2021; Hale et al., 2020).

Internal factors can include social axioms and individual values, which act as filters of threat perception (Leung & Bond, 2009; Schwartz, 2015). Psychological research shows that social axioms and values are powerful psychological factors that influence people's attitudes and behaviors in various spheres of activity (Leung & Bond, 2009; Schwartz, 2015), including disease risk assessment and the formation of different fears (Boehnke & Schwartz, 1997; Frink et al., 2004; Hui et al., 2007; Li et al., 2021; Schwartz et al., 2000; Tong et al., 2020). However, as far as we know, no published works have assessed the contribution of social axioms and individual values to fear of COVID-19 among students from countries with different government strategies for managing the pandemic.

Social axioms and individual values represent two distinct but interrelated types of psychological constructs (Leung et al., 2007). Both have the function of choosing and regulating people's attitudes and behavior in different situations (Leung & Bond, 2009; Schwartz, 2015). People's beliefs about the social world complement their motives for achieving various goals (Bond et al., 2004a). In this regard, the comprehensive study of social axioms and individual values can contribute to a better understanding of the mechanisms of people's attitudes and behavior in complex situations requiring problem solving and adaptation (Bond et al., 2004a).

According to the theory developed by Michael Bond and Kwok Leung, social axioms are generalized beliefs about oneself, the social and physical environment, or the spiritual world, and are in the form of an assertion about the relationship between two entities or concepts (Leung et al., 2002). These beliefs are universal and determine the behavior and attitudes of people in different situations (Leung & Bond,

2009). Social axioms' functions relate to people's ability to adapt and survive (Bond et al., 2004b).

There are studies on the functioning of social axioms during the COVID-19 pandemic. For example, a Chinese sample (18-85 years old) showed a positive association of the fate control axiom with a high perception of the risk of coronavirus disease (Li et al., 2021). On a sample of Russians between 17 and 80 years of age, a positive correlation was found between a belief in conspiracy theories about COVID-19's origin and the social cynicism axiom (Nestik et al., 2020). In another study on a Chinese sample (18 to 87 years old), a negative link between taking precautions in relation to COVID-19 and the social cynicism axiom was found (Tong et al., 2020). In this sample, the positive link between the reward for application axiom and taking precautions in relation to COVID-19 was also discovered (Tong et al., 2020). Therefore, the existing research confirms the significant role of social axioms in shaping people's attitudes toward the pandemic and people's behavior during this period.

Basic individual values, according to the theory by Shalom Schwartz, are motivational trans-situational goals that are the directing principles in people's lives and influence their ideas, attitudes, and behavior (Schwartz, 1992; Schwartz et al., 2012). Schwartz considers values as beliefs inseparably related to affect (2015). Considering the theoretical aspects of the relationship between values and worries, Schwartz and colleagues (2000) underline that the same situation may provoke very different interpretations from people with varying value priorities. Values priorities impact worries, focusing individual attention and perception toward situations that threaten these values. A person's perception of a threat to the realization of values important to them tends to elicit negative affective reactions (Schwartz, 2015). In the motivational approach to emotions, there is a similar idea, according to which fear arises when a person is prevented from achieving his/her desired goals (Lazarus, 1991). At the same time, Schwartz (2014) emphasizes that people for whom conservation values are more important than the values of openness to change can be physiologically more sensitive to negative and/or exciting environmental features. Thus, we can conclude that the link between values and fear can be mediated by two parameters, *i.e.*, the significance of the values for the person and their content.

According to the basic provisions of Schwartz's theory, conservation and self-enhancement values are generally related to avoiding or controlling anxiety (Schwartz, 2015). The values of self-enhancement have significant links with micro worries (fears for oneself and loved ones) (Boehnke et al., 1998; Schwartz et al., 2000). There is scientific evidence (Daniel et al., 2022) that concerns about infection by the COVID-19 virus are related to the diminished importance of the openness to change values and the increasing importance of conservation values (data from the Australian adult sample). Among Brazilian respondents (mean age 38), researchers have found a link between worries about coronavirus infection and the security value (Fischer et al., 2021).

However, under the unique conditions of the pandemic, we cannot predict exactly how individual values and expressions of COVID-19 fear can be linked with different social contexts, namely, in countries with different strategies of managing the pandemic. At the same time, the study of the relationship between social axioms,

values, and real fear of COVID-19 (rather than abstract fear) in a real pandemic (rather than in hypothetical conditions) in different social contexts is of particular interest. The forced closure of international borders during the pandemic created the conditions for the study of various psychological phenomena in physically isolated environments with different contextual factors. Under these circumstances, the relationships of social axioms, values, and fear of COVID-19 can have their own specificity. This can be a consequence of the specific interaction between personal characteristics and social context (Fischer et al., 2021).

Consequently, the objective of this study was to assess the level of COVID-19 fear and the characteristics of the relationships between the social axioms, individual values, and fear of COVID-19 among university students from countries with different government strategies of managing the pandemic. Due to the novelty and particularity of the problem, and the absence of previous research, our analysis is somewhat speculative (Swedberg, 2021) and based on empirical scientific results (data-driven approach) (Jack et al., 2018). We have not proposed special research hypotheses, but rather two research questions:

1. Do university students from countries with different government strategies of managing the pandemic differ in their psychophysiological and psycho-emotional manifestations of COVID-19 fear?
2. Do university students from countries with different government strategies of managing the pandemic differ in the relationship between COVID-19 fear and their social axioms and individual values?

Methods

Participants

We tried to minimize the possible influence of sociocultural factors on the characteristics of relationships of dependent and independent variables in the study. Therefore, we included Russian-speaking students who are citizens of post-Soviet countries into the sample. The participants in the study were university students of ages 18-25 from Belarus, Kazakhstan, and Russia. After the dissolution of the USSR, Belarus, Kazakhstan, and Russia have maintained close socio-economic and cultural ties. They are all member states of the Common Economic Space and the Customs Union. Both in Belarus and Kazakhstan, free legal use of the Russian language is governed by the state. In Belarus, the Russian language has the status of a second state language, while in Kazakhstan it has the status of an official language and is used by the authorities and local governments on an equal footing with the State language (Kazakh).

We used a cross-sectional correlation design in the study. All respondents were Russian-speaking citizens and residents of their countries. The online link to the questionnaire was distributed to potential respondents by teachers and students from universities in the three countries. The total number of completed online questionnaires was 1,723. We removed the questionnaires that were partially filled out and did not match the sample parameters. After this, the basic sample included 987 students (208 Belarusians, 200 Kazakhstanis, and 579 Russians). For this study,

which involved multi-group analysis, we reduced the sample of Russians to 250. Using stratified selection, the sample of Russian students was balanced by basic socio-demographic parameters with the samples of Belarusian and Kazakhstani students. Accordingly, the sample of this study included 208 Belarusians, 200 Kazakhstanis, and 250 Russians.

Table 1 presents the age and gender composition of the three samples, as well as the cities of residence and the personal experience of the respondents with the coronavirus.

Table 1
Sample Composition

Citizenship (place of residence)	N	Age		Males (%)	Personal experience with the coronavirus (I was sick myself) (%)
		M	SD		
Belarusians (Minsk, Grodno, Vitebsk)	208	19.8	1.9	25.0	28.8
Kazakhstanis (Nur-Sultan, Pavlodar, Ust-Kamenogorsk)	200	20.5	1.9	26.0	11.0
Russians (Moscow, Saint Petersburg, Khabarovsk, Omsk, Penza, Smolensk)	250	20.0	1.5	25.2	29.2

Students majoring in humanities, engineering, and economics participated in the study (according to the samples: 87.5%, 8.2%, and 4.3% in Belarus; 68.5%, 22.5%, and 9.0% in Kazakhstan; and 70.4%, 8.0%, and 21.6% in Russia, respectively). Almost half of the respondents in each country answered that they did not belong to any religious denomination (45.6% Russians, 41.5% Kazakhstanis, and 49.0% Belarusians). Orthodox Christianity was the dominant religion in the Russian (46.4%) and Belarusian (40.9%) samples, while in the Kazakhstani sample it was Islam (39.5%).

Procedure

Empirical data were collected from January 2021 to April 2021 in an anonymous survey on the anketolog.ru platform. Before completing the questionnaire, the respondents gave informed consent to participate in the study. The respondents volunteered to participate in the study and did not receive a reward.

According to the weekly epidemiological reports of the World Health Organization, during the time of data collection, the number of people infected and deceased from the coronavirus increased in all three countries (Weekly epidemiological update — 27 January 2021; Weekly epidemiological update on COVID-19 — 20 April 2021). In the pre-data-collection phase (2020), Belarus demonstrated a state-level strategy of pandemic denial (Kar ath, 2020; Odintsova et al., 2021; Shpakou et al., 2021). Kazakhstan was the first among the three states to introduce restrictive mea-

asures and the only country to introduce a state of emergency (Abramov et al., 2022). A self-isolation regime was declared in Russia (Reshetnikov et al., 2020). At the time of the online survey, the three countries differed in their COVID-19 Stringency Index, which was extracted from the Oxford COVID-19 Government Response Tracker (Hale et al., 2020). At the time of the start of the online survey (January 2021), Belarus had the lowest level of restrictive measures (43), the highest level of restrictive measures was in Kazakhstan (69), and the intermediate level was observed in Russia (50). At the end of the empirical data collection (April 2021), the restrictive measures indicator remained the highest in Kazakhstan (63). In Belarus (42) and Russia (42), these parameters were equal.

Measures

The online survey included validated and reliable psychological questionnaires. The dependent variable in our study was the fear of COVID-19, and the independent variables were social axioms and individual values. Additionally, the study collected the socio-demographic parameters of the respondents, such as gender, age, and economic status. Moreover, we assessed their level of religiosity and their personal experience with the pandemic. In the online questionnaire, the respondents also added information on citizenship, ethnic identity, place of residence, and the university major. We controlled the variables, such as gender, age, economic status, level of religiosity, and experience with the coronavirus that might have had a correlation with fear of COVID-19, social axioms, and individual values in our study.

Social Axioms

To assess social axioms, we used the “Social Axiom Questionnaire” (QSA-31), developed and tested by A.N. Tatarko and N.M. Lebedeva (Tatarko & Lebedeva, 2020). This is a shortened version of the full Russian-language version of Bond’s and Leung’s “Social axioms” questionnaire (Tatarko & Lebedeva, 2011). The five-factor structure of the social axioms model has been confirmed in this questionnaire. It has high reliability and coherence. According to the questionnaire keys (Tatarko & Lebedeva, 2020), data processing calculated the mean values for five social axioms: social cynicism; fate control; religiosity; reward for application; and social complexity. Cronbach’s alphas for these scales were: Belarusian students, $\alpha = 0.66/0.78/0.91/0.81/0.69$; Kazakhstani students, $\alpha = 0.72/0.75/0.93/0.82/0.66$; and Russian students, $\alpha = 0.64/0.73/0.91/0.80/0.58$, respectively.

Individual Values

To assess individual values, we used the abridged version of the “Portrait Value Questionnaire” by Schwartz (ESS-21), developed for the European Social Survey (Schwartz et al., 2001). The questionnaire comprises 21 items and measures 10 basic values and four higher order values. In this study, the variables were higher order values. According to the recommendations by Schwartz (Schwartz, 2003), and in accordance with the objective and method (MGSEM) of the study, we calculated mean

values for four higher order values. Cronbach's alphas for the Conservation values/Openness to change values scales were: Belarusians, $\alpha = 0.63/0.67$; Kazakhstanis, $\alpha = 0.58/0.68$; and Russians, $\alpha = 0.68/0.69$. Cronbach's alphas for the Self-Enhancement/Self-Transcendence values scales were: Belarusians, $\alpha = 0.71/0.66$; Kazakhstanis, $\alpha = 0.67/0.58$; and Russians, $\alpha = 0.74/0.70$.

Fear of COVID-19

To measure the expression of COVID-19 fear, we used the COVID-19 Fear Scale (FCV-19S) developed by a group of scientists from the United Kingdom, Hong Kong, Iran, and Sweden (Ahorsu et al., 2022). The Russian-language version of the questionnaire was tested in a Russian-language sample in Russia and Belarus (Reznik et al., 2021). The questionnaire includes seven items. The respondents indicated their level of agreement with the items using a 5-point scale: 1 = "strongly disagree," 2 = "disagree," 3 = "neither agree nor disagree," 4 = "agree," and 5 = "strongly agree." The sum of the items was then calculated. The higher the score, the greater was the fear of COVID-19.

Some academic papers compare the one-factor (Al-Shannaq et al., 2021; Mailliez et al., 2021) and the two-factor (Chen et al., 2022; Tzur Bitan et al., 2020) structure of this questionnaire. The advantage of using the two-factor structure of the Fear of COVID-19 Scale is the possibility of differentiating the psychophysiological and psycho-emotional manifestations of COVID-19 fear in the assessment (Chen et al., 2022; Tzur Bitan et al., 2020). In our study, we use a two-factor structure. The first factor includes third, sixth, and seventh items of the COVID-19 Fear Scale and shows the psychophysiological manifestations of COVID-19 fear (e.g., "My hands become clammy when I think about coronavirus-19"). The second factor contains the first, second, fourth, and fifth items of this questionnaire and shows the psycho-emotional manifestations of this fear (e.g., "I am most afraid of coronavirus-19").

In our Multigroup Structural Equation Modeling (MGSEM) study, we modulated the dependent variables (the psychophysiological and the psycho-emotional manifestations of COVID-19 fear) as two latent factors represented by three and four measured variables. In addition, we analyzed the reliability and coherence of these two scales. Cronbach's alphas for scales of the psychophysiological manifestations of COVID-19 fear and psycho-emotional manifestations of COVID-19 fear were: Belarusians, $\alpha = 0.88/0.80$; Kazakhstanis, $\alpha = 0.80/0.79$; and Russians, $\alpha = 0.80/0.75$, respectively.

Statistical Analysis

For statistical analysis we used SPSS Statistics version 23 and AMOS version 23. We calculated the psychometric measures of the scales (Cronbach's alpha) and descriptive statistics for the dependent and independent variables. Additionally, we calculated the significance of the mean value differences (ANOVA with a post-hoc test) for each basic variable among the three samples. For testing the assumptions of Multi-Group Structural Equation Modeling (MGSEM), AMOS version 23 was used.

Results

In the first step of data processing, we calculated the internal consistency of the scales (Cronbach's alpha). All scales had sufficient internal consistency in each of the three samples (Nasledov, 2013). In the second step, we calculated the descriptive statistics and the significance of mean value differences for each basic variable across the three samples. *Table 2* shows the descriptive statistics and the significance of mean value differences (ANOVA with post-hoc test) of basic variables in the three samples.

Table 2

Means, Standard Deviations, Differences (Belarusians, Kazakhstanis, and Russians)

Variables	Belarusians	Kazakhstanis	Russians
	M(SD)	M(SD)	M(SD)
1. Reward for application	4.12(0.62)k ^{***}	4.44(0.55)r ^{***} ,b ^{***}	4.20(0.57)k ^{***}
2. Social complexity	4.01(0.34)	4.02(0.38)	4.04(0.33)
3. Social cynicism	2.94(0.61)	2.94(0.69)	2.93(0.61)
4. Religiosity	2.67(0.96)k [*]	2.92(1.09)b [*]	2.72(0.98)
5. Fate control	2.34(0.81)k ^{**}	2.56(0.76)b ^{**}	2.41(0.73)
6. Self-Transcendence values	4.55(0.77)	4.74(0.69)	4.62(0.78)
7. Openness to change values	4.44(0.72)	4.54(0.74)	4.50(0.73)
8. Self-Enhancement values	4.22(0.87)	4.17(0.92) r [*]	4.29(0.94) k [*]
9. Conservation values	3.84(0.78)	3.96(0.79)	3.80(0.81)
10. Psychophysiological manifestations of COVID-19 fear	4.70(2.54)r ^{***}	4.89(2.47)r ^{***}	3.98(1.67)k ^{***} ,b ^{***}
11. Psycho-emotional manifestations of COVID-19 fear	10.35(4.11) r ^{**}	10.36(4.21)r ^{**}	9.22(3.76)k ^{**} , b ^{**}

Note. *b* = The statistically significant difference with Belarusians. *k* = The statistically significant difference with Kazakhstanis. *r* = The statistically significant difference with Russians.
p* < .05; *p* < .01; ****p* < .001.

We did not find any statistically significant differences in social axioms and individual values between Belarusian and Russian youth. However, Kazakhstani students showed more commitment to the reward for application axiom than their Belarusian and Russian counterparts. In addition, Kazakhstani students showed more commitment to social axioms, such as religiosity and fate control than their Belarusian colleagues. Moreover, there were some differences in individual values among the students from Kazakhstan and Russia. Kazakhstani students were more predisposed to self-enhancement values than Russian students. Despite the differences identified, the students from all three countries had the same hierarchical structure (according to means) of social axioms (in ascending order: fate control, religiosity, social cynicism, social complexity, reward for application) and of higher order values (in ascending order: conservation, self-enhancement, openness to change, and self-transcendence values).

We did not find any statistically significant differences in the manifestations of COVID-19 fear between Belarusian and Kazakhstani youth. However, Russian students showed a lower level of psychophysiological and psycho-emotional manifestations of COVID-19 fear than the Belarusian and Kazakhstani students.

Figure 1 presents a multi-group model of the relationship (unconstrained) of social axioms with the psychophysiological and the psycho-emotional manifestations of COVID-19 fear across the three countries. The sequence of coefficients is the following: Belarusians/Kazakhstanis/Russians.

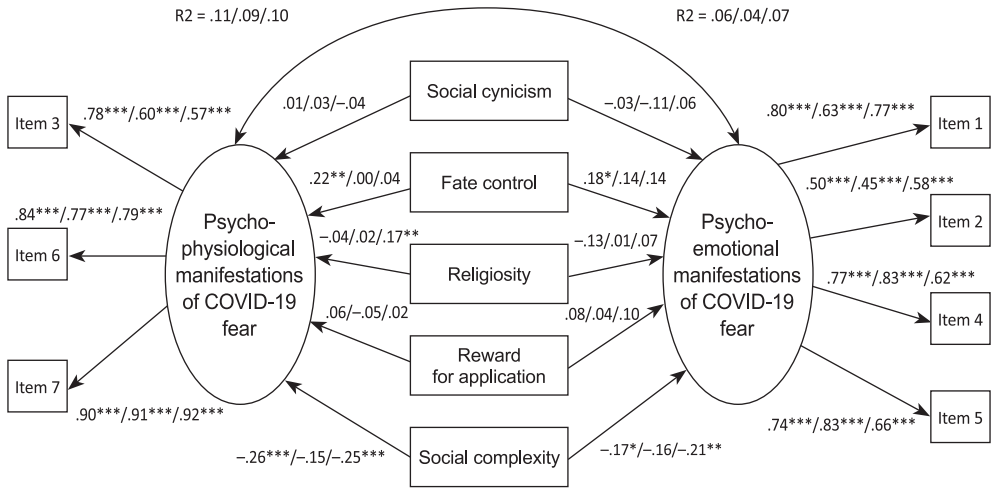

Note. * $p < .05$; ** $p < .01$; *** $p < .001$.

Figure 1. Standardized Coefficients (Unconstrained) for the Multi-Group Model (Controlling for Age, Gender, Economic Status, Level of Religiosity, and Personal Experience with COVID-19) of the Relationship Between Social Axioms and Fear of COVID-19 Across Students of Three Countries (Belarusians/Kazakhstanis/Russians)

According to the goodness-of-fit indices, this model fits the empirical data (see Table 3). There are configural, metric, and scalar invariance.

Table 3

Invariance for the Model of the Relationship Between Social Axioms and Fear of COVID-19 Across Students of Belarus, Kazakhstan, and Russia

Model	CFI	ΔCFI	RMSEA	PCLOSE	AIC	χ ²	df	p
Unconstrained	0.955		0.035	1.000	517.881	205.881	114	< 0.001
Measurement weights	0.951	0.004	0.035	1.000	516.389	224.389	124	< 0.001
Measurement intercepts	0.958	0.007	0.031	1.000	488.389	224.389	138	< 0.001
Structural weights	0.959	0.004	0.029	1.000	467.484	243.484	158	< 0.001

Note. CFI = comparative fit index; RMSEA = root mean square error of approximation; PCLOSE = p of Close Fit. AIC = Akaike information criterion; χ² = chi-square; df = degrees of freedom; p = p-value.

We discovered no statistically significant relationships between manifestations of COVID-19 fear and social axioms among Kazakhstani youth. Among Belarusian and Russian youth, social axioms contributed more to the explanation of psychophysiological manifestations of COVID-19 fear than psycho-emotional manifestations. Among Belarusian youth, the students who were committed to the axiom of fate control and did not share the belief in the social complexity of the world had larger psychophysiological manifestations of COVID-19 fear. The commitment to the axiom of fate control and low belief in social complexity were also predictors of psycho-emotional manifestations of COVID-19 fear among Belarusian students. However, the links of these predictors to psycho-emotional manifestations were weaker than with psychophysiological manifestations of this fear. The weak commitment to the social complexity axiom, combined with a strong belief in the beneficial influence of religion on society, were predictors of the psychophysiological manifestations of COVID-19 fear among Russian youth. Moreover, Russian students who did not believe in the complexity of the social world also had high psycho-emotional manifestations of this fear.

Figure 2 visually represents the multi-group model of the relationship of values with the psychophysiological and psycho-emotional manifestations of COVID-19 fear across students of the three countries. The sequence of coefficients is the following: Belarusians/Kazakhstanis/Russians.

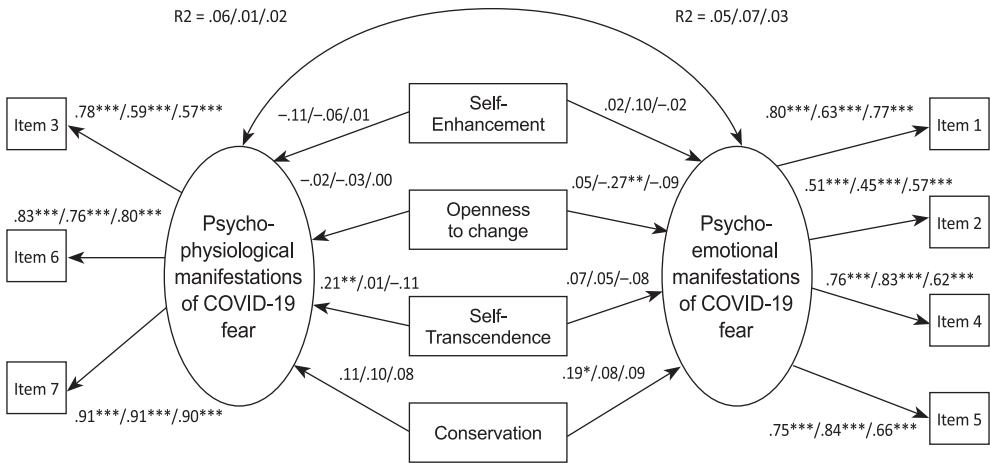

Note. *p < .05; **p < .01; ***p < .001.

Figure 2. Standardized Coefficients (Unconstrained) for the Multi-Group Model (Controlling for Age, Gender, Economic Status, Level of Religiosity, and Personal Experience with COVID-19) of the Relationship Between Individual Values and Fear of COVID-19 Across Students of Three Countries (Belarusians/Kazakhstanis/Russians)

As in the previous model (see Table 3), according to the goodness-of-fit indices, this model fit the empirical data (see Table 4). There are configural, metric, and scalar invariances.

Table 4

Invariance for the Model of the Relationship Between Individual Values and Fear of COVID-19 Across Students of Three Countries

Model	CFI	Δ CFI	RMSEA	PCLOSE	AIC	χ^2	df	p
Unconstrained	0.958		0.036	0.998	448.610	196.610	105	< 0.001
Measurement weights	0.954	0.004	0.037	0.999	447.522	215.522	115	< 0.001
Measurement intercepts	0.960	0.006	0.032	1.000	419.522	215.522	129	< 0.001
Structural weights	0.954	0.004	0.032	1.000	415.977	243.977	145	< 0.001

Note. CFI = comparative fit index; RMSEA = root mean square error of approximation; PCLOSE = *p* of Close Fit. AIC = Akaike information criterion; χ^2 = chi-square; df = degrees of freedom; *p* = *p*-value.

We discovered only one statistically significant relationship between the values and the psychophysiological manifestations of COVID-19 fear, and two statistically significant relationships between the values and the psycho-emotional manifestations of this fear. In the first case, there was a positive link between the psychophysiological manifestations of COVID-19 fear and self-enhancement values among Belarusian youth. In the second case, there was a negative relationship between the psycho-emotional manifestations and openness to change values among Kazakhstani youth, and the positive relationship between the psycho-emotional manifestations and conservation values among Belarusian youth.

Individual values ($R^2_{be}=.06$, $R^2_{kz}=.01$, $R^2_{ru}=.02$) contributed less to the explanation of psychophysiological manifestations of COVID-19 fear than social axioms ($R^2_{be}=.11$, $R^2_{kz}=.09$, $R^2_{ru}=.10$) in all three samples, respectively. In addition, they ($R^2_{be}=.05$, $R^2_{ru}=.03$) explained a smaller percentage of the variance of psycho-emotional manifestations of this fear than social axioms did ($R^2_{be}=.06$, $R^2_{ru}=.07$) in the Belarusian and Russian samples. Individual values ($R^2_{kz}=.07$) explained a larger percentage of the variance of psycho-emotional manifestations of this fear than social axioms ($R^2_{kz}=.04$) in the Kazakhstani sample only.

Discussion

We found that fear of COVID-19 (both its psychophysiological and psycho-emotional manifestations) was more distinct among the students from the countries with the weakest (Belarus) and strongest (Kazakhstan) restrictive measures during the pandemic, which is consistent with existing studies (Al-Mahadin, 2020; Odintsova et al., 2021). In this regard, we can conclude that the risk of psychological trauma to youth caused by fear of COVID-19 was higher in Belarus and Kazakhstan than in Russia, *i.e.*, in states, which have implemented polar-opposite strategies of managing the pandemic. In Belarus, the strategy was the denial of the pandemic, and in Kazakhstan, it was the establishment of a state of emergency.

In Belarus, the mechanism of increased fear was most likely related to cognitive dissonance. It arose when information transmitted by the authorities did not cohere

with information received by the people from other sources (Internet, social networks, acquaintances, etc.). This could contribute to increasing tension and anxiety about the insufficiency of measures, the level of protection and control of the situation by the State, and could provoke the actualization of fear. At the same time, it is worth noting that youth are the most Internet-oriented part of the population, with access to a wide variety of sources of information that they actively use. In the Kazakhstani case, we are rather dealing with a mechanism of escalating fear, as the measures applied by the State are associated with a high level of existing risks and threats (Han et al., 2021).

We discovered no common relationships between social axioms, individual values, and COVID-19 fear among Russian-speaking students in the post-Soviet countries with different strategies of managing the pandemic and the degree of restrictive measures severity. This leads us to the conclusion that government policies of containing the pandemic can mediate the links between fundamental psychological constructs and fear of coronavirus infection. Social axioms had the most influence on dysfunctional fear in students of Belarus and Russia, *i.e.*, countries with weak and moderate restrictive measures during the pandemic. Among Kazakhstani students, we did not discover any relations between social axioms and fear of COVID-19, although the level of dysfunctional fear among Kazakhstanis, similarly to Belarusians, was significantly higher than among Russians. It is likely that the state of emergency and state-imposed measures (as a contextual factor) in Kazakhstan had a stronger impact on the growth of fear than social axioms. Perhaps, when the high threat of the pandemic is recognized at the state level, as was the case in Kazakhstan, and does not imply other interpretations of the situation, the diversity of psychological characteristics of the people with dysfunctional fear is broader. Therefore, we could not detect clear psychological profiles of the links between dysfunctional fear of coronavirus infection and specific social axioms. For Belarusian and Russian students, on the contrary, we identified such profiles and can explain them based on the results of already existing studies.

Among Belarusians, fear of coronavirus infection (both its psychophysiological and psycho-emotional manifestations) was positively associated with the fate control axiom and negatively associated with the social complexity axiom. An earlier study showed that social axioms can be protective mechanisms that defend people from fears (Hui et al., 2007). The social complexity axiom is a cognitive resource that is linked to coping strategies (Bond et al., 2004a), and is particularly relevant when adapting to new and unusual conditions such as the pandemic (Hui & Hui, 2009). In turn, the fate control axiom is connected with distancing from trying to solve problems and a distorted perception (wishful thinking) (Bond et al., 2004a). As the results of our research demonstrate, the belief in high control by fate, combined with a low belief in the complexity of the social world, can lead to a fatalistic assessment of the present, provoking an increase in fear of COVID-19 among Belarusian students. Let us recall that these links are manifested among the students of Belarus, a country that denied the danger of the pandemic at the state level and applied the weakest restrictive measures of the three countries that we studied.

Among Russian students, psycho-emotional manifestations of COVID-19 fear were negatively related with the social complexity axiom. At the same time, psycho-physiological manifestations of COVID-19 fear among Russian youth had both a negative link with the social complexity axiom and a positive relationship with the religiosity axiom. That is, the dysfunctional fear of coronavirus infection (psycho-physiological markers) had a higher level among those Russian students who were convinced of the beneficial influence of religion on society and underestimated the complexity of social peace and human behavior.

Let us consider a possible explanation for this. Young people with a positive attitude towards religion (and most likely with a religious world view) may view the pandemic not as a situation that occurs objectively due to the confluence of different circumstances, but as punishment, retribution, and chastisement from above. These perceptions can lead to increased anxiety and fear, as such ideas of the source of the threat are also linked to perceptions of its uncontrollability. At the same time, the connections found may indirectly indicate that Russian respondents with high levels of COVID-19 fear prefer a religious way of knowing and explaining the world to a scientific way of knowing, *i.e.*, faith versus verification and proof of assumptions. In this case, we can talk about the resource potential of the social complexity axiom, which is related to the scientific way of understanding the world and is associated with active coping in the prevention of psychological traumatization by fear among Russian and Belarusian students.

The positive link of the religiosity axiom with the fear of COVID-19, discovered only among Russian students, suggests that this relationship may be due to socio-cultural factors. In this case, however, we tend to explain the link on the basis of the different government strategies for managing the pandemic in the three countries. The choice of this explanatory approach, which is based on the analysis of the social context rather than the sociocultural characteristics of the respondents, was prompted by the following analysis.

In the Kazakhstani sample, we found no relationship between the religiosity axiom and fear of COVID-19, despite the fact that this axiom (as well as the level of religiosity in general) was most strongly expressed in the Kazakhstani sample. Using the contextual approach, we explain the positive link between the religiosity axiom and fear of COVID-19 among Russian youth as manifesting an intolerance towards uncertainty and its relationship with attitude towards religion (Ulybina & Baklanova, 2019). Russia's chosen strategy of moderating restrictive measures during the pandemic (compared to Kazakhstan, where the authorities introduced a state of emergency), increased the level of uncertainty, allowing the population to have different interpretations of the level of the current COVID-19 threat. In turn, research results confirm that loss of a sense of certainty can lead to increased religiosity (Laurin et al., 2008; Wichman, 2010). Therefore, probably the highest level of COVID-19 fear in the Russian sample was demonstrated by those respondents who had a low level of tolerance of uncertainty, and who referred to religion as a valuable system of understandable explanatory principles and meanings, which replaces the need for independent analysis of the situation.

It is known that religion provides people a worldview with elaborate information-processing schemes, offers normative practices of everyday life, and provides clear rules of behavior. In this way, religion helps people cope with uncertainty, creates a sense of order, and helps to reduce anxiety (Shaw et al., 2005). Moreover, scientific evidence has shown that religiosity and intolerance of uncertainty have common physiological grounds, and religious belief reduces brain reactions associated with anxiety (Inzlicht et al., 2009). At the same time, we do not rule out the possibility of the reverse influence, *i.e.*, of fear as an independent variable being a predictor of axioms as dependent variables. Perhaps, among Russian students with a high level of dysfunctional fear and underestimation of the social world complexity, the recognition of the beneficial influence of religion on society was a consequence of the search for additional resources to control anxiety and cope with the pandemic.

In turn, the strategy for managing the pandemic in Kazakhstan, associated with severe restrictive measures, did not allow for variations in interpretations of the existing threat level. This is probably why the link between the religiosity axiom and the COVID-19 fear was not discovered in the Kazakhstani sample. In Belarus, we saw a different situation. The state-level strategy of pandemic denial, combined with the objective threat of COVID-19 in Belarus, could promote perceptions of the situation as particularly threatening and poorly controlled (especially among people with a low level of belief in the complexity of the world). These representations, in turn, may have led to an overestimation of risk, fatalism, and catastrophization among individual citizens, provoking the growth of dysfunctional COVID-19 fear. Perhaps, that is why we saw a positive link between the fate control axiom and the manifestations of COVID-19 fear in the Belarusian sample.

It is also interesting that we did not find significant links between individual values and dysfunctional fear of coronavirus infection (psychophysiological markers) among Russian and Kazakhstani youth. At the same time, Russian students did not show significant relationships between values and the psycho-emotional manifestations of this fear. Meanwhile, among Kazakhstani students, the high level of psycho-emotional manifestations of COVID-19 fear was correlated with the denial of the openness to change values, and the low level of this fear was related to a preference for these values, respectively.

This is quite logical and can be explained from the standpoint of Schwartz's theory. Schwartz (2014) emphasizes that people for whom the values of openness to change are more important than conservation values can be physiologically less sensitive to negative and/or exciting environmental features. Intrinsically, the openness to change values focus on growth and development, while the values of conservation relate to protection against anxiety. The people who attach special importance to the openness to change values tend to embrace novelty, variation, and new impressions. Therefore, the pandemic could be perceived not as an alarming event by them, but as an opportunity to achieve meaningful goals.

However, here, we should pay attention to another aspect. By studying the real fear of coronavirus infection under the conditions of the pandemic among the respondents of the three countries, we found no relationship between values and

dysfunctional fear across students from the two countries, namely Russia and Kazakhstan. This is inconsistent with the previous study, according to which micro and macro worries showed strong links to personal values (Schwartz et al., 2000). Probably, the relationships between fears and anxieties with values in hypothetical and real circumstances may differ, because of external contextual factors. At the same time, the links of values with COVID-19 fear found in the Belarusian sample were quite expected and can be explained by the basic provisions of Schwartz's theory about the anxiety-avoidant values and the anxiety-free values. So, psychophysiological manifestations of COVID-19 fear among Belarusian students were positively associated with values of self-enhancement, and psycho-emotional manifestations were connected to conservation values. That is, fear was related to the values that are associated with self-protection, control, and avoiding anxiety.

Let us also emphasize that we do not rule out the possibility of a reverse influence of COVID-19 fear on individual values. This explanation is especially pertinent since some published studies have confirmed a change in people's basic individual values under the influence of the pandemic (Daniel et al., 2021; Fischer et al., 2021). However, as part of this research, we are studying social axioms and individual values as predictors and information perception filters that can influence the formation of the fear of coronavirus infection.

Interestingly, individual values contributed less to the explanation of psychophysiological manifestations of COVID-19 fear than social axioms in all three samples. That is, the way a person perceives the world (social axioms) has a greater influence on the construction of fear in this case rather than what one aspires to (values). At the same time, psychological factors, both cultural (social axioms) and individual (values) levels, made the greatest contribution to the dysfunctional fear of COVID-19 among the students of Belarus. That is, this effect was observed among youth who were living under conditions of weak restrictive measures and denial of the pandemic by the state authorities, and a high risk of rapid and widespread infection.

According to the results of our research, social axioms and individual values play a significant role in the growth of COVID-19 fear when there is a clear mismatch between the official position of the state and the existing reality, *i.e.*, weak restrictive measures in Belarus, as well as under the possibility of varied assessments of the level of current threats, and moderate restrictive measures in Russia. This can lead to increased uncertainty and actualize special psychological mechanisms of attribution and coping in people, triggering specific social axioms and individual values. We observed these effects in the Belarusian and Russian samples, but not in the Kazakhstani sample.

At the same time, the students from Belarus and Kazakhstan did not differ in the level of dysfunctional fear of COVID-19, and COVID-19 fear among students of these two countries was significantly higher than among Russian students. That is, both Kazakhstani and Belarusian students could be included in the risk group for psychological trauma by fear of COVID-19. However, as we see, the role of psychological factors in the development of COVID-19 fear differed among the students in these countries, which is important to take into account when organizing psychological assistance for the pandemic and the post-pandemic periods.

Conclusion

This study enriches scientific knowledge in the field of assessing the influence of social axioms and individual values on the psychological well-being of people across different social contexts. The current study shows that the strategies for managing the pandemic can influence the level of COVID-19 fear and mediate links between this fear, social axioms, and individual values. Special attention should be paid to the population of countries and regions with the most severe and the least severe restrictive measures during the pandemic. As our research has shown, it is students from these types of countries who are at risk for psychological trauma by fear of COVID-19. In the context of future research, of particular interest are the psychological profiles of people who are especially afraid, or not at all afraid, of the COVID-19 in different sociocultural contexts, involving additional demographic, individual-psychological, and socio-psychological variables. In particular, considering the parameters of our study's samples, estimating gender differences in the impact of independent variables on the level of COVID-19 fear is an important task for future research.

Limitations

The present study had a number of limitations. We used cross-sectional correlation design, relied on self-report data, and used only quantitative data obtained predominantly with the help of the shortened versions of questionnaires. In addition, the limitations included the gender disparity within the three samples and convenience sampling. Due to the existing limitations and the fact that the study was exploratory, the conclusions of our research are probabilistic; and the results of the study are partially theoretical. We do not exclude the influence of other contextual factors on the discovered relationships. Additionally, we admit the possibility of another theoretical justification of the study, which may explain the inverse relationship between social axioms and values with fear of COVID-19.

Ethics Statement

The study and consent procedures were approved by the Ethics Committee of School of Psychology at HSE University (Approval no. 11, June 10, 2022).

Author Contributions

The idea of the article, the theory, the introduction, the statistical data, and the results were all conceived, carried out, and written by Nadezhda V. Murashcenkova.

Conflict of Interest

The author declares no conflict of interest.

Acknowledgements

This article is an output of a research project implemented as part of the Basic Research Program at the National Research University Higher School of Economics (HSE University).

References

- Abramov, A.V., Bozoyan, T.R., Dashkina, I.V., Demchuk, A.L., Emelianova, N.N., Kapitsyn, V.M., Karateev, A.Y., Kolesnikov, S.I., Knyazeva, M.S., Mustafin, B.E., Pashin, M.M., Kueva, P., Svechnikova, M.V., & Dong, H. (2022). Mobilizatsionnye mekhanizmy gosudarstv v politike protivodeystviya pandemii COVID-19 [Mobilization mechanisms of states in the policy of countering the COVID-19 pandemic]. *Vestnik Moskovskogo oblastnogo gosudarstvennogo universiteta* [Bulletin of Moscow Region State University], 1, 8–48. <https://doi.org/10.18384/2224-0209-2022-1-1107>
- Ahorsu, D.K., Lin, C.Y., Imani, V., Saffari, M., Griffiths, M.D., & Pakpour, A.H. (2022). The Fear of COVID-19 Scale: Development and initial validation. *International Journal of Mental Health and Addiction*, 20(3), 1537–1545. <https://doi.org/10.1007/s11469-020-00270-8>
- Al-Mahadin, S. (2020). Laughing it off: Coronavirus superspreaders, anxiety, and fear in Jordan and Australia. *Psychological Trauma: Theory, Research, Practice, and Policy*, 12(S1), S45–S46. <https://doi.org/10.1037/tra0000630>
- Al-Shannaq, Y., Mohammad, A.-A., & Khader, Y. (2022). Psychometric Properties of the Arabic Version of the Fear of COVID-19 Scale (FCV-19S) Among Jordanian Adults. *International Journal of Mental Health and Addiction*, 20(5), 3205–3218. <https://doi.org/10.1007/s11469-021-00574-3>
- Aristovnik, A., Keržič, D., Ravšelj, D., Tomažević, N., & Umek, L. (2020). Impacts of the COVID 19 pandemic on life of higher education students: a global perspective. *Sustainability*, 12(20), 8438. <https://doi.org/10.3390/su12208438>
- Arpaci, I., Karataş, K., & Baloğlu, M. (2020). The development and initial tests for the psychometric properties of the COVID-19 Phobia Scale (C19P-S). *Personality and Individual Differences*, 164, 110108. <https://doi.org/10.1016/j.paid.2020.110108>
- Asmundson, G.J.G., & Taylor, S. (2020). How health anxiety influences responses to viral outbreaks like COVID-19: What all decision-makers, health authorities, and health care professionals need to know. *Journal of Anxiety Disorders*, 71, 102211. <https://doi.org/10.1016/j.janxdis.2020.102211>
- Barrett, L.F. (2017). *How emotions are made: The secret life of the brain*. Houghton Mifflin Harcourt.
- Bavel, J.J.V., Baicker, K., Boggio, P.S., Capraro, V., Cichocka, A., Cikara, M., ... Willer, R. (2020). Using social and behavioural science to support COVID-19 pandemic response. *Nature Human Behaviour*, 4(5), 460–471. <https://doi.org/10.1038/s41562-020-0884-z>
- Boehnke, K., & Schwartz, S.H. (1997). Fear of war: Relations to values, gender, and mental health in Germany and Israel. *Peace and Conflict: Journal of Peace Psychology*, 3(2), 149–165. https://doi.org/10.1207/s15327949pac0302_3
- Boehnke, K., Stromberg, C., Regmi, M.P., Richmond, B.O., & Chandra, S. (1998). Reflecting the world “Out There”: A cross-cultural perspective on worries, values and well-being. *Journal of Social and Clinical Psychology*, 17(2), 227–247. <https://doi.org/10.1521/jscp.1998.17.2.227>
- Bond, M.H., Leung, K., Au, A., Tong, K., & Chemonges-Nielson, Z. (2004a). Combining social axioms with values in predicting social behaviours. *European Journal of Personality*, 18(3), 177–191. <https://doi.org/10.1002/per.509>
- Bond, M.H., Leung, K., Au, A., Tong, K.K., De Carrasquel, S.R., Murakami, F., Yamaguchi, S., Bierbrauer, G., Singelis, T., Broer, M., Boen, F., Lambert, S., Ferreira, M.C., Noels, K., Van Bavel, J.V., Safdar, S., Zhang, J., Chen, L., Šolcová, I. ... Lewis, J.R. (2004b). Culture-level dimensions of social axioms and their correlates across 41 cultures. *Journal of Cross-Cultural Psychology*, 35(5), 548–570. <https://doi.org/10.1177/0022022104268388>
- Chen, I.H., Chen, C.Y., Zhao, K.Y., Gamble, J.H., Lin, C.-Y., Griffiths, M.D., & Pakpour, A.H. (2022). Psychometric evaluation of fear of COVID-19 Scale (FCV-19S) among Chinese primary and middle schoolteachers, and their students. *Current Psychology (New Brunswick, N.J.)*, 1–17. Advance online publication. <https://doi.org/10.1007/s12144-021-02471-3>
- Cohen-Louck, K., & Levy, I. (2021). Viruism: The need for a new term describing COVID-19 impact in context of viral victimization. *Psychological Trauma: Theory, Research, Practice, and Policy*, 13(1), 1–8. <https://doi.org/10.1037/tra0000945>
- Daniel, E., Fischer, R., Bardi, A., Benish-Weisman, M., & Lee, J.A. (2022). Changes in personal values in pandemic times. *Social Psychological and Personality Science*, 13(2), 572–582. <https://doi.org/10.1177/194855062111024026>

- Deng, J., Zhou, F., Hou, W., Silver, Z., Wong, C.Y., Chang, O., ... Huang, E. (2021). The prevalence of depressive symptoms, anxiety symptoms and sleep disturbance in higher education students during the COVID-19 pandemic: A systematic review and meta-analysis. *Psychiatry Research*, 301, 113863. <https://doi.org/10.1016/j.psychres.2021.113863>
- Fischer, R., Bortolini, T., Pilati, R., Porto, J., & Moll, J. (2021). Values and COVID-19 worries: The importance of emotional stability traits. *Personality and Individual Differences*, 182, 111079. <https://doi.org/10.1016/j.paid.2021.111079>
- Frink, D.D., Rose, G.M., & Canty, A.L. (2004). The effects of values on worries associated with acute disaster: a naturally occurring quasi-experiment. *Journal of Applied Social Psychology*, 34(1), 85–107. <https://doi.org/10.1111/j.1559-1816.2004.tb02538.x>
- Hale, T., Angrist, N., Cameron-Blake, E., Hallas, L., Kira, B., Petherick, A., ... Tatlow, H. (2020, November). Variations in government responses to COVID-19. (BSG Working Paper No. 2020/032). Retrieved from <https://www.bsg.ox.ac.uk/covidtracker>
- Han, Q., Zheng, B., Agostini, M., Bélanger, J.J., Gützkow, B., Kreienkamp, J., ... Leander, N.P. (2021). Associations of risk perception of COVID-19 with emotion and mental health during the pandemic. *Journal of Affective Disorders*, 284, 247–255. <https://doi.org/10.1016/j.jad.2021.01.049>
- Harper, C.A., Satchell, L.P., Fido, D., & Latzman, R.D. (2021). Functional fear predicts public health compliance in the COVID-19 pandemic. *International Journal of Mental Health and Addiction*, 19(5), 1875–1888. <https://doi.org/10.1007/s11469-020-00281-5>
- Hui, C.-M., & Hui, N.H.-H. (2009). The mileage from social axioms: Learning from the past and looking forward. In K. Leung & M.-H. Bond (Eds.), *Psychological aspects of social axioms: Understanding global belief systems* (pp. 13–30). Springer Science + Business Media. https://doi.org/10.1007/978-0-387-09810-4_2
- Hui, V.K.Y., Bond, M.H., & Ng, T.S.W. (2007). General beliefs about the world as defensive mechanisms against death anxiety. *Omega: Journal of Death and Dying*, 54, 199–214. <https://doi.org/10.2190/8NQ6-1420-4347-H1G1>
- Hyde, J., Ryan, K.M., & Waters, A.M. (2019). Psychophysiological markers of fear and anxiety. *Current Psychiatry Reports*, 21, 56. <https://doi.org/10.1007/s11920-019-1036-x>
- Inzlicht, M., McGregor, I., Hirsh, J.B., & Nash, K. (2009). Neural markers of religious conviction. *Psychological Science*, 20(3), 385–392. <https://doi.org/10.1111/j.1467-9280.2009.02305.x>
- Jack, R.E., Crivelli, C., & Wheatley, T. (2018). Data-driven methods to diversify knowledge of human psychology. *Trends in Cognitive Sciences*, 1(22), 1–5. <https://doi.org/10.1016/j.tics.2017.10.002>
- Karáth, K. (2020). Covid-19: How does Belarus have one of the lowest death rates in Europe? *BMJ*, 370, m3543. <https://doi.org/10.1136/bmj.m3543>
- Laurin, K., Kay, A.-C., & Moscovitch, D.-A. (2008). On the belief in God: Towards an understanding of the emotional substrates of compensatory control. *Journal of Experimental Social Psychology*, 44(6), 1559–1562. <https://doi.org/10.1016/j.jesp.2008.07.007>
- Lazarus, R.S. (1991). Cognition and motivation in emotion. *American Psychologist*, 46(4), 352–367. <https://doi.org/10.1037/0003-066X.46.4.352>
- Lazarus, R.S. (1996). *Psychological stress and the coping process*. New York: McGraw-Hill.
- Lazarus, R.S., & Folkman, S. (1984). *Stress, appraisal, and coping*. New York: Springer.
- Leung, K., Au, A., Huang, X., Kurman, J., Niit, T., & Niit, K. (2007). Social axioms and values: A cross-cultural examination. *European Journal of Personality*, 21(2), 91–111. <https://doi.org/10.1002/per.615>
- Leung, K., & Bond, M.H. (Eds.). (2009). *Psychological aspects of social axioms: Understanding global belief systems*. Springer Science + Business Media. <https://doi.org/10.1007/978-0-387-09810-4>
- Leung, K., Bond, M.H., de Carrasquel, S.R., Munoz, C., Hernandez, M., Murakami, F., Yamaguchi, S., Bierbrauer, G., & Singelis, T.M. (2002). The search for universal dimensions of general beliefs about how the world functions. *Journal of Cross-Cultural Psychology*, 33(3), 286–302. <https://doi.org/10.1177/0022022102033003005>
- Li, W.-Q., Li, L., Jiang, D., & Liu, S. (2021). Fate control and ingroup bias in donation for the fight with the coronavirus pandemic: The mediating role of risk perception of COVID-19. *Personality and Individual Differences*, 171, 110456. <https://doi.org/10.1016/j.paid.2020.110456>

- Mailliez, M., Griffiths, M.D., & Carre, A. (2021). Validation of the French version of the Fear of COVID-19 Scale and its associations with depression, anxiety, and differential emotions. *International Journal of Mental Health and Addiction*, 1–15. <https://doi.org/10.1007/s11469-021-00499-x>
- Mertens, G., Duijndam, S., Smeets, T., & Lodder, P. (2021). The latent and item structure of COVID-19 fear: A comparison of four COVID-19 fear questionnaires using SEM and network analyses. *Journal of Anxiety Disorders*, 81, 102415. <https://doi.org/10.1016/j.janxdis.2021.102415>
- Mertens, G., Gerritsen, L., Duijndam, S., Saleminck, E., & Engelhard, I.M. (2020). Fear of the coronavirus (COVID-19): Predictors in an online study conducted in March 2020. *Journal of Anxiety Disorders*, 74, 102258. <https://doi.org/10.1016/j.janxdis.2020.102258>
- Nasledov, A. (2013). IBM SPSS Statistics 20 and AMOS: professional'nyy statisticheskii analiz dannykh [IBM SPSS Statistics 20 and AMOS: professional statistical data analysis]. St. Petersburg, Piter.
- Nestik, T.A., Deyneka, O.S., & Maksimenko, A.A. (2020). Sotsial'no-psikhologicheskie predposylki very v konspirologicheskie teorii proiskhozhdeniya COVID-19 i вовлеченност' v setevye kommunikatsii [Socio-psychological predictors of belief in conspiracy theories of the origin of COVID-19 and involvement in social media]. *Sotsial'naia psikhologiya i obshchestvo* [Social Psychology and Society], 11(4), 87–104. <https://doi.org/10.17759/sps.2020110407>
- Odintsova, M.A., Radchikova, N.P., & Yanchuk, V.A. (2021). Otsenka situatsii pandemii COVID-19 zhitelyami Rossii i Belarusi [Assessment of the COVID-19 pandemic situation by residents of Russia and Belarus]. *Sotsial'naia psikhologiya i obshchestvo* [Social Psychology and Society], 12(2), 56–77. <https://doi.org/10.17759/sps.2021120204>
- Ornell, F., Schuch, J.-B., Sordi, A.O., & Kessler, F. (2020). "Pandemic fear" and COVID-19: mental health burden and strategies. *Revista Brasileira de Psiquiatria (Sao Paulo, Brazil: 1999)*, 42(3), 232–235. <https://doi.org/10.1590/1516-4446-2020-0008>
- Pakpour, A.H., & Griffiths, M.D. (2020). The fear of COVID-19 and its role in preventive behaviors. *Journal of Concurrent Disorders*, 2(1), 58–63. <https://doi.org/10.54127/WCIC8036>
- Pokhrel, S., & Chhetri, R. (2021). A literature review on impact of COVID-19 pandemic on teaching and learning. *Higher Education for the Future*, 8(1), 133–141. <https://doi.org/10.1177/2347631120983481>
- Ren, S.-Y., Gao, R.-D., & Chen, Y.-L. (2020). Fear can be more harmful than the severe acute respiratory syndrome coronavirus 2 in controlling the corona virus disease 2019 epidemic. *World Journal of Clinical Cases*, 8(4), 652–657. <https://doi.org/10.12998/wjcc.v8.i4.652>
- Reshetnikov, V., Mitrokhin, O., Shepetovskaya, N., Belova, E., & Jakovljevic, M. (2020). Organizational measures aiming to combat COVID-19 in the Russian Federation: the first experience. *Expert Review of Pharmacoeconomics & Outcomes Research*, 20(6), 571–576. <https://doi.org/10.1080/14737167.2020.1823221>
- Reznik, A., Gritsenko, V., Konstantinov, V., Khamenka, N., & Isralowitz, R. (2021). COVID-19 Fear in Eastern Europe: Validation of the Fear of COVID-19 Scale. *International Journal of Mental Health and Addiction*, 19(5), 1903–1908. <https://doi.org/10.1007/s11469-020-00283-3>
- Satici, B., Saricali, M., Satici, S.A., & Griffiths, M.D. (2020). Intolerance of Uncertainty and Mental Well-being: Serial Mediation by Rumination and Fear of COVID-19. *International Journal of Mental Health and Addiction*, 1–12. Advance online publication. <https://doi.org/10.1007/s11469-020-00305-0>
- Schimmenti, A., Starcevic, V., Giardina, A., Khazaal, Y., & Billieux, J. (2020). Multidimensional assessment of COVID-19-Related Fears (MAC-RF): A theory-based instrument for the assessment of clinically relevant fears during pandemics. *Frontiers in Psychiatry*, 11, 748. <https://doi.org/10.3389/fpsy.2020.00748>
- Schwartz, S.H. (2015). Basic individual values: Sources and consequences. In D. Sander & T. Brosch (Eds.), *Handbook of value: Perspectives from economics, neuroscience, philosophy, psychology and sociology* (pp. 63–84). Oxford University Press. <https://doi.org/10.1093/acprof:oso/9780198716600.003.0004>
- Schwartz, S.H. (2003). Instructions for Computing Scores for the 10 Human Values and Using them in Analyses. In *Documentation for ESS-1*. http://ess.nsd.uib.no/ess/doc/ess1_human_values_scale.pdf
- Schwartz, S. (2014). Negativity bias and basic values. *Behavioral and Brain Sciences*, 37(3), 328–329. <https://doi.org/10.1017/S0140525X13002720>

- Schwartz, S.H. (1992). Universals in the content and structure of values: Theoretical advances and empirical tests in 20 countries. In M.-P. Zanna (Ed.), *Advances in Experimental Social Psychology*, 25 (pp. 1–65). New York: Academic Press. [https://doi.org/10.1016/S0065-2601\(08\)60281-6](https://doi.org/10.1016/S0065-2601(08)60281-6)
- Schwartz, S.H., Cieciuch, J., Vecchione, M., Davidov, E., Fischer, R., Beierlein, C., Ramos, A., Verkasalo, M., Lönnqvist, J., Demirutku, K., Dirilen-Gumus, O., & Konty, M. (2012). Refining the theory of basic individual values. *Journal of Personality and Social Psychology*, 103(4), 663–688. <https://doi.org/10.1037/a0029393>
- Schwartz, S.H., Melech, G., Lehmann, A., Burgess, S., Harris, M., & Owens, V. (2001). Extending the cross-cultural validity of the theory of basic human values with a different method of measurement. *Journal of Cross-Cultural Psychology*, 32(5), 519–542. <https://doi.org/10.1177/0022022101032005001>
- Schwartz, S.H., Sagiv, L., & Boehnke, K. (2000). Worries and values. *Journal of Personality*, 68(2), 309–346. <https://doi.org/10.1111/1467-6494.00099>
- Shaw, A., Joseph, S., & Alex Linley, P.A. (2005) Religion, spirituality, and posttraumatic growth: A systematic review. *Mental Health, Religion & Culture*, 8(1), 1–11. <https://doi.org/10.1080/1367467032000157981>
- Shpakou, A., Klimatkaia, L., Skoblina N., Baj-Korpak, Yu., Skarbaliene, A., Fedortsiv, O., ... Cherkasova, Yu. (2021). Rasprostranennost' odinochestva sredi studentov universitetov pyati evropeyskikh stran vo vremya pandemii COVID-19 [The prevalence of loneliness among university students from five European countries during the COVID-19 pandemic]. *Psychology. Journal of Higher School of Economics*, 18(4), 871–887. <https://doi.org/10.17323/1813-8918-2021-4-871-887>
- Solymosi, R., Jackson, J., Pösch, K., Yesberg, J.A., Bradford, B., & Kyprianides A. (2021). Functional and dysfunctional fear of COVID-19: a classification scheme. *Crime Science*, 10(4). <https://doi.org/10.1186/s40163-020-00137-2>
- Swedberg, R. (2021). Does speculation belong in social science research? *Sociological Methods & Research*, 50(1), 45–74. <https://doi.org/10.1177/0049124118769092>
- Tatarko, A.N., & Lebedeva, N.M. (2011). *Metody etnicheskoy i krosskul'urnoy psikhologii* [Methods of ethnic and crosscultural psychology]. Moscow, NIU-VSHE.
- Tatarko, A.N., & Lebedeva, N.M. (2020). Razrabotka i aprobatsiya sokrashchennoy versii metodiki «Sotsial'nye aksiomy» M. Bonda i K. Leunga [Developing and testing a short version of the Social Axioms Questionnaire by M. Bond and K. Leung]. *Kul'turno-istoricheskaya psikhologiya* [Cultural-Historical Psychology], 16(1), 96–110. <https://doi.org/10.17759/chp.2020160110>
- Taylor, S., Landry, C.A., Paluszek, M.M., Fergus, T.-A., McKay, D., & Asmundson, G.J.G. (2020). Development and initial validation of the COVID stress scales. *Journal of Anxiety Disorders*, 72, 102232. <https://doi.org/10.1016/j.janxdis.2020.102232>
- Tong, K.K., Chen, J.H., Yu, E.W., & Wu, A.M.S. (2020). Adherence to COVID-19 precautionary measures: applying the health belief model and generalised social beliefs to a probability community sample. *Applied Psychology: Health and Well-Being*, 12(4), 1205–1223. <https://doi.org/10.1111/aphw.12230>
- Tzur Bitan, D., Grossman-Giron, A., Bloch, Y., Mayer, Y., Shiffman, N., & Mendlovic, S. (2020). Fear of COVID-19 scale: psychometric characteristics, reliability and validity in the Israeli population. *Psychiatry Research*, 289, 113100. <https://doi.org/10.1016/j.psychres.2020.113100>
- Ulybina, E., & Baklanova, N. (2019). Otnoshenie k dvusmyslennosti i soglasie s ubezhdeniyami roditeley kak prediktory smeny otnosheniya k religii [Attitude to ambiguity and agreement with parents' beliefs as predictors of attitude shift to religion]. *Psikhologiya. Zhurnal Visshey shkoly ekonomiki* [Psychology. Journal of the Higher School of Economics], 16(2), 183–191 <https://doi.org/10.17323/1813-8918-2019-2-391-399>
- Wang, F., Zhang, L., Ding, L., Wang, L., & Deng, Y. (2022). Fear of COVID-19 among college students: a systematic review and meta-analysis. *Frontiers in Public Health*, 10. <https://doi.org/10.3389/fpubh.2022.846894>
- Weekly epidemiological update — 27 January 2021. Data as received by WHO from national authorities, as of 24 January 2021. Retrieved from <https://www.who.int/publications/m/item/weekly-epidemiological-update---27-january-2021>

Weekly epidemiological update on COVID-19 — 20 April 2021. Data as received by WHO from national authorities, as of 10am CET 18 April 2021. Retrieved from <https://www.who.int/publications/m/item/weekly-epidemiological-update-on-covid-19---20-april-2021>

Wichman, A.-L. (2010). Uncertainty and religious reactivity: Uncertainty compensation, repair, and inoculation. *European Journal of Social Psychology*, 40(1), 35–42. <https://doi.org/10.1002/ejsp.712>

Original manuscript received September 26, 2022

Revised manuscript accepted December 23, 2022

First published online March 15, 2023

To cite this article: Murashchenkova, N.V. (2023). Social Axioms and Individual Values as Predictors of COVID-19 Fear among University Students from Countries with Different Government Strategies for Managing the Pandemic. *Psychology in Russia: State of the Art*, 16(1), 44–65. DOI: 10.11621/pir.2023.0103

The Role of Income in System Justification

Elena R. Agadullina^{a*}

^a HSE University, Moscow, Russia

*Corresponding author. E-mail: eagadullina@gmail.com

Background. System justification theory asserts that people's motivation to defend, justify, and maintain the status quo depends on their socio-economic status. At the same time practically nothing is known about the mediators for the relationship between a person's income and his adherence to system justification.

Objective. The aim of this study was to clarify the role of income in motivating an individual to justify the system, taking into account as potential mediators of this relationship his sense of control over life and level of life satisfaction.

Design. In an online study (N = 410), a double sequential mediation model was tested, with an individual's income as an independent variable, his/her system justification as a dependent variable, and his/her perceived control over life and level of life satisfaction as mediators. The impact of education was controlled by inserting it into the model as a covariate.

Results. The results demonstrated that people with low incomes justify the system more than people with high incomes do. At the same time, there was a positive indirect effect of income on system justification, indicating that, compared to people with low incomes, those with high incomes had a more pronounced sense of control over their lives, which contributed to an increase in their level of life satisfaction, and was positively associated with justification of the status quo.

Conclusion. The results are discussed in terms of differences in the palliative function of system justification for individuals of different socio-economic status.

Keywords:
System justification, income, life satisfaction, control over life.

Introduction

System justification (SJ) is a process of rationalizing the existing social, economic, and political relationships between people with different social statuses as essential, legitimate, and fair (Jost & Banaji, 1994). One of the basic assumptions of SJ theory is that people of low status are more motivated to defend, justify, and maintain the status quo than those of higher status (the status-legitimacy hypothesis). This hypothesis describes a paradoxical assumption, according to which inequality in society is mainly supported by groups that suffer most from it. This assertion has become one of the most discussed theses of SJ theory.

Yet empirical testing of this status-legitimacy hypothesis has not confirmed it as far as subjective socio-economic status (SES) (perceived position in society in comparison with other social groups [see, for example, Adler et al., 2000]) is concerned. In particular, in various cross-cultural studies, subjective SES was positively associated with different elements of SJ: *i.e.*, trust in government and social institutions (Brandt, 2013; Brandt et al., 2020); perception of social justice (Caricati et al., 2012) and income distribution (Caricati, 2017); perception of the legitimacy of the status quo (Brandt et al., 2020); and the scores on the SJ scales (Vargas-Salfate, Paez, Khan, et al., 2018; Vargas-Salfate, Paez, Liu, et al., 2018).

The positive relationship between subjective SES and SJ can be explained by the fact that people often cannot adequately assess their social status; they tend to place themselves in the middle of the social hierarchy (see, for example, Evans & Kelley, 2004). As a result, people with objectively low status often overestimate their social position, which allows them to maintain a positive self-representation and self-esteem, and leads them to defend their overvalued position, including by justifying the existing system (Brandt et al., 2020).

As for the objective SES (education level and income) (Kraus et al., 2011), there are much less data and more ambiguous findings. When objective SES was operationalized by education, it was almost always negatively associated with various forms of SJ (Brandt, 2013; Li, Yang, et al., 2020). This is because the level of conservatism mediates the relationship between education and SJ: less-educated people are more conservative (Jost et al., 2017; Li, Yang, et al., 2020), and conservatism predicts SJ (Vargas-Salfate, Paez, Liu, et al., 2018).

The situation regarding the effect of income on SJ is more complicated. Li with colleagues (2020) showed that income had either a significant negative (Studies 1–3) or non-significant correlation with SJ (Studies 4–5). Vargas-Salfate with colleagues (2018), using cross-cultural data, found that income was negatively associated with willingness to justify the system, while Brandt (2013) demonstrated that for different countries, income was not associated with trust in government and public institutions. These conflicting results can reflect a variety of reasons, such as the mixing of the effects of education and income on SJ, since education is often a precondition for well-paid and high-status jobs, or existing indirect effects that determine the relationship between income and SJ. The main aim of this study was to clarify the role of income in determining SJ.

Mediators for the relationship between income and system justification

According to the basic assumption of SJ theory, people with a low social status are more likely to justify the system because they feel cognitive dissonance between the need to maintain a positive representation about themselves and their ingroup, and the recognition that the status quo assigns them a low social status (Jost & Banaji, 1994). The need to resolve this dissonance is realized, among other things, through SJ. However, while it has been shown that the level of conservatism explains the link between education and SJ, there are no data about mediators for the relationship between income and SJ. At the same time, previous studies on how income is related to different psychological outcomes (Manstead, 2018). Pitlik and Rode (2016) showed that income is linked with perceived control over life: the lower the income, the fewer alternatives individuals have to choose from; therefore, their sense of control over life decreases.

Kraus and his colleagues (2012) summarized the existing findings on the differences between people with various income levels and found that low-income individuals were more motivated to cope with current threats and make situational attributions, while individuals with a high income were more focused on achieving their goals and favored dispositional attributions. For its part, a sense of control over life also increases a person's willingness to achieve goals, which, in turn, contributes to maintaining high social status and material well-being (Johnson & Krueger, 2006). Moreover, a sense of control over life allows individuals to maintain subjective well-being and significantly enhances their levels of happiness and life satisfaction (Inglehart et al., 2008; Klonowicz, 2001; Myers & Diener, 1995).

Income also makes a significant contribution to life satisfaction (Boyce et al., 2010; Graafland & Lous, 2018; Salinas-Jiménez et al., 2010). Howell and Howell (2008) showed in their meta-analysis that life satisfaction increases with income, as higher income creates more opportunities to meet basic physiological and psychological needs (e.g., good nutrition, safety, and so on), while low income is often accompanied by stress due to the difficulty or inability to meet daily needs. Thus, income, both directly and indirectly via perceived control over life, impacts life satisfaction.

For its part, life satisfaction is associated with SJ. According to SJ theory, justification of the status quo fulfills a palliative function as it enhances positive, and reduces negative, experiences (Jost & Hunyady, 2005). A comparative study conducted in 18 countries confirmed that SJ was positively associated with life satisfaction and negatively with anxiety and depression, regardless of the person's social status and the level of inequality in society (Vargas-Salfate, Paez, Khan, et al., 2018). Li with colleagues (2020), based on data from China, also confirmed that SJ was positively associated with life satisfaction, regardless of the social class to which the individuals belong.

Taken altogether, these results enable us to conclude that the relationship between income and SJ can be mediated by psychological attitudes that are associated with high or low income. Thus, the main research question of this study: How do

different psychological variables mediate the relationship between income and SJ? The answer to this question was sought through testing the hypothesis: High income increases an individual's sense of control, which increases his or her life satisfaction, which, in turn, increases SJ.

Methods

Participants

The sample consisted of 410 Russians (66.3 % women, $M_{\text{age}} = 38.02$, $SD = 10.53$) who were recruited for an online study and received a participation fee. Most of the respondents were native Russians (92.9%); 48.8% were non-believers and 37.1% were Orthodox; 50.5% had completed higher education; and 37.6% lived in cities with a population of more than a million, including Moscow and St. Petersburg.

Procedure and Measures

The respondents filled out an informed consent form, after which they were introduced to the purpose of the study and provided with instructions. They next completed the questionnaires about life satisfaction, perceived control over life, and SJ, and then answered the social-demographic questions.

Life satisfaction was measured using ratings from the World Values Survey (WVS): "How satisfied are you with your life in general?" The respondents had to rate their degree of satisfaction on a scale from 0 (*completely dissatisfied*) to 10 (*completely satisfied*).

Control over life was also measured using WVS ratings: "Some people feel they have completely free choice and control over their lives, while other people feel that what they do has no real effect on what happens to them. To what extent do you control the course of your life?" Respondents had to rate how much, in their opinion, they had freedom of choice and control over their lives, on a scale from 1 (*I have absolutely no control over my life and what happens in it*) to 7 (*I am completely in control of my life and what happens in it*).

System justification was measured by the Russian version of the system justification scale (Agadullina et al., 2021), which included five statements (e.g., "In Russia today, life does not need any significant changes") ($\alpha = 0.91$). The level of agreement with the statement was assessed on a scale from 1 (*strongly disagree*) to 9 (*strongly agree*).

Income was measured by the statement: "Please, indicate your income per month." Respondents had to choose one of 14 options: 1 = *less than 15,000 rubles per month*; 2 = *from 15,000 to 20,000 rubles per month*; 3 = *from 20,000 to 30,000 rubles per month*; and so on up to 14 (*more than 200,000 rubles per month*).

Education was measured by asking the respondents to state their highest level of education from the options: 1) primary, 2) secondary (school), 3) secondary special (college), 4) incomplete higher education, 5) completed higher education, and 6) two or more higher education degrees.

Data analysis

A double sequential mediation model was used for data analyses in the PROCESS v 3.3 (model 6) for SPSS (Hayes & Preacher, 2014). An individual's income level was used as an independent variable, SJ as a dependent variable, and perceived control over life and the level of life satisfaction as the mediators. The effect of education was controlled by inserting it into the model as a covariate. The indirect effect was tested using a bootstrapping procedure (10,000 random samples). If the 95% bootstrapping confidence interval did not include zero, then the effect was considered significant (MacKinnon et al., 2004).

Results

Descriptive statistics

Table 1 shows the descriptive statistics and correlations between the variables. In full accordance with previous findings, income positively correlated with perceived control over life and life satisfaction; at the same time, these variables correlated with each other and with SJ.

Education was not correlated with life satisfaction and a sense of control over life (the higher the level of education, the less perceived control over life respondents felt). Despite the significant positive correlation between income and education, these variables showed different patterns in relation to SJ. So, SJ was positively associated with income and negatively associated with education.

Table 1

Descriptive statistics and intercorrelations for variables.

	M	SD	Min	Max	Skewness	Kurtosis	1	2	3	4
1. Life satisfaction	5.51	2.19	1	10	-.135	-.782	-			
2. System justification	3.88	1.87	1	9	.233	-.671	.494**	-		
3. Income	3.33	2.10	1	14	1.397	2.993	.256**	.120*	-	
4. Control over life	4.76	1.33	1	7	-.147	-.347	.561**	.382**	.153**	-
5. Education	4.25	1.24	2	6	-.050	-.439	.090	-.023*	.201**	-.018

Note. ** $p < .01$, * $p < .05$

Double sequential mediation model

The results presented in Table 2 demonstrate that income had a positive effect on control over life [$B = .10$, $t(409) = 3.26$, $p = .001$] and life satisfaction [$B = .17$, $t(409) = 3.88$, $p < .001$]. At the same time, income had a negative effect on system justification [$B = -.01$, $t(409) = -.06$, $p = .042$], demonstrating that people with low

income justify the system more than those with high income, which can be considered as a confirmation of the status legitimization hypothesis. The indirect effect of income on SJ via life satisfaction [$B = .06$, 95% CI (.03, .10)], as well as via control over life [$B = .02$, 95% CI (.01, .04)], was significant, indicating that people with a high income were more satisfied with life and felt more control over life than those with low income. The results of double sequential mediation via control over life and life satisfaction were also significant [$B = .03$, 95% CI (.01, .06)].

In general, these results confirmed that people with high incomes felt more control over life compared to those with low incomes. This increased their life satisfaction, which, in turn, increased their willingness to justify the status quo. Thus, the direct and indirect effects of income on system justification showed opposite outcomes. Moreover, psychological variables associated with income completely mediated its relationship with SJ; the total effect was significant [$B = .11$, $t(409) = 2.59$, $p = .01$].

The level of education had the expected negative significant direct effect on SJ [$B = -.09$, $t(409) = -1.34$, $p = .034$], but the total effect of education on SJ was non-significant [$B = -.07$, $t(409) = -.98$, $p = .328$].

Table 2

The results of the double sequential mediation model.

	Control over life		Life satisfaction		System justification	
	Beta (SE)	95% CI	Beta (SE)	95% CI	Beta (SE)	95% CI
Income	.10** (.03)	.04, .17	.17*** (.04)	.08, .25	-.01* (.01)	-.08, -.01
Control over life			.89*** (.07)	.75, 1.02	.21** (.07)	.06, .35
Life satisfaction					.35*** (.05)	.27, .44
Education	-.05 (.05)	-.15, .05	.12 (.07)	-.02, .26	-.09* (.07)	-.21, -.04
Constant	4.64*** (.24)	4.17, 5.11	0.23 (.45)	-.65, 1.11	1.31** (.41)	.51, 2.11
	$R^2 = .03$		$R^2 = .35$		$R^2 = .26$	
Total effect income on system justification					.11** (.04)	.03, .20
Indirect effect						
Income — control over life — system justification					.02 (.01)	.01, .04
Income — life satisfaction — system justification					.06 (.02)	.03, .10
Income — control over life — life satisfaction — system justification					.03 (.01)	.01, .06

Note. * $p < .05$, ** $p < .01$, *** $p < .001$

Discussion

The aim of this study was to clarify the role of income in SJ and to investigate the relationship between income and SJ, taking into account as potential mediators perceived control over life and the level of life satisfaction.

The results confirmed that the status legitimacy hypothesis is supported when the relationship between objective income and SJ is studied, regardless of the psychological variables associated with high or low income. Following the assumption of SJ theory (Jost & Banaji, 1994), and previously obtained cross-cultural results (Vargas-Salfate et al., 2018), it was found that low-income individuals justified the status quo more than high-income individuals. The main hypothesis of this study, that the relationship between income and SJ can be mediated by psychological variables associated with high and low income, has also been confirmed.

In previous studies, it has been shown that higher income increased feelings of control over life (Kraus, Piff, Mendoza-Denton, et al., 2012; Pitlik & Rode, 2016) and life satisfaction (Boyce et al., 2010; Graafland & Lous, 2018; Salinas-Jiménez et al., 2010). For their part, both the degree of control over life and life satisfaction contribute to strengthening SJ (Jost & Hunyady, 2005; Vargas-Salfate, Paez, Khan, et al., 2018). Thus, this study reproduced the main results obtained in previous studies. The main new contribution of our results was that they demonstrated that including the psychological mediators in the analysis of the relationship between income and SJ completely changes the results, since they contribute to the fact that people with high incomes begin to justify the system more than those with low incomes.

These results highlight the differences that the palliative function of SJ can have for groups of different status. The direct negative effect of income on SJ indicates that system-justifying ideology may help people with low status cope with negative emotions related to their low social position and their inability to fulfill the important physiological and psychological needs (Vargas-Salfate, Paez, Khan, et al., 2018). However, for low-status groups this palliative effect on subjective well-being is short-term; in the long term, low social status leads to a significant decrease in an individual's subjective well-being, and SJ is not able to neutralize its negative consequences (Jost & Hunyady, 2003). By contrast, for high-status groups, SJ is positively and strongly associated with well-being in both the short and long term. In other words, the rich become richer, since subjective well-being is added to high material well-being, while poor people can increase their well-being in the short term by justifying the system, but in the long term, they suffer from the system and increasingly justify it less.

In a broader context, the results obtained raise several questions, especially relating to the debate about subjective and objective measures in psychology. Obviously, one should separate subjective and objective status when it comes to testing the status legitimacy hypothesis, since when social status is operationalized through income or education, this hypothesis is more likely to be confirmed. Li with colleagues (2020) suggested that many of the conflicting results related to the reasons for justifying the status quo may be precisely associated with differences in the operationalization of perceived status. Undoubtedly, further reflection on these differences is required within the framework of SJ theory.

Moreover, even when it comes to objective status, the effects of income and education must be considered separately. In the present study, education had a negative effect on SJ, which confirms previous findings (Jost et al., 2017; Li, Yang, et al., 2020). Previous studies have also found that both income and education can be negatively

associated with different system-justifying ideologies such as right-wing authoritarianism (RWA) and social dominance orientation (SDO) and prejudice, but the effect of education is stronger than the effect of income (Carvacho et al., 2013; Schiefer, 2013). This trend is explained by the fact that education is inextricably linked to the inculcation of democratic and egalitarian values (Hainmueller & Hiscox, 2007), the maintenance of which is less dependent on situational circumstances, while income can be highly dependent on different socio-economic conditions (for example, an economic crisis, high unemployment, low demand for certain professions, etc.).

Limitations

The presented research has several limitations. First of all, the measurements used for control over life and life satisfaction are more typical of sociological research (only one item for each construct). This could have somewhat oversimplified the researched reality. Second, the study did not take into account other potential mediators (e.g., conservatism). For example, Johnson and Krueger (2006) demonstrated that income satisfaction fully mediated the relationship between real income and life satisfaction. At the same time, the broader socio-cultural and socio-economical contexts are no less important. In countries with low economic development, an increase in income makes a large contribution to life satisfaction, primarily by increasing the ability to fulfill physiological needs. But in economically developed countries, this connection is less pronounced, since the needs for self-realization and various psychological needs begin to play a larger role than physiological ones (Oishi et al., 1999).

Russia, where this study was conducted, belongs to the group of countries with dominant survival values (in contrast to self-expression values) (World Values Survey, 2020) and is not a typical WEIRD (Western, Educated, Industrialized, Rich, and Democratic) country (Henrich et al., 2010). As a result, for Russians there may be a stronger relationship between income and life satisfaction, and hence a more pronounced indirect effect of income on SJ via life satisfaction than in other developed countries with other core values. In future studies, it would be productive to expand the variables included in the analysis. For the correct interpretation of this study's results, it is necessary to take into account the described limitations.

Conclusion

The results confirmed that the relationship between income and SJ is mediated by psychological variables associated with high and low income (perceived control over life and the level of life satisfaction). Undoubtedly, both the direct and indirect relationships between income, education, and SJ need to be studied further in different socio-economic and cultural contexts to draw deeper conclusions.

Ethics Statement

The author confirms that this manuscript adheres to the APA ethical guidelines and the author's national ethics guidelines.

Informed Consent from the Participants' Legal Guardians (if the participants were minors)

All respondents filled out the informed consent form.

Conflict of Interest

The author declares no conflict of interest.

Acknowledgements

This research was supported by Russian Science Foundation (Project No. 20-18-00142)

References

- Adler, N., Adler, N.E., Epel, E S., Castellazzo, G., & Ickovics, J.R. (2000). Relationship of Subjective and Objective Social Status With Psychological and Physiological Functioning: Preliminary Data in Healthy White Women. *Health Psychology, 19*(6), 586–592. <https://doi.org/10.1037/0278-6133.19.6.586>
- Agadullina, E., Ivanov, A., & Sarieva, I. (2021). How Do Russians Perceive and Justify the Status Quo: Insights From Adapting the System Justification Scales. *Frontiers in Psychology, 12*(October), 1–12. <https://doi.org/10.3389/fpsyg.2021.717838>
- Boyce, C J., Brown, G.D.A., & Moore, S.C. (2010). Money and Happiness: Rank of Income, Not Income, Affects Life Satisfaction. *Psychological Science, 21*(4), 471–475. <https://doi.org/10.1177/0956797610362671>
- Brandt, M.J. (2013). Do the Disadvantaged Legitimize the Social System? A Large-Scale Test of the Status — Legitimacy Hypothesis. *Journal of Personality and Social Psychology, 104*(5), 765–785. <https://doi.org/10.1037/a0031751>
- Brandt, M.J., Kuppens, T., Spears, R., Andrighetto, L., Autin, F., Babincak, P., ... Zimmerman, J.L. (2020). Subjective Status and Perceived Legitimacy across Countries. *European Journal of Social Psychology, ejsp.2694*. <https://doi.org/10.1002/ejsp.2694>
- Caricati, L. (2017). Testing the Status-Legitimacy Hypothesis: A Multilevel Modelling Approach to the Perception of Legitimacy in Income Distribution in 36 Nations. *The Journal of Social Psychology, 5*, 532–540. <https://doi.org/10.1080/00224545.2016.1242472>
- Caricati, L., & Lorenzi-cioldi, F. (2012). Does status matter? Testing hypotheses from strong form of System Justification Theory. *Revue Internationale de Psychologie Sociale, 25*(1), 67–95.
- Carvacho, H., Zick, A., Haye, A., González, R., Manzi, J., Kocik, C., & Bertl, M. (2013). On the relation between social class and prejudice: The roles of education, income, and ideological attitudes. *European Journal of Social Psychology, 43*(4), 272–285. <https://doi.org/10.1002/ejsp.1961>
- Evans, M.D., & Kelley, J. (2004). Subjective social location: Data from 21 nations. *International Journal of Public Opinion Research, 16*, 3–38. <https://doi.org/10.1093/ijpor/16.1.3>
- Graafland, J., & Lous, B. (2018). Economic Freedom, Income Inequality, and Life Satisfaction in OECD Countries. *Journal of Happiness Studies, 19*(7), 2071–2093. <https://doi.org/10.1007/s10902-017-9905-7>
- Hainmueller, J., & Hiscox, M.J. (2007). Educated preferences: Explaining attitudes toward immigration in Europe. *International Organization, 61*(2), 399–442. <https://doi.org/10.1017/S0020818307070142>
- Hayes, A.F., & Preacher, K J. (2014). Statistical mediation analysis with a multicategorical independent variable. *British Journal of Mathematical and Statistical Psychology, 67*(3), 451–470. <https://doi.org/10.1111/bmsp.12028>
- Henrich, J., Heine, S.J., & Norenzayan, A. (2010). The weirdest people in the world? *Behavioral and Brain Sciences, 33*(2–3), 61–83. <https://doi.org/10.1017/S0140525X0999152X>

- Howell, R.T., & Howell, C.J. (2008). The relation of economic status to subjective well-being in developing countries: A meta-analysis. *Psychological Bulletin*, 134(4), 536–560. <https://doi.org/10.1037/0033-2909.134.4.536>
- Inglehart, R., Foa, R., Peterson, C., & Welzel, C. (2008). Development, Freedom, and Rising Happiness: A Global Perspective (1981–2007). *Perspectives on Psychological Science*, 3(4), 264–285. <https://doi.org/10.1111/j.1745-6924.2008.00078.x>
- Johnson, W., & Krueger, R.F. (2006). How Money Buys Happiness: Genetic and Environmental Processes Linking Finances and Life Satisfaction. *Journal of Personality and Social Psychology*, 90(4), 680–691. <https://doi.org/10.1037/0022-3514.90.4.680>
- Jost, J., & Hunyady, O. (2003). The psychology of system justification and the palliative function of ideology. *European Review of Social Psychology*, 13(1), 111–153. <https://doi.org/10.1080/10463280240000046>
- Jost, J.T., & Banaji, M.R. (1994). The role of stereotyping in system-justification and the production of false consciousness. *British Journal of Social Psychology*, 33(1), 1–27. <https://doi.org/10.1111/j.2044-8309.1994.tb01008.x>
- Jost, J.T., & Hunyady, O. (2005). Antecedents and Consequences of System-Justifying Ideology. *Current Directions in Psychological Science*, 14(5), 260–265. <https://doi.org/10.1111/j.0963-7214.2005.00377.x>
- Jost, J.T., Langer, M., Badaan, V., Azevedo, F., Etchezahar, E., Ungaretti, J., & Hennes, E.P. (2017). Ideology and the limits of self-interest: System justification motivation and conservative advantages in mass politics. *Translational Issues in Psychological Science*, 3(3), e1–e26. <https://doi.org/10.1037/tps0000127>
- Klonowicz, T. (2001). Discontented people: Reactivity and locus of control as determinants of subjective well-being. *European Journal of Personality*, 15(June 2000), 29–47. <https://doi.org/10.1002/per.387>
- Kraus, M.W., Piff, P.K., & Keltner, D. (2011). Social class as culture: The convergence of resources and rank in the social realm. *Current Directions in Psychological Science*, 20(4), 246–250. <https://doi.org/10.1177/0963721411414654>
- Kraus, M.W., Piff, P.K., Mendoza-denton, R., Rheinschmidt, M.L., & Keltner, D. (2012). Social Class, Solipsism, and Contextualism: How the Rich Are Different From the Poor. *Psychological Review*, 119(3), 546–572. <https://doi.org/10.1037/a0028756>
- Li, W., Wu, J., & Kou, Y. (2020). System Justification Enhances Life Satisfaction of High- and Low-Status People in China. *Social Psychological and Personality Science*, 11(5), 588–596. <https://doi.org/10.1177/1948550619866182>
- Li, W., Yang, Y., Wu, J., & Kou, Y. (2020). Testing the Status-Legitimacy Hypothesis in China: Objective and Subjective Socioeconomic Status Divergently Predict System Justification. *Personality and Social Psychology Bulletin*, 46(7), 1044–1058. <https://doi.org/10.1177/0146167219893997>
- MacKinnon, D., Lockwood, C., & Williams, J. (2004). Confidence Limits for the Indirect Effect: Distribution of the Product and Resampling Methods. *Multivariate Behavioral Research*, 39(1), 99–128. <https://doi.org/10.1207/s15327906mbr3901>
- Manstead, A.S.R. (2018). The psychology of social class: How socioeconomic status impacts thought, feelings, and behaviour. *British Journal of Social Psychology*, 57(2), 267–291. <https://doi.org/10.1111/bjso.12251>
- Myers, D.G., & Diener, E. (1995). Who Is Happy? *Psychological Science*, 6(1), 10–19. <https://doi.org/10.1111/j.1467-9280.1995.tb00298.x>
- Oishi, S., Diener, E.F., Lucas, R.E., & Suh, E.M. (1999). Cross-cultural variations in predictors of life satisfaction: Perspectives from needs and values. *Personality and Social Psychology Bulletin*, 25(8), 980–990. <https://doi.org/10.1177/01461672992511006>
- Pitlik, H., & Rode, M. (2016). Free to choose? Economic freedom, relative income, and life control perceptions. *International Journal of Wellbeing*, 6(1), 81–100. <https://doi.org/10.5502/ijw.v6i1.390>
- Salinas-Jiménez, M. del M., Artés, J., & Salinas-Jiménez, J. (2010). Income, Motivation, and Satisfaction with Life: An Empirical Analysis. *Journal of Happiness Studies*, 11(6), 779–793. <https://doi.org/10.1007/s10902-010-9185-y>
- Schiefer, D. (2013). Cultural Values and Group-Related Attitudes: A Comparison of Individuals With and Without Migration Background Across 24 Countries. *Journal of Cross-Cultural Psychology*, 44(2), 245–262. <https://doi.org/10.1177/0022022112444898>

- Vargas-Salfate, S., Paez, D., Khan, S.S., Liu, J.H., & Gil de Zúñiga, H. (2018). System justification enhances well-being: A longitudinal analysis of the palliative function of system justification in 18 countries. *British Journal of Social Psychology*, 57(3), 567–590. <https://doi.org/10.1111/bjso.12254>
- Vargas-Salfate, S., Paez, D., Liu, J.H., Pratto, F., & Gil de Zúñiga, H. (2018). A Comparison of Social Dominance Theory and System Justification: The Role of Social Status in 19 Nations. *Personality and Social Psychology Bulletin*, 44(7), 1060–1076. <https://doi.org/10.1177/0146167218757455>
- World Values Survey. (2020). *Cultural map*. Retrieved from <https://www.worldvaluessurvey.org/WVSContents.jsp>

Original manuscript received May 24, 2022
Revised manuscript accepted November 1, 2022
First published online March 30, 2023

To cite this article: Agadullina, E.R. (2023). The Role of Income in System Justification. *Psychology in Russia: State of the Art*, 16(1), 66–76. DOI: 10.11621/pir.2023.0104

The Relationship Between Perceived Discrimination, Acculturation Attitudes, and Adaptation among Anglophone African Immigrants in Russia: The Moderating Role of Neuroticism

Sepase K. Ivande^{a, b*}, Tatiana Ryabichenko^{b, c}

^a *Motivation and Intercultural Relations Lab, Department of Psychology, University of Victoria, BC, Canada*

^b *School of Psychology, HSE University, Moscow, Russia*

^c *International Laboratory for Social Integration Research, HSE University, Moscow, Russia*

*Corresponding author. Email: kingsleyivande@uvic.ca

Background. Perceived discrimination is an acculturative stressor that negatively predicts psychological and socio-cultural adaptation, partially mediated by the individual's acculturation attitudes. However, despite being under similar conditions of high perceived discrimination, some African immigrants in Russia appear to adapt more successfully than others. Why the individual differences? Neuroticism is a trait that intensifies the experience of negative emotions and sensitivity to stress. Perhaps it amplifies the reaction to acculturative stressors (e.g., perceived discrimination) in terms of acculturation attitudes, with significant implications for adaptation.

Objective. This study sought to determine whether the personality trait of neuroticism influences how African immigrants in Russia react to perceived discrimination in terms of their acculturation attitudes and how this may relate to adaptation.

Design. A moderated mediation analysis was carried out, investigating neuroticism as a moderator in the relationship between perceived discrimination, acculturation attitudes, and adaptation of African immigrants in Russia ($N = 157$).

Results. Perceived discrimination was found to be strongly associated with poor psychological and sociocultural adaptation, which was partially mediated by the integration attitude; neuroticism strengthened this indirect negative association.

Keywords: Perceived discrimination, neuroticism, acculturation attitudes, psychological adaptation, sociocultural adaptation, African immigrants, Russia

Conclusion. When highly neurotic African immigrants perceived elevated levels of discrimination, they were more averse to adopting a positive attitude toward integration, and as a result, were more maladapted. This result suggests that the differences in the levels of adaptation among African immigrants in Russia under similar conditions of high perceived discrimination may be partially due to their levels of neuroticism.

Introduction

The past few decades have seen a significant increase in the African immigrant population in the Russian Federation (Bondarenko, 2017; Bondarenko, Googueva et al., 2009; Fidan & Aras, 2010; Simmons, 2014). The number of African immigrants in Russia is estimated to be more than 50,000 and is forecast to steadily rise over the coming years (Bondarenko, 2017; Gribanova, 2009). Despite the burgeoning population of African immigrants in Russia, there have only been a handful of studies on the acculturation of Africans in Russia (Boltovskaja, 2010; Bondarenko, 2017; Bondarenko et al., 2009; J. Allina-Pisano & E. Allina-Pisano, 2007; Simmons, 2014).

Bondarenko et al. (2009) interviewed some African immigrants on their life experiences as immigrants in Russia while studying their sociocultural adaptation. They found that most of the interviewees reported a high level of perceived discrimination and appeared to be relatively maladapted in Russian society. However, those who regarded themselves as “well-adapted” were more likely to consider native Russians’ attitudes toward them as positive or tolerant, meaning that they perceived less discrimination (Bondarenko, 2017). It is well established that one of the main acculturation conditions that impedes successful adaptation of immigrants, in general, is perceived discrimination from the host culture (Berry et al., 2006; Berry & Sabatier, 2010; Güler & Yıldırım, 2022; Hashemi et al., 2019; Jasinskaja-Lahti & Liebkind, 2001; Kulis et al., 2009; Noh & Kaspar, 2003; Robinson, 2005; Te Lindert et al., 2008). Perceived discrimination is not just detrimental to adaptation directly but also indirectly through acculturation attitudes, as it reduces the possibility of adopting a positive attitude toward integration, and thus impedes successful adaptation. In this regard, perceived discrimination possibly influences the acculturation attitudes of African immigrants in Russia, which could explain their varying levels of adaptation.

Although the majority of the African immigrants Bondarenko and colleagues interviewed seemed maladapted in Russian society, a handful appeared well-adapted and integrated. Most of the well-adapted and integrated African immigrants were highly educated Soviet or Russian university alumni (Bondarenko, 2017; Bondarenko et al., 2009). However, there were cases of African immigrants who managed to successfully integrate and adapt to Russian society despite being under stressful acculturation conditions like perceived discrimination and lack of access to quality education (Simmons, 2014). This indicates the salience of other factors that might be influencing their psychological and sociocultural adaptation.

Research has identified several other factors that play a role in the acculturation process. These include perceived ethnic support, personality traits, etc. (Arends-Tóth & Van de Vijver, 2006; Hasan et al., 2021; Kvernmo & Heyerdahl, 2004; Van der Zee et al., 2016). Some of these are potential moderators in the relationship between perceived discrimination, acculturation attitudes, and adaptation. When evaluating variance among individuals in similar sociocultural circumstances, it is logical to consider dispositional characteristics like personality traits as possible causes.

Perceived discrimination is an acculturative stressor that elicits negative emotions (Berry, 2006; Britt-Spells et al., 2018). In this regard, neuroticism is particularly intriguing because it is the trait that determines sensitivity to stress and consequent negative emotions (Gunthert et al., 1999; McCrae & John, 1992; Steenhaut et al., 2018). Thus, individuals showing higher levels of neuroticism may be more vulnerable to the negative emotions elicited by perceived discrimination, potentially intensifying their reaction to discrimination. The issue thus arises: does neuroticism amplify the detrimental effects of perceived discrimination on adaptation? Previous research has revealed that certain components of neuroticism (*e.g.*, emotional reactivity, or an individual's tendency to react to stressful events with negative affect) amplify the direct negative impact of perceived discrimination on psychological well-being (Stein et al., 2016).

However, there is still a gap in terms of how neuroticism may influence the indirect impact of perceived discrimination on well-being/adaptation, such as how neuroticism may interact with perceived discrimination to predict one's acculturation attitude and its implication for adaptation. Thus, this study aimed to determine the moderating role of neuroticism in the indirect relationship between perceived discrimination and adaptation via the acculturation attitudes of African immigrants in Russia. The results could offer insight into how and why some African immigrants, under similar stressful acculturation conditions like high perceived discrimination, adapted better than others.

The Conceptual Framework of Acculturation

Acculturation can be defined as "the dual process of cultural and psychological change that takes place as a result of contact between two or more cultural groups and their members" (Berry, 2005, p. 698). According to the framework established by Arends-Toth and van de Vijver (2006), acculturation variables can be divided into three groups: acculturation conditions, orientations, and outcomes. Acculturation conditions, or the background and context under which the acculturation process occurs (*e.g.*, perceived discrimination, personality traits, etc.). The variations in conditions can influence the immigrant's acculturation orientation/attitudes (*i.e.*, how the acculturating groups or individuals decide to become involved with and relate with each other).

Underlying the acculturation attitudes are the issues of maintaining one's heritage/ethnic culture and/or adopting the mainstream culture. The intersections of these two issues result in four possible acculturation attitudes: 1) integration attitude (engage in both the heritage and mainstream cultures); 2) assimilation attitude (reject their heritage culture and adopt the mainstream culture); 3) separation at-

titude (maintain their heritage and reject the mainstream culture); and 4) marginalization attitude (reject both the heritage and mainstream cultures) (Berry, 2005). Which acculturation attitude is chosen can then influence the level of adaptation, which is typically assessed with two latent variables: psychological adaptation (feelings of well-being and satisfaction), and sociocultural adaptation (ability to fit in and negotiate interactive aspects of the new culture and one's own culture) (Searle & Ward, 1990).

Perceived Discrimination, Acculturation Attitudes, and Adaptation

Perceived discrimination is the subjective perception or experience of the salience of unfairness in an outcome attributed to prejudice (Schmitt & Branscombe, 2002). It is detrimental to psychological well-being in that it can lead to adverse psychological symptoms, such as low self-esteem, depression, aggression, insecurity, etc. (Britt-Spells et al., 2018; DeWall & Bushman, 2011; Model et al., 2009; Stein et al., 2016). Perceived discrimination can also influence adaptation indirectly through acculturation attitudes (Berry et al., 2006; Berry & Sabatier, 2010; Giuliani et al., 2018; Te Lindert et al., 2008).

Each of Berry's four acculturation attitudes results in a different level of adaptation by the immigrants (Berry, 1997, 2003, 2005; Berry et al., 2006; Berry & Sabatier, 2010; Hashemi et al., 2019; Te Lindert et al., 2008; Ward & Rana-Deuba, 1999). Integration usually results in good sociocultural and psychological adaptation (Bierwiczzonek & Kunst, 2021), while marginalization usually results in poor psychological and sociocultural adaptation. Assimilation can facilitate sociocultural adaptation but may be detrimental to psychological adaptation, while separation can facilitate psychological adaptation but may impede sociocultural adaptation (Berry et al., 2006; Berry & Sabatier, 2010; Guerra, et al., 2019; Ward & Rana-Deuba, 1999). Perceived discrimination typically orients immigrants/ minorities away from participating in the mainstream culture, thus decreasing their likelihood of adopting an integrative or assimilationist attitude while increasing their tendency to adopt a separation or marginalization attitude (Berry et al., 2006; Berry & Sabatier, 2010; Guerra, et al., 2019; Hashemi et al., 2019; Te Lindert et al., 2008).

According to the rejection-identification model, individuals may increase their orientation towards strong ethnic identification under conditions of high perceived discrimination, which can help them maintain psychological well-being in the face of societal devaluation (Branscombe et al., 1999; Hashemi et al., 2019). This explains why perceived discrimination may positively relate to a separation attitude. In addition, social identity theory contends that people's self-image is derived from the group with which they identify, so they are motivated to identify with a positively valued group to preserve a positive self-image (Tajfel & Turner, 1979). When a group's value (esteem) is threatened (*e.g.*, through discrimination), a person may attempt to dis-identify from his or her in-group to protect his or her self-esteem, and become increasingly averse to the source of the threat (*e.g.*, the discriminatory mainstream culture for immigrants/minorities) (Tajfel & Turner, 1986). This explains why perceived discrimination may positively relate to the marginalization attitude.

In accordance with all these theories, what appears clear is that perceived discrimination severely decreases the likelihood that immigrants/ minorities will simultaneously engage in their heritage and the mainstream culture, implying a strong negative association with an integrative attitude. Considering that the integration attitude tends to positively predict both psychological and sociocultural adaptation (Bierwiaczonek & Kunst, 2021), a negative orientation toward integration is likely to result in maladaptation.

Neuroticism as a Moderator in the Relationship between Perceived Discrimination, Acculturation Attitudes, and Adaptation

Neuroticism is characterized by a chronic level of emotional instability and proneness to psychological distress. People with high levels of neuroticism are often insecure in their self-image, anxious, and paranoid. They tend to over-think and exaggerate the significance of their problems, and dwell a lot on the negative aspects of things (McCrae & John, 1992). Neuroticism predicts psychological and sociocultural maladaptation (Bakker et al., 2005; Friedrich & Alvarez, 2020; Ryder et al., 2000; Van der Zee et al., 2016; Van der Zee & Van Oudenhoven, 2013, 2014; Ward et al., 2004). It also has been consistently found to positively predict marginalization attitudes (Friedrich & Alvarez, 2020; Ryder et al., 2000; Schmitz & Berry, 2011).

However, findings on the relationship between neuroticism and integration attitude have been mixed. While Schmitz and Berry (2011) found that neuroticism had a slightly negative but not significant relationship with integration attitudes among immigrants in Germany, Friedrich and Alvarez (2020) found that neuroticism had a slightly positive significant relationship with integration attitudes among Argentine immigrants in Israel. This variation in results suggests that the relationship could be contextual. Perhaps dependent on the level of perceived acculturative stress?

Generally, acculturation can be a stressful phenomenon (Berry, 2006). One of the main acculturative stressors is perceived discrimination. Perceived discrimination is a form of acculturative stress that elicits negative emotions. Given that neuroticism influences one's susceptibility to stress and negative emotions (Gunthert et al., 1999; McCrae & John, 1992), we can expect neuroticism to have a potent interaction with perceived discrimination. Someone with a high level of neuroticism should be more affected by the negative emotions elicited by perceived discrimination, potentially amplifying their reaction to perceived discrimination.

As acknowledged earlier, perceived discrimination mostly orients immigrants or minorities away from participating in or adopting the mainstream culture. However, it doesn't necessarily mean that they will increasingly opt to preserve their heritage culture (separation attitude). Sometimes, they increasingly orient away from both the mainstream and the heritage culture (marginalization attitude) under conditions of perceived discrimination (Berry et al., 2006). Neuroticism is especially relevant in this regard because individuals higher in neuroticism tend to have fragile self-esteem, and be more self-conscious (F. Amirazodi & M. Amirazodi, 2011; McCrae & John, 1992). In this regard, their neuroticism may increase their tendency to dis-identify

with their in-group in order to protect their self-esteem under conditions of perceived discrimination. However, they also tend to be higher in rejection sensitivity (Brookings et al., 2003; Wilhelm et al., 2004) — *i.e.*, the tendency to readily perceive, anxiously expect, and intensely react to cues of rejection (*e.g.*, discrimination) (Downey & Feldman, 1996). Thus, their tendency to overreact to cues of rejection may also intensify their aversion to participating in the mainstream culture, which is the typical reaction to discrimination.

In light of this, we can hypothesize that neuroticism strengthens perceived discrimination's indirect negative association with psychological and sociocultural adaptation, by strengthening perceived discrimination's negative association with integration attitude, as well as its positive association with marginalization attitude.

Current Study

This study aimed to determine the moderating role of neuroticism in the relationship between perceived discrimination, acculturation attitudes, and adaptation of African immigrants in Russia. *Figure 1* shows the theoretical model.

Within the framework of the model, this study tested the following hypotheses.

1. Perceived discrimination is directly associated with adaptation, as well as indirectly through the acculturation attitudes of African immigrants in Russia.
2. Neuroticism moderates the indirect relationship between perceived discrimination and adaptation by directly affecting the relationship between perceived discrimination and acculturation attitudes.

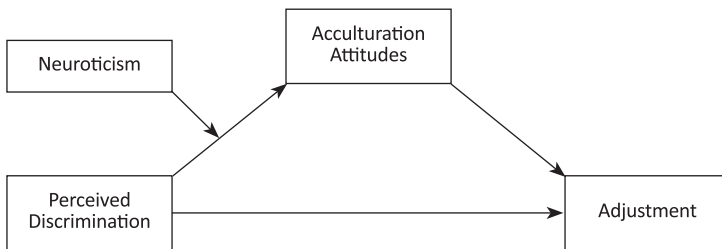

Figure 1. A moderated mediation model for examining the moderating role of neuroticism in the relationship between perceived discrimination, acculturation attitudes, and adaptation

Methods

Participants

The sample consisted of 157 participants from five different Anglophone African countries: Nigeria (78.3%), Ghana (12.7%), Namibia (3.8%), Zambia (2.5%), and Kenya (2.5%). The participants were primarily male (69.4%). The mean age of the sample was 25.27 years ($SD = 4.67$), ranging from 18 years to 55 years. Approximately 60% of the participants had a bachelor's degree; 26.8% a master's degree; 7.6% a doctorate; and 5.7% only a secondary/high school education.

Procedure

The participants were recruited by means of convenience sampling via an online group forum of Anglophone African immigrants in Russia. The members were urged to complete the survey in English. Participation was anonymous and voluntary.

Materials

The responses to the survey questions were scored on a seven-point Likert scale, with answer options ranging from 1 (strongly disagree) to 7 (strongly agree). Confirmatory factor analyses were carried out to test the reliability and validity of the scales for use in the study sample. See the appendix for the list of items for all measures.

Perceived Discrimination. Four (4) items were used to measure perceived discrimination. They were adopted and adapted from the perceived discrimination scale developed by Phinney, Madden, and Santos (1998). Cronbach's alpha was .88 for the study sample. The fit indices were acceptable for the study sample ($\chi^2/df = 1.79$; CFI = .99; RMSEA = .07, PCLOSE = .28).

Neuroticism. Five (5) items were adopted and adapted from the neuroticism subscale of the 120-item IPIP-NEO (International Personality Item Pool [IPIP], n.d.). The fit indices were acceptable for this study sample ($\chi^2/df = 2.03$; CFI = .97; RMSEA = .08, PCLOSE = .20), and the scale was fairly reliable ($\alpha = .70$).

Acculturation Attitudes. We used the four-fold measurement method to assess acculturation attitudes. The instrument used contained sixteen (16) items adopted and adapted from the acculturation attitude scale developed by Kim (2010). The fit indices were acceptable for this study sample ($\chi^2/df = 1.62$; CFI = .89; RMSEA = .07, PCLOSE = .06). These items measure the four acculturation attitudes — *i.e.*, Integration ($\alpha = .68$), separation ($\alpha = .60$), assimilation ($\alpha = .62$), and marginalization ($\alpha = .80$) — across four life domains (*i.e.*, friendship, society, cultural events, and lifestyle). Each attitude is measured with four (4) items, 1 for each life domain.

We discovered that the Cronbach's alphas for the scales integration, separation, and assimilation were rather low. This is most likely because each item measures the participants' cultural orientation in a different life domain. A participant may not adopt the same attitude in every life domain to the same degree. For example, a participant may not adopt separation in the friendship domain as much as they may in the cultural events domain. Thus, Cronbach's alpha is unlikely to be high. The original scales developed by Kim (2010) also reported Cronbach's alpha values in the range of 0.6–0.8 across multiple samples. Nevertheless, the rule of thumb is that 0.6 or above is acceptable for cross-sectional correlational studies (Ursachi et al., 2015). Given that all our scales crossed that threshold, we proceeded to use them for our analysis.

Adaptation. Eight (8) items were used to measure adaptation, adopted and adapted from the Brief Psychological and Sociocultural Adaptation Scale (BPSAS) (Demes & Geeraert, 2014). The fit indices were acceptable for this study sample ($\chi^2/df = 1.88$; CFI = .95; RMSEA = .09, PCLOSE = .03). The BPSAS is made up of two subscales,

namely, the Brief Sociocultural Adaptation Scale (BSAS), and the Brief Psychological Adaptation Scale (BPAS). There were four (4) items from BSAS ($\alpha = .84$), and four (4) items from the BPAS ($\alpha = .60$).

Data Analysis

For the data analysis, we used SPSS and AMOS. To test hypothesis 1, we performed mediation analysis using the SPSS add-on known as *Process-macro*, developed by Andrew Hayes (2017). We used model 4 in *Process-macro* (i.e., a mediation model). To test hypothesis 2, we conducted a moderated mediation analysis also using *Process-macro*. We used model 7 in *Process-macro* (i.e., a moderated mediation model).

Results

Descriptive Statistics of Variables

Table 1 shows the intercorrelations among all variables. Table 2 shows the descriptive statistics for the variables and mean comparisons based on the sample's socio-demographics.

Table 1

Correlations amongst variables (Spearman's correlation)

	1	2	3	4	5	6	7
1. Perceived Discrimination	1						
2. Neuroticism	.19*	1					
3. Integration	-.27**	-.15	1				
4. Assimilation	-.06	.20*	.21**	1			
5. Separation	.21**	.08	-.32**	-.08	1		
6. Marginalization	.22**	.27**	-.41**	.09	.09	1	
7. Sociocultural Adaptation	-.35**	-.28**	.53**	.41**	-.22*	-.18*	1
8. Psychological Adaptation	-.60**	-.28**	.53**	.07	-.15	-.29**	.45**

Note. $N = 157$. ** $p < .01$; * $p < .05$.

In comparing genders through their t-test results, we found that the females ($M = 4.2$, $SD = 1.5$) were higher in neuroticism than the males ($M = 3.5$, $SD = 1.1$), which was significant: $t(155) = -2.8$, $p < .01$. Males ($M = 4.9$, $SD = 1.2$) were also more socio-culturally adapted than females ($M = 4.1$, $SD = 1.3$). The difference was also significant: $t(155) = 3.8$, $p < .001$.

There were no statistically significant differences on any variables, when compared by level of education, length of time spent in Russia, or country of origin (see Table 2).

Table 2

Descriptive statistics of study variables, compared by socio-demographics

	PD	Neu	Intg	Assm	Sepr	Marg	SCA	PA	
Total Sample	3.9	3.7	4.7	3.1	3.9	3.5	4.7	5.1	
[M(SD)]	(1.6)	(1.3)	(1.3)	(1.1)	(1.1)	(1.6)	(1.4)	(1.0)	
Gender	Male M(SD)	3.7	3.5	4.8	3.2	3.8	4.9	5.1	
		(1.5)	(1.1)	(1.1)	(1.1)	(1.1)	(1.4)	(1.2)	
	(.97)								
Female [M(SD)]	4.2	4.2	4.5	3.0	4.1	3.8	4.1	4.9	
	(1.5)	(1.5)	(1.4)	(1.1)	(1.1)	(1.7)	(1.3)	(1.2)	
<i>t</i> (155)	-1.7	-2.8**	1.4	1.0	-1.5	-1.4	3.8***	.65	
Education	High School [M(SD)]	4.2	3.6	4.8	3.1	3.7	3.8	4.0	5.1
		(1.3)	(1.3)	(1.2)	(1.0)	(1.2)	(1.1)	(1.2)	(.40)
	Bachelors [M(SD)]	3.9	3.6	4.8	2.9	3.8	3.4	4.7	5.0
		(1.6)	(1.2)	(1.2)	(1.0)	(1.0)	(1.5)	(1.3)	(1.0)
	Masters [M(SD)]	3.8	3.9	4.4	3.4	3.8	3.7	4.7	5.1
	(1.7)	(1.4)	(1.3)	(1.1)	(1.2)	(1.5)	(1.5)	(1.2)	
Doctorate [M(SD)]	3.5	3.5	4.8	3.4	4.5	3.4	5.3	5.2	
	(1.3)	(1.0)	(1.2)	(1.8)	(1.3)	(1.2)	(.86)	(.97)	
<i>F</i> (3, 153)	.48	1.1	1.8	2.6	1.2	1.1	1.3	.17	
Time in Russia	< 2 yrs [M(SD)]	3.3	3.6	4.9	3.1	3.8	3.3	4.8	5.3
		(1.3)	(1.1)	(1.1)	(1.1)	(.94)	(1.6)	(1.3)	(.87)
	2-4 yrs [M(SD)]	4.0	3.8	4.6	2.9	3.8	3.7	4.3	4.8
		(1.6)	(1.2)	(1.3)	(.86)	(1.0)	(1.7)	(1.1)	(1.1)
	> 4 yrs [M(SD)]	4.0	3.7	4.7	3.3	3.9	3.5	4.8	5.0
	(1.6)	(1.3)	(1.2)	(1.2)	(1.2)	(1.5)	(1.4)	(1.1)	
<i>F</i> (2, 154)	1.9	.13	.49	1.1	.12	.46	1.2	1.6	
Country of Origin	Nigeria [M(SD)]	3.9	3.7	4.7	3.1	3.9	3.5	4.7	5.0
		(1.6)	(1.2)	(1.2)	(1.1)	(1.1)	(1.5)	(1.3)	(1.0)
	Ghana [M(SD)]	3.7	3.9	4.6	3.1	4.0	2.9	5.1	5.1
		(1.7)	(1.3)	(1.5)	(1.0)	(1.2)	(1.4)	(1.4)	(1.0)
	Namibia [M(SD)]	4.2	3.4	5.0	2.4	4.0	2.1	4.1	5.6
		(1.6)	(.72)	(1.5)	(.80)	(1.2)	(1.2)	(.95)	(.61)
	Zambia [M(SD)]	4.6	4.9	4.6	3.4	3.7	3.3	3.9	4.9
	(1.3)	(1.2)	(1.7)	(.66)	(.72)	(2.4)	(.92)	(1.8)	
Kenya [M(SD)]	5.1	4.3	4.6	3.1	3.8	3.8	5.3	4.6	
	(2.6)	(1.6)	(1.8)	(1.2)	(.99)	(1.3)	(1.5)	(1.3)	
<i>F</i> (4, 152)	.92	1.3	.09	.77	.19	1.8	1.4	.67	

Note. *N* = 157. ****p* < .001; ***p* < .01; **p* < .05; PD = Perceived Discrimination; Neu = Neuroticism; Intg = Integration; Assm = Assimilation; Sepr = Separation; Marg = Marginalization; SCA = Socio-cultural Adaptation; PA = Psychological Adaptation.

The Relationship Between Perceived Discrimination, Acculturation Attitudes, and Adaptation

Perceived discrimination had a significantly negative direct association with socio-cultural ($\beta = -.15, p < .01$) and psychological adaptation ($\beta = -.43, p < .01$), after the indirect associations via the acculturation attitudes and other covariates (age, gender, education, length of time spent in Russia, and neuroticism) were accounted for (see Table 3).

Table 3
Multiple regression analysis predicting adaptation of African immigrants in Russia

	Sociocultural Adaptation				Psychological Adaptation			
	R ²	B	SE	β	R ²	B	SE	β
	.50**				.58**			
Perceived Discrimination		-.12**	.05	-.15**		-.28**	.04	-.43**
Integration Attitude		.39**	.08	.38**		.37**	.06	.45**
Assimilation Attitude		.40**	.08	.34**		.01	.06	.01
Separation Attitude		.01	.08	.01		.15*	.06	.16*
Marginalization Attitude		.02	.06	.02		-.02	.04	-.02
Neuroticism		-.21**	.07	-.20**		-.18**	.05	-.21**
Time in Russia		.03	.04	.06		-.01	.03	-.02
Gender (Female)		-.49**	.18	-.17**		.23	.13	.10
Level of Education		.25*	.13	.14*		.15	.09	.10
Age		-.02	.02	-.06		-.02	.01	-.07

Note. N = 157. **p < .01; *p < .05.

Table 4
Indirect Association of Perceived Discrimination with Adaptation

	Sociocultural Adaptation				Psychological Adaptation			
	β	SE	LLCI	ULCI	β	SE	LLCI	ULCI
Integration	-.10	.04	-.19	-.03	-.13	.04	-.22	-.05
Separation	.00	.01	-.03	.03	.03	.02	.00	.08
Assimilation	-.03	.03	-.09	.01	.00	.01	-.02	.02
Marginalization	.01	.02	-.02	.04	.00	.01	-.03	.02

Note. No. of bootstrap samples for percentile bootstrap confidence interval (CI) = 5000; 95% confidence for all CIs.

Table 4 shows the indirect associations of perceived discrimination with adaptation via the person’s acculturation attitudes, after controlling for age, gender, length of time spent in Russia, and neuroticism. We found that perceived discrimination had a significantly negative indirect association via integration attitude with both sociocultural adaptation ($\beta = -.10, SE = .04, LLCI = -.19, ULCI = -.03$) and psychological adaptation ($\beta = -.13, SE = .04, LLCI = -.22, ULCI = -.05$). None of the other acculturation attitudes were significant partial mediators.

Figure 2 shows the partial mediation model, depicting integration attitude as the mediator. It had an acceptable fit ($\chi^2/df = 4.13; CFI = .98; RMSEA = .14, PCLOSE = .08$).

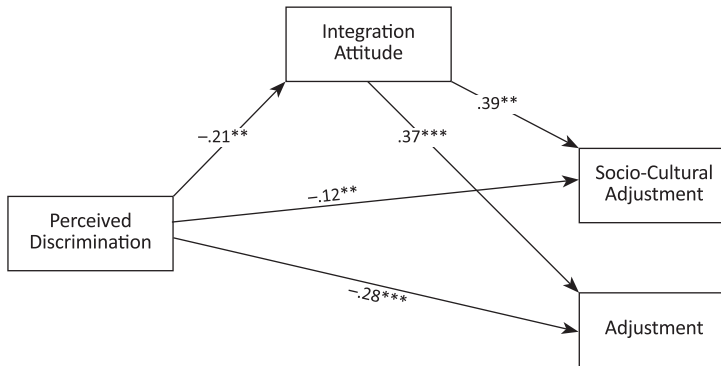

Figure 2. Relationship between Perceived Discrimination, Integration Attitude, and Adaptation

Table 5

Multiple Regression Analysis Predicting Acculturation Attitudes of African Immigrants in Russia

	Integration			Assimilation			Separation			Marginalization		
	ΔR^2	B	SE	ΔR^2	B	SE	ΔR^2	B	SE	ΔR^2	B	SE
Model Sum.	.21			.18			.07			.14		
Age		.05	.02		.08**	.02		.01	.02		-.01	.03
Gender (female)		-.09	.21		-.31	.19		.11	.20		.21	.27
Time in Russia		.02	.04		-.01	.04		-.03	.04		-.02	.06
Education		-.44*	.15		.01	.13		.21	.14		.18	.19
Perceived Discrimination		-.21**	.06		-.07	.05		.15**	.06		.17*	.08
Neuroticism		-.10	.08		.25**	.07		.05	.08		.27**	.11
PD * Neuroticism		.03			-.02	.04		.01	-.05	.04	.01	.07

Note. N = 157. **p < .01; *p < .05.

The Moderating Role of Neuroticism in the Relationship Between Perceived Discrimination, Acculturation Attitudes, and Adaptation

After controlling for the effects of age, gender, education, length of stay in Russia, neuroticism, and perceived discrimination, the results of a series of multiple regression analyses measuring the interaction of perceived discrimination with neuroticism in predicting the acculturation attitudes (see *Table 5*), showed that it was significant in predicting integration attitude ($\beta = -.12, p < .05$), but not marginalization ($\beta = .07, p = .22$), assimilation ($\beta = -.02, p = .65$), or separation ($\beta = .01, p = .28$).

Figure 3 presents the predicted values for the interaction between perceived discrimination and neuroticism in predicting integration attitude.

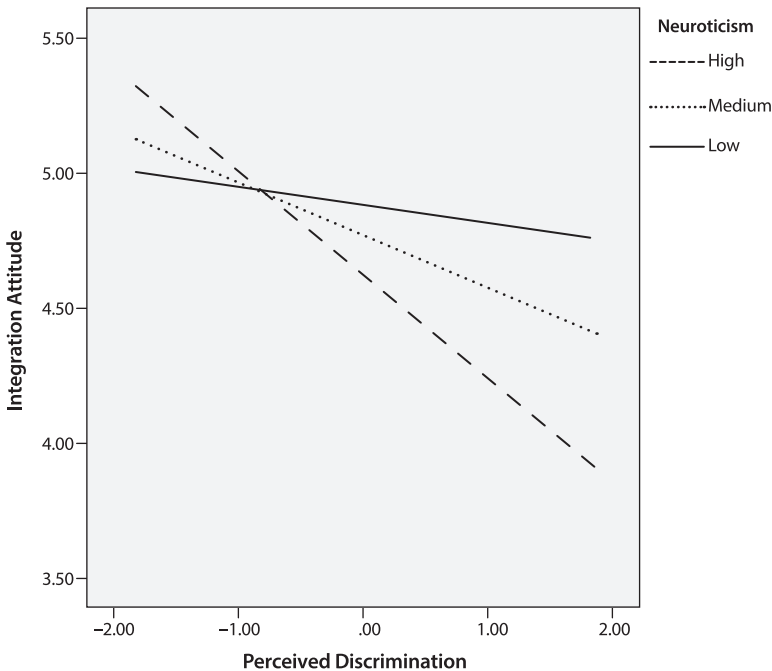

Figure 3. Predicted values of integration attitude, illustrating the interaction between perceived discrimination and neuroticism

Comparison of the slopes of the regression lines representing low (16th percentile: $B = -.06, SE = .09, p = .47$), medium (50th percentile: $B = -.20, SE = .06, p < .01$), and high neuroticism (84th percentile: $B = -.38, SE = .09, p < .001$) indicated that the negative association between perceived discrimination and integration attitude was stronger when the participants were higher in neuroticism.

The results of the moderated mediation showed that neuroticism moderated the indirect relationship between perceived discrimination and both sociocultural ($B = -.05, SE = .02, LLCI = -.10, ULCI = -.01$) and psychological adaptation ($B = -.05, SE = .02, LLCI = -.09, ULCI = -.01$), via integration attitude.

Comparison of the indirect effect of perceived discrimination on sociocultural adaptation via integration attitude at low ($B = -.03, SE = .04, LLCI = -.11, ULCI = .05$),

medium ($B = -.08$, $SE = .03$, $LLCI = -.15$, $ULCI = -.03$), and high levels of neuroticism ($B = -.16$, $SE = .05$, $LLCI = -.28$, $ULCI = -.07$) indicated that the negative indirect association between perceived discrimination and sociocultural adaptation, via integration attitude was stronger when the participants were higher in neuroticism. The same was the case for psychological adaptation: Low ($B = -.02$, $SE = .04$, $LLCI = -.10$, $ULCI = .05$), medium ($B = -.08$, $SE = .03$, $LLCI = -.14$, $ULCI = -.02$), and high neuroticism ($B = -.15$, $SE = .05$, $LLCI = -.25$, $ULCI = -.07$).

Discussion

The goal of this study was to determine the moderating role of neuroticism in the relationship between perceived discrimination, acculturation attitudes, and adaptation (sociocultural and psychological) of African immigrants in Russia.

Perceived discrimination has been previously found to predict psychological and sociocultural maladaptation, directly and indirectly through the acculturation attitudes (Giuliani et al., 2018; Te Lindert et al., 2008). Our results supported this claim. We found that perceived discrimination had a direct negative association with both psychological and sociocultural adaptation.

Perceived discrimination may be directly detrimental to psychological well-being in the sense that it can trigger a feeling of rejection (Model et al, 2009). According to social rejection theory, feeling rejected can lead to adverse psychological symptoms, such as low self-esteem, depression, aggression, insecurity, etc. (DeWall & Bushman, 2011; Model et al, 2009). Perceived discrimination may also indirectly predict psychological and sociocultural maladaptation in the sense that it can influence how immigrants/minorities decide to acculturate (*i.e.*, their acculturation attitudes), and this decision can impact their level of adaptation.

According to the existing evidence, immigrants/minorities are less likely to adopt a positive attitude toward integration when they perceive higher levels of discrimination (Berry et al., 2006; Giuliani et al., 2018; Te Lindert et al., 2008). The consequence of this is that their psychological and sociocultural adaptation may suffer, given that integration attitude has repeatedly been demonstrated to positively predict adaptation to varying degrees (Berry et al., 2006; Te Lindert et al., 2008; Bierwiazzonek & Kunst, 2021).

We found support for this assertion. Our results showed that perceived discrimination is negatively associated with integration attitude, which then leads to sociocultural and psychological maladaptation. In other words, the negative associations of perceived discrimination with both psychological and sociocultural adaptation were partially mediated by integration attitude.

In essence, as the levels of perceived discrimination of African immigrants in Russia increased, the immigrants increasingly veered away from adopting an integration attitude (*i.e.*, not inclined to preserving their heritage culture and participating in the mainstream culture simultaneously): this led to them to be less adapted psychologically and socioculturally. Perceived discrimination may negatively predict integration attitude in the sense that perceived discrimination is seen as a threat to a group's esteem/value. According to the theory of group esteem threat, when people

feel that the value of their in-group is threatened (*e.g.*, via discrimination), they may try to dis-identify from it in order to protect their self-esteem, while simultaneously becoming increasingly averse toward the source of the threat (*e.g.*, the discriminatory host society for immigrants/minorities) (Tajfel & Turner, 1986).

Based on the nature-nurture paradigm in psychology, we understand that dispositional factors interact with social/environmental factors to determine a certain outcome. Thus, when dealing with humans, we can expect individual differences in reactions to similar sociocultural conditions due to differences in personality characteristics. With the knowledge that perceived discrimination is an acculturative stressor that elicits negative emotions and psychological distress (Berry, 2006; DeWall & Bushman, 2011; Model et al, 2009; Stein et al, 2016), we wanted to see whether neuroticism interacts with perceived discrimination to influence acculturation attitudes, and how this might affect adaptation. In other words, does the level of neuroticism of African immigrants in Russia influence how they react to perceived discrimination in terms of how they decide to acculturate (acculturation attitude) under these conditions? And does this consequently impact their level of adaptation?

Emotional reactivity, a component of neuroticism, is known to intensify the direct positive relationship between perceived discrimination and depressive symptoms (Stein et al., 2016). However, there is still a gap in knowledge about how neuroticism interacts with perceived discrimination to predict the acculturation attitudes, which indirectly impact adaptation. This study sought to fill this gap by investigating the moderating role of neuroticism in the indirect relationship between perceived discrimination and adaptation via the acculturation attitudes of African immigrants in Russia.

The results showed that neuroticism strengthened the negative relationship between perceived discrimination and integration attitude, thereby indirectly strengthening its detrimental effect on adaptation (both psychological and sociocultural). At higher levels of perceived discrimination, African immigrants higher in neuroticism were significantly less likely to adopt an integration attitude compared to those lower in neuroticism. Thus, even despite perceiving similarly high levels of discrimination, those higher in neuroticism were significantly more maladapted psychologically and socioculturally than those lower in neuroticism.

Neuroticism is characterized by a higher proclivity for psychological distress caused by negative emotions and stress (Gunthert et al., 1999; McCrae & John, 1992; Steenhaut et al., 2018), as well as an increased sensitivity to rejection. (Brookings et al., 2003; Wilhelm et al., 2004). Given that perceived discrimination is a form of acculturative stress (Berry, 2006) and a form of rejection that elicits negative emotions and causes psychological distress (*e.g.*, low self-esteem, depression, aggression, insecurity, and so on), it's highly probable that African immigrants higher in neuroticism were more affected by the negative emotions and psychological distress elicited by perceiving higher levels of discrimination. And since they also tend to be relatively higher in sensitivity to rejection, they had a stronger reaction, veering away from adopting an integration attitude at a significantly higher rate than those lower in neuroticism. As a consequence of this, those higher in neuroticism were less psychologically and socio-culturally adapted to life in Russia.

Conclusion

In their research on sociocultural adaptation of Africans in Russia, Bondarenko et al. (2009) conducted interviews with some African immigrants on their experiences of living in Russia. They found that most of them, including those who had a relatively good command of the Russian language, shared experiences of discrimination and appeared to be psychologically and socio-culturally maladapted to the Russian society. However, there are reports of cases where, despite being under similar conditions of perceived discrimination, some African immigrants were relatively well adapted in Russian society (Simmons, 2014). Thus, in this study, we sought to investigate whether the personality trait of neuroticism could somewhat account for this variation by moderating the relationship between perceived discrimination, acculturation attitudes, and adaptation.

The results of our analysis indicated that neuroticism was a significant moderator in the relationship between perceived discrimination, integration attitude, and adaptation. Specifically, we found that, compared to neurotic African immigrants, those who were emotionally stable did not significantly veer away from adopting an integration attitude, even under similarly high levels of perceived discrimination. This consequently led to them being less impacted by the indirect negative effects of perceived discrimination on their psychological and sociocultural adaptation. Considering that neuroticism makes one more prone to experiencing negative emotions and psychological distress (Costa & McCrae, 1985), we extrapolated that the African immigrants higher in neuroticism might have been more impacted by the negative emotions and psychological distress elicited by perceived discrimination. This could explain why they had a stronger negative reaction toward integration.

Future studies could investigate how different personality traits could interact with each other to moderate the relationship between perceived discrimination and acculturation orientations. For example, considering that extraverts are in their comfort zone when being outgoing, sociable, and gregarious, they may not be as likely as introverts are to withdraw from participation in the mainstream culture, even under conditions of perceived discrimination. In this sense, an extrovert with a high level of neuroticism may find it even more difficult to disengage from involvement with the mainstream culture, as his/her neuroticism might exacerbate the distress under conditions of social withdrawal. This could indicate that extraversion would mitigate neuroticism's moderating influence in the relationship between perceived discrimination and acculturation orientations.

Limitations

It is important to note some of the limitations of this study. First, due to its cross-sectional design, we cannot conclude causality. Secondly, the sample size was only suitable (at a power of .8) for detecting moderate effects in regression. Thus, there is a risk of a type 2 error since significant smaller effects may have been missed.

Despite some of the limitations of this study, its findings provide a plausible partial explanation as to why some African immigrants in Russia, under similar conditions of high perceived discrimination, were relatively well-integrated and adapted compared to others. This may have been a result of their lower levels of neuroticism.

Ethics Statement

The procedure was carried out in accordance with the American Psychological Association's (APA) Ethical Principles of Psychologists and Code of Conduct as revised in 2017 (American Psychological Association [APA], 2017); participants were given a brief description of the study; informed of their right to terminate participation at any time for any reason; guaranteed anonymity as no identifying information was collected; were informed of the estimated duration of study; and then were required to give their consent to voluntary participation by checking an informed consent box before proceeding to participate. Participants were limited to 18-year-olds and older.

Author Contributions

S.K. Ivande and T. Ryabinchenko conceived of the idea. S.K. Ivande developed the theory, and performed the computations and data analysis, primarily as part of the realization of his master's thesis. T. Ryabinchenko provided ample feedback and guidance in the capacity of a supervisor. Both authors discussed the results and contributed to the final manuscript.

Acknowledgements

The study was part of S.K. Ivande's thesis for his Masters degree at the HSE University, Moscow, Russia, received under the state-funded quota (tuition waiver by the Russian Government). T. Ryabinchenko's role as his academic supervisor was funded by the HSE University, Moscow, Russia. No dedicated monetary funds were received to conduct this research.

Conflict of Interest

The authors declare no conflict of interest.

References

- Allina-Pisano, J., & Allina-Pisano, E. (2007). Friendship of People after the Fall: Violence and Pan-African Community in Post-Soviet Moscow. In M. Matusевич (Ed.), *Africa in Russia, Russia in Africa: Three Centuries of Encounters* (pp. 175–98). Trenton, NJ: Africa World Press. <https://doi.org/10.4000/etudesafricaines.20776>
- American Psychological Association. (2017). *Ethical Principles of Psychologists and Code of Conduct*. American Psychological Association. Retrieved from <https://www.apa.org/ethics/code>
- Amirazodi, F., & Amirazodi, M. (2011). Personality traits and self-esteem. *Procedia-Social and Behavioral Sciences*, 29, 713–716. <https://doi.org/10.1016/j.sbspro.2011.11.296>
- Arends-Toth, J., & van de Vijver, F.R. (2006). Assessment of psychological acculturation. *PsycINFO Database Record (c) 2012 APA*. <https://doi.org/10.1017/CBO9780511489891.013>
- Bakker, W., Van Oudenhoven, J.P., & Van der Zee, K.I. (2004). Attachment and emigrants' intercultural adaptation. *European Journal of Personality*, 18, 387–404. <https://doi.org/10.1002/per.515>
- Berry, J.W. (1997). Immigration, acculturation, and adaptation. *Applied Psychology*, 46(1), 5–34. <https://doi.org/10.1111/j.1464-0597.1997.tb01087.x>
- Berry, J.W. (2003). Conceptual approaches to acculturation. *Acculturation: Advances in Theory, Measurement, and Applied Research*, 17–37. <https://doi.org/10.1037/10472-004>
- Berry, J.W. (2005). Acculturation: Living successfully in two cultures. *International Journal of Intercultural Relations*, 29(6), 697–712. <https://doi.org/10.1016/j.ijintrel.2005.07.013>

- Berry, J.W. (2006). Acculturative stress. In *Handbook of Multicultural Perspectives on Stress and Coping* (pp. 287–298). Springer, Boston, MA. https://doi.org/10.1007/0-387-26238-5_12
- Berry, J.W., Kim, U., Power, S., Young, M., & Bujaki, M. (1989). Acculturation attitudes in plural societies. *Applied Psychology, 38*(2), 185–206. <https://doi.org/10.1111/j.1464-0597.1989.tb01208.x>
- Berry, J.W., Phinney, J.S., Sam, D.L., & Vedder, P.E. (Eds.). (2006). *Immigrant youth in cultural transition: Acculturation, identity, and adaptation across national contexts* (1st ed.). Psychology Press. <https://doi.org/10.4324/9780415963619>
- Berry, J.W., & Sabatier, C. (2010). Acculturation, discrimination, and adaptation among second generation immigrant youth in Montreal and Paris. *International Journal of Intercultural Relations, 34*(3), 191–207. <https://doi.org/10.1016/j.ijintrel.2009.11.007>
- Bierwaczonok, K., & Kunst, J.R. (2021). Revisiting the integration hypothesis: Correlational and longitudinal meta-analyses demonstrate the limited role of acculturation for cross-cultural adaptation. *Psychological Science, 32*(9), 1476–1493. <https://doi.org/10.1177/09567976211006432>
- Boltovskaja, S. (2010). African Communities in Moscow and St. Petersburg – Issues of Inclusion and Exclusion. In C. Gdaniec (Ed.), *Cultural Diversity in Russian Cities: The Urban Landscape in the Post-Soviet Era* (pp. 94–114). London: Berghahn Books. Retrieved from <https://www.jstor.org/stable/j.ctt9qd2ph>
- Bondarenko, D.M. (2017). African Migrants in Post-Soviet Moscow: Adaptation and Integration in a Time of Radical Socio-Political Transformations. *Journal of African Migration, (9)*, 34. <https://doi.org/10.13140/2.1.1643.1048>
- Bondarenko, D.M., Gogueva, E.A., Serov, S.N., & Shakhbazyan, E.V. (2009). Post-socialism Meets Postcolonialism: African Migrants in the Russian Capital. *Anthropological Journal of European Cultures, 18*(2), 87–105. <https://doi.org/10.3167/ajec.2009.180206>
- Branscombe, N.R., Schmitt, M.T., & Harvey, R.D. (1999). Perceiving pervasive discrimination among African Americans: Implications for group identification and well-being. *Journal of Personality and Social Psychology, 77*(1), 135. <https://doi.org/10.1037/0022-3514.77.1.135>
- Britt-Spells, A.M., Slebodnik, M., Sands, L.P., & Rollock, D. (2018). Effects of perceived discrimination on depressive symptoms among Black men residing in the United States: A meta-analysis. *American Journal of Men's Health, 12*(1), 52–63. <https://doi.org/10.1177/1557988315624509>
- Brookings, J.B., Zembar, M.J., & Hochstetler, G.M. (2003). An interpersonal circumplex/five-factor analysis of the Rejection Sensitivity Questionnaire. *Personality and Individual Differences, 34*, 449–461. [https://doi.org/10.1016/S0191-8869\(02\)00065-X](https://doi.org/10.1016/S0191-8869(02)00065-X)
- Demes, K.A., & Geeraert, N. (2014). Measures matter: Scales for adaptation, cultural distance, and acculturation orientation revisited. *Journal of Cross-Cultural Psychology, 45*(1), 91–109. <https://doi.org/10.1177/0022022113487590>
- DeWall, C.N., & Bushman, B.J. (2011). Social acceptance and rejection: The sweet and the bitter. *Current Directions in Psychological Science, 20*(4), 256–260. <https://doi.org/10.1177/0963721411417545>
- Downey, G., & Feldman, S.I. (1996). Implications of rejection sensitivity for intimate relationships. *Journal of Personality and Social Psychology, 70*(6), 1327. <https://doi.org/10.1037/0022-3514.70.6.1327>
- Fidan, H., & Aras, B. (2010). The return of Russia-Africa relations. *Bilig*. Retrieved from <http://bilig.yesevi.edu.tr/yonetim/icerik/makaleler/2690-published.pdf>
- Friedrich, M., & Alvarez, F.P. (2020). Acculturation in Jewish Argentines Migrating to Israel. *PSO-CIAL, 6*(1), 38–50.
- Giuliani, C., Tagliabue, S., & Regalia, C. (2018). Psychological well-being, multiple identities, and discrimination among first- and second-generation immigrant Muslims. *Europe's Journal of Psychology, 14*(1), 66. <https://doi.org/10.5964/ejop.v14i1.1434>
- Gribanova, L. (2009). Deti-metisii v Rossii: svoi sredi chuzhikh [Mestizo children in Russia: friends among strangers]. Retrieved on June 19 from <https://fundmetis.ru/stati/post/deti-metisy-v-rossii-svoi-sredi-chuzhikh>
- Guerra, R., Rodrigues, R.B., Aguiar, C., Carmona, M., Alexandre, J., & Lopes, R.C. (2019). School achievement and well-being of immigrant children: The role of acculturation orientations and perceived discrimination. *Journal of School Psychology, 75*, 104–118. <https://doi.org/10.1016/j.jsp.2019.07.004>

- Güler, A., & Yıldırım, M. (2022). Associations between acculturation, perceived discrimination and subjective well-being among Syrian adolescents living in Turkey. *International Journal of Psychology*, 57(2), 171–180. <https://doi.org/10.1002/ijop.12795>
- Gunther, K.C., Cohen, L.H., & Armeli, S. (1999). The role of neuroticism in daily stress and coping. *Journal of Personality and Social Psychology*, 77(5), 1087. <https://doi.org/10.1037/0022-3514.77.5.1087>
- Hashemi, N., Marzban, M., Sebar, B., & Harris, N. (2019). Acculturation and psychological well-being among Middle Eastern migrants in Australia: The mediating role of social support and perceived discrimination. *International Journal of Intercultural Relations*, 72, 45–60. <https://doi.org/10.1016/j.ijintrel.2019.07.002>
- Hasan, S.I., Yee, A., Rinaldi, A., Azham, A.A., Mohd Hairi, F., & Amer Nordin, A.S. (2021). Prevalence of common mental health issues among migrant workers: A systematic review and meta-analysis. *PLoS one*, 16(12), e0260221. <https://doi.org/10.1371/journal.pone.0260221>
- Hayes, A.F. (2017). *Introduction to mediation, moderation, and conditional process analysis: A regression-based approach*. Guilford publications.
- Huang, T., Chi, S., & Lawler, J.J. (2005). The relationship between expatriates' personality traits and their adaptation to international assignments. *International Journal of Human Resource Management*, 16, 1656–1670. <https://doi.org/10.1080/09585190500239325>
- International Personality Item Pool. (n.d.). Short Form for the IPIP-NEO (International Personality Item Pool Representation of the NEO PI-R). Retrieved on August 16, 2020, from <http://www.personal.psu.edu/~j5j/IPIP/ipipneo120.htm>
- Jasinskaja-Lahti, I., & Liebkind, K. (2001). Perceived discrimination and psychological adaptation among Russian-speaking immigrant adolescents in Finland. *International Journal of Psychology*, 36(3), 174–185. <https://doi.org/10.1080/00207590042000074>
- Kim, U. (2010). *Acculturation attitudes scale: Development and validation of the scale with Korean and Korean-Canadian samples*. [Paper presentation] Indonesian Psychological Association Conference, Solo, Indonesia. Retrieved from https://www.researchgate.net/publication/309722447_Acculturation_Attributes_Scale_Development_and_Validation_of_the_Scale_with_Korean_and_Korean-Canadian_Samples
- Kulis, S., Marsiglia, F.F., & Nieri, T. (2009). Perceived ethnic discrimination versus acculturation stress: Influences on substance use among Latino youth in the Southwest. *Journal of Health and Social Behavior*, 50(4), 443–459. <https://doi.org/10.1177/002214650905000405>
- Kvernmø, S., & Heyerdahl, S. (2004). Ethnic identity and acculturation attitudes among indigenous Norwegian Sami and ethnocultural Kven adolescents. *Journal of Adolescent Research*, 19(5), 512–532. <https://doi.org/10.1177/0743558403259991>
- McCrae, R.R., & John, O.P. (1992). An introduction to the Five-Factor Model and its applications. *Journal of Personality*, 60, 175–215. <https://doi.org/10.1111/j.1467-6494.1992.tb00970.x>
- Model, A.M., Richman, L.S., & Leary, M.R. (2009). Reactions to discrimination, stigmatization, ostracism, and other forms of interpersonal rejection. *Psychol. Rev.*, 116(2), 365–383. <https://doi.org/10.1037/a0015250>
- Noh, S., & Kaspar, V. (2003). Perceived discrimination and depression: Moderating effects of coping, acculturation, and ethnic support. *American Journal of Public Health*, 93(2), 232–238. <https://doi.org/10.2105/AJPH.93.2.232>
- Phinney, J.S., Madden, T., & Santos, L.J. (1998). Psychological variables as predictors of perceived ethnic discrimination among minority and immigrant adolescents 1. *Journal of Applied Social Psychology*, 28(11), 937–953. <https://doi.org/10.1111/j.1559-1816.1998.tb01661.x>
- Robinson, L. (2005). South Asians in Britain: acculturation, identity and perceived discrimination. *Psychology and Developing Societies*, 17(2), 181–194. <https://doi.org/10.1177/097133360501700206>
- Ryder, A.G., Alden, L.E., & Paulhus, D.L. (2000). Is acculturation unidimensional or bidimensional? A head-to-head comparison in the prediction of personality, self-identity, and adaptation. *Journal of Personality and Social Psychology*, 79(1), 49. <https://doi.org/10.1037/0022-3514.79.1.49>
- Schmitz, P., & Berry, J.W. (2011). Structure of acculturation attitudes and their relationships with personality and psychological adaptation: A study with immigrant and national samples in Germany. In K. Boehnke (Ed.). *Proceedings of IACCP Congress (online)*. Retrieved from https://scholarworks.gvsu.edu/iaccp_papers/80

- Searle, W., & Ward, C. (1990). The prediction of psychological and sociocultural adaptation during cross-cultural transitions. *International Journal of Intercultural Relations*, 14(4), 449–464. [https://doi.org/10.1016/0147-1767\(90\)90030-Z](https://doi.org/10.1016/0147-1767(90)90030-Z)
- Simmons, A.M. (2014, November 2). *African migrants in Russia describe 'hell on Earth'*. Los Angeles Times. <https://www.latimes.com/world/africa/la-fg-russia-africans-20141102-story.html>
- Steenhaut, P., Demeyer, I., De Raedt, R., & Rossi, G. (2018). The role of personality in the assessment of subjective and physiological emotional reactivity: a comparison between younger and older adults. *Assessment*, 25(3), 285–301. <https://doi.org/10.1177/1073191117719510>
- Stein, G.L., Supple, A.J., Huq, N., Dunbar, A.S., & Prinstein, M.J. (2016). A longitudinal examination of perceived discrimination and depressive symptoms in ethnic minority youth: The roles of attributional style, positive ethnic/racial affect, and emotional reactivity. *Developmental Psychology*, 52(2), 259. <https://doi.org/10.1037/a0039902>
- Tajfel, H., & Turner, J.C. (1979). An integrative theory of intergroup conflict. In W.G. Austin & S. Worchel (Eds.), *The social psychology of intergroup relations* (pp. 33–47). Monterrey, CA: Brooks-Cole. Retrieved from [https://www.scirp.org/\(S\(351jmbntvnsjt1aadkposzje\)\)/reference/References-Papers.aspx?ReferenceID=757561](https://www.scirp.org/(S(351jmbntvnsjt1aadkposzje))/reference/References-Papers.aspx?ReferenceID=757561)
- Tajfel, H., & Turner, J.C. (1986). The social identity theory of intergroup behavior. In S. Worchel & W.G. Austin (Eds.), *Psychology of intergroup relations* (2nd ed.) (pp. 7–24). Chicago: Nelson-Hall. Retrieved from [https://www.scirp.org/\(S\(351jmbntvnsjt1aadkposzje\)\)/reference/References-Papers.aspx?ReferenceID=1584694](https://www.scirp.org/(S(351jmbntvnsjt1aadkposzje))/reference/References-Papers.aspx?ReferenceID=1584694)
- Te Lindert, A., Korzilius, H., Van de Vijver, F.J., Kroon, S., & Arends-Tóth, J. (2008). Perceived discrimination and acculturation among Iranian refugees in the Netherlands. *International Journal of Intercultural Relations*, 32(6), 578–588. <https://doi.org/10.1016/j.ijintrel.2008.09.003>
- Ursachi, G., Horodnic, I.A., & Zait, A. (2015). How reliable are measurement scales? External factors with indirect influence on reliability estimators. *Procedia Economics and Finance*, 20, 679–686. [https://doi.org/10.1016/s2212-5671\(15\)00123-9](https://doi.org/10.1016/s2212-5671(15)00123-9)
- Van der Zee, K., Benet-Martínez, V., & Van Oudenhoven, J.P. (2016). Personality and acculturation. *The Cambridge Handbook of Acculturation Psychology*, 5070. <https://doi.org/10.1017/CBO9781316219218.005>
- Van der Zee, K.I., & Van Oudenhoven, J.P. (2013). Culture shock challenge? The role of personality as a determinant of intercultural competence. *Journal of Cross-Cultural Psychology*, 44, 928–940. <https://doi.org/10.1177/0022022113493138>
- Van der Zee, K.I., & Van Oudenhoven, J.P. (2014). Personality and multicultural effectiveness. In V. Benet-Martínez & Y.Y. Hong (Eds.), *The Oxford Handbook of Multicultural Identity* (pp. 255–275). New York, NY: Oxford University Press. <https://doi.org/10.1093/oxfordhb/9780199796694.013.008>
- Ward, C., Leong, C., & Low, M. (2004). Personality and sojourner adaptation: An exploration of the Big Five and the cultural fit proposition. *Journal of Cross-Cultural Psychology*, 35, 137–151. <https://doi.org/10.1177/0022022103260719>
- Ward, C., & Rana-Deuba, A. (1999). Acculturation and adaptation revisited. *Journal of Cross-cultural Psychology*, 30(4), 422–442. <https://doi.org/10.1177/0022022199030004003>
- Wilhelm, K., Boyce, P., & Brownhill, S. (2004). The relationship between interpersonal sensitivity, anxiety disorders and major depression. *Journal of Affective Disorders*, 79, 33–41. [https://doi.org/10.1016/S0165-0327\(02\)00069-1](https://doi.org/10.1016/S0165-0327(02)00069-1)

Original manuscript received August 15, 2021

Revised manuscript accepted January 25, 2023

First published online March 30, 2023

To cite this article: Ivande, S.K., Ryabinchenko, T. (2023). The Relationship Between Perceived Discrimination, Acculturation Attitudes, and Adaptation among Anglophone African Immigrants in Russia: The Moderating Role of Neuroticism. *Psychology in Russia: State of the Art*, 16(1), 77–97. DOI: 10.11621/pir.2023.0105

Appendix

Questionnaire items

Note: All answers except those on socio-demographics are measured with a 7-point Likert scale (1 = *Strongly Disagree*; 7 = *Strongly Agree*); * Reversed item.

Socio-demographics

1. Age (input)
2. Gender (male, female, other)
3. Country of Origin (input)
4. Level of Education (no education, primary, secondary/high school, bachelors, masters, doctorate)
5. Length of Time in Russia (< 6 mths, 6 mths – 1 yr., 1-1.5yrs, 1.5-2 yrs. >4 yrs.)

Neuroticism

Instruction: Indicate your level of agreement with the following about yourself currently, not how you wish to be in the future.

- i. I seldom feel blue.
- ii. Most of the time I am relaxed; I handle stress well. *
- iii. I am easily upset.
- iv. I often feel anxious about what could go wrong.
- v. I have frequent mood swings.

Perceived Discrimination Scale

Instruction: Indicate your level of agreement with the following about your experience in Russia.

1. I feel as if I am ignored or excluded from opportunities such as good jobs in Russia because I am African.
2. In general, I feel as if Russians view Africans in a negative way and act unfairly towards us.
3. I feel as if I am not wanted, accepted, or welcomed in Russia because I am African.
4. I don't quite feel valued or respected by my Russian colleagues at school or work because I am African.

Acculturation attitude

Instruction: Indicate your level of agreement with the following about your experience in Russia.

1. **Friendship domain.**
 - i. *Assimilation:* I find myself a lot more inclined toward having Russian friends than I am toward having African friends.
 - ii. *Separation:* I find myself a lot more inclined toward having African friends than I am toward having Russian friends.
 - iii. *Integration:* I find that I have a balanced inclination toward having Russian and African friends.
 - iv. *Marginalization:* I don't really have an inclination toward having either Russian or African friends. These days, it's hard to find someone I can really relate to.

2. Society domain.

- i. *Assimilation*: Encouraging Africans to stick together and unequivocally practice our culture in Russia only hinders our acceptance into Russian society.
- ii. *Separation*: Because we live in Russia, we are losing our heritage to the Russian culture. Thus, I decide to emphasize my distinct African identity and minimize my participation in the Russian culture.
- iii. *Integration*: While living in Russia, I strive to retain my African cultural heritage and lifestyle, while also participating fully in various aspects of Russian culture.
- iv. *Marginalization*: I don't really care about preserving my African cultural heritage nor participating in the Russian culture.

3. Events domain.

- i. *Assimilation*: I tend to value attending Russian events like parties, ceremonies, etc. significantly more than I value attending African events in Russia.
- ii. *Separation*: I value attending African events in Russia significantly more than I value Russian events.
- iii. *Integration*: I value attending African events in Russia as well as Russian events more or less equally.
- iv. *Marginalization*: Neither African events nor Russian events hold much value for me. I just don't care very much about either of them.

4. Lifestyle domain.

- i. *Assimilation*: I have more of a Russian lifestyle than my African cultural heritage lifestyle now that I am living in Russia.
- ii. *Separation*: My lifestyle is nothing like that of the Russians. I try to maintain my African cultural lifestyle as much as I can.
- iii. *Integration*: My lifestyle in Russia is a substantial blend between my African cultural heritage and the Russian lifestyle.
- iv. *Marginalization*: I don't live according to either my African cultural heritage or the Russian lifestyle. I live in my unique way.

Sociocultural adaptation scale

1. I find it easy to make Russian friends.
2. I get along easily with Russians.
3. I have a relatively good understanding of the social norms in Russia, e.g., what is appropriate to say, how to act, dress, etc.
4. I find it easy to make myself understood by and to understand Russian people.

Psychological adaptation scale

1. I am happy with my day-to-day life in Russia.
2. I feel out of place, as if I don't fit in, living in Russia. *
3. I feel uncomfortable being around Russians. *
4. I feel a sense of freedom living in Russia.

Exploring the Associations between Happiness, Life-satisfaction, Anxiety, and Emotional Regulation among Adults during the Early Stage of the COVID-19 Pandemic in Russia

Dmitriy S. Kornienko^{a*}, Natalya A. Rudnova^b

^a *Russian Presidential Academy of National Economy & Public Administration, Moscow, Russia*

^b *Psychological Institute of the Russian Academy of Education, Moscow, Russia*

*Corresponding author. E-mail: dscorney@gmail.com

Background. The COVID-19 pandemic is not only a world health crisis, but also an ordeal for people's mental health and psychological well-being. The period of the COVID-19 lockdown has changed everyday life and increased anxiety, fears, and stress from habitual activities such as meetings, shopping, and the use of public transport. As the worry and nervousness increase, they threaten the cognitive (Life-satisfaction) and emotional (Happiness) components of well-being. Emotional regulation strategies are a mechanism to cope with the threat.

Objective. This study assessed the impact of anxiety, perceived stress from COVID-19, and emotional regulation strategies on well-being during the first weeks of the lockdown in Russia.

Design. Questionnaire-based surveys were conducted online from March 31 to April 30, 2020. A total of 589 participants (18 to 73 years of age) were recruited. The Subjective Happiness Scale, Satisfaction with Life Scale, Zung's Self-Rating Anxiety Scale, Emotion Regulation Questionnaire, and Perceived Source of Stress from COVID-19 scales were used.

Results. Among the various sources of stress, only that from restrictions on everyday life impacted well-being. High anxiety, but not perceived stress, decreased the feelings of Happiness and Life-satisfaction. Additionally, emotional regulation strategies played different roles in their impact on well-being: Cognitive reappraisal lowered negative emotions, but emotional suppression increased dissatisfaction with life.

Conclusion. These findings suggest that people's effective and relevant regulation of their emotions during public health emergencies and ability to avoid losses caused by crisis events, have become urgent needs, requiring the development of psychological interventions to support well-being.

Keywords:

Happiness,
Life-satisfaction,
COVID-19,
perceived stress,
anxiety, emotional
regulation,
cognitive
reappraisal

Introduction

Since December 2019, COVID-19 has spread rapidly all over the world (WHO, 2020). Globally, there were 126,372,442 confirmed cases of COVID-19 and 2,769,696 deaths as of March 28, 2021 (WHO, 2021). The risk of death and the virus's effects on health have put significant psychological pressure on people all over the world (Duan & Zhu, 2020; Xiao, 2020; Ryaguzova, 2021). The continuous spread of the pandemic and implementation of quarantine measures across the globe have negatively affected people's mental health. According to the research done in China and Italy, diverse societal groups (medical staff and health workers, patients, students, and the elderly) have reported the negative psychological impact of the pandemic (Bao et al., 2020; Chen et al., 2020; Somma et al., 2020; Yang et al., 2020).

Perceived stress and the pandemic

The spread of the COVID-19 pandemic provoked stress, fears, and anxiety (Boateng et al., 2021; Ongaro et al., 2021), but these typical reactions led to different consequences (Morosanova, 2021; Zinchenko et al., 2021). They ranged from adopting behaviors to prevent infection with COVID-19, to unrealistic optimism, and negative effects on people's psychological well-being (Taylor, 2019; Cao et al., 2020; Samokhvalova et al., 2022). More than one-third of U.S. students agreed that they were stressed about the health implications of getting COVID-19 (Cohen et al., 2020). Other studies mentioned that stress symptoms became a long-term burden (Brailovskaia & Margraf, 2020), and led to low sleep quality during the coronavirus outbreak (Zhao et al., 2021b). This perceived stress can be considered one of the significant obstacles to psychological well-being, affecting general happiness and the quality of life. High perceived stress is significantly associated with increased worry, nervousness, apprehension, and somatic symptoms (Zung, 1971; Lee, 2012; Dunstan et al., 2017; Zhao et al., 2021b).

Happiness and Life-satisfaction during the pandemic

Among other features of well-being and quality of life, Happiness and Life-satisfaction play leading roles. These constructs are inherently separate and describe different elements of well-being. Happiness can be described as the predominance of a positive affect, effective emotional regulation, and the ability to cope with problems; it represents the affective component of well-being (Lyubomirsky et al., 2005). Happiness has correlated negatively with anxiety, depression, and perceived stress during the pandemic among the various social groups (Brivio et al., 2021; Yarrington et al., 2021). Life-satisfaction is the cognitive component of well-being, "referring to a judgmental process in which individuals assess the quality of their lives on the basis of their own unique set of criteria" (Pavot & Diener, 1993). Recent studies show that Life-satisfaction has negative associations with psychological distress, and that the anxiety related to the COVID-19 pandemic reduced Life-satisfaction (Duong, 2021; Shchukina & Shchirman, 2022).

Well-being enhancement involving emotional regulation strategies

According to some recent studies, people's levels of Happiness and Life-satisfaction can depend on their strategies for emotional regulation (Ng, 2018; Mahmoodi Kahriz et al., 2020). Effective emotional regulation, in turn, is associated with different psychological benefits and helps people manage many work, educational, and life challenges (Aldinger et al., 2013; Chen et al., 2020). Thus, emotional regulation strategies may be crucial to reducing the harmful effects of stress. The surge in worry and stress during the pandemic reduced well-being, and improved self-regulation may help deal with it.

The process model of emotional regulation includes two main strategies: cognitive reappraisal and expressive suppression (Gross, 2015; Gross & John, 2003). A person's preference in emotional regulation strategies correlates with differences in levels of well-being, self-esteem, and aggression (Gross & John, 2003; Goldin et al., 2014; Chen et al., 2020; Zhang et al., 2020). Using the maladaptive strategy of emotional suppression correlates with depression and a low valuation of one's happiness (Mahmoodi Kahriz et al., 2020). It has also been found that the ability to cope with uncontrollable stressful life events and Life-satisfaction are mediated by cognitive reappraisal and emotional suppression (Ng, 2018).

Anxiety, well-being, and the pandemic

Compared to the pre-pandemic state, anxiety due to the fear of the unknown (size of the pandemic, disinformation about the virus, the fatality of disease, etc.) intensified during the initial weeks of lockdown. Also, the spread of COVID-19 increased depressive symptoms and lowered emotional well-being (Low et al., 2021). Some studies reported an association between emotional suppression and anxiety during the COVID-19 pandemic because avoiding unpleasant things and feelings has paradoxically led to a rise of anxiety and worsening of well-being (Zhao et al. 202a). However, to date, there has been no direct testing of the impact of emotional regulation on the relationship between anxiety and well-being during the COVID-19 lockdown.

Study objectives

Since recognizing and appreciating the power of emotional regulation in the face of the COVID-19 pandemic is relevant to both research and practical objectives, this study aimed to test the impact of anxiety, perceived stress from COVID-19, and emotional strategies on well-being (Happiness, Life-satisfaction) in the first weeks of the lockdown. Based on previous results (Low et al., 2021; Zhao et al. 2021a), we formulated the following hypotheses: (H1) Anxiety and perceived sources of stress lower Happiness and Life-satisfaction; (H2) Different features of perceived stress have different associations with Happiness and Life-satisfaction; and (H3) Emotional regulation strategies can mediate relationships between the components of well-being and anxiety, reducing the negative impact of anxiety.

Methods

Participants

A total of 589 people from three Federal Districts in the Russian Federation (62% from the Volga Federal District; 21% from the Far Eastern Federal District; 7% from the Central Federal District; 12% not specified) were invited to complete a questionnaire (mean age 33.2, SD = 13.03 years, age range 18–73). Among them, 24% were male, 31% were students, and only 5% worked in medical professions. Most participants (92.8%) had at least a university degree or were university students.

Procedure

Social networks were used to distribute the questionnaire. The participants were asked to report on their health status at the time of the survey. None reported pandemic-related symptoms. All questionnaires were presented to participants in the same order. Every participant in the survey received a report on his or her anxiety, stress level, and regulation strategies after completing the evaluation. Participation in the study was completely voluntary and unpaid.

The data was collected from March 31 to April 30, 2020. Over that time period, Russia's coronavirus cases grew from 2,337 to 106,498. During this period, to avoid the spread of the coronavirus, the state government restricted foreign flights and travel, prohibited sports and cultural activities, and recommended online forms for education and employment. Throughout the country, the media spread information about the dangers and effects of COVID-19, and rigorous sanitation and health-related measures were implemented and strongly enforced (Plotnikov, 2020).

Questionnaires

All participants completed the questionnaires, which included Zung's Self-Rating Anxiety Scale (Zung, 1971); the Emotion Regulation Questionnaire (ERQ) (Gross & John, 2003); a modified Perceived Source of Stress Scale (Wong et al., 2007); the Subjective Happiness Scale (SHS) (Lyubomirsky and Lepper, 1999); and the Satisfaction with Life Scale (SWLS) (Diener et al., 1985).

Zung's Self-Rating Anxiety Scale (SAS) (Zung, 1971; Mammadova et al., 2012) consists of 20 questions with a four-point Likert-type scale to grade their responses. The SAS has shown good internal consistency, with a Cronbach's alpha of 0.85 for this study.

The Russian version of the Emotion Regulation Questionnaire (ERQ) (Gross & John, 2003; Pankratova & Kornienko, 2017) was used to measure the two emotional regulation strategies: Cognitive Reappraisal and Emotional Suppression. The ERQ is a 10-item self-reported measure where each item is rated on a 7-point Likert scale. This questionnaire demonstrated a good Cronbach's alpha: 0.83 for the Cognitive Reappraisal subscale, and 0.72 for the Emotional Suppression one.

The participants' perceived sources of stress from the COVID-19 outbreak were measured with a 20-item questionnaire that described various situations one might encounter during the pandemic. A 6-point Likert-type scale ranging from 1 (never)

to 6 (severe) was used to grade their responses. This questionnaire was based on Wong et al.'s (2007) scale for measuring the perceived source of stress from SARS. For this study, only one modification was made — replacing “SARS” with “COVID-19” — because these two diseases have similar epidemiology, pathogenesis, and clinical characteristics (Liu et al., 2020).

Five scales were measured: 1) Stress from Fear of Infection (e.g., “I feel that I might be infected by the COVID-19 virus at any moment”); 2) Stress from Virus Spreading (e.g., “I feel COVID-19 will spread quickly”); 3) Stress from Pandemic Outcomes (e.g., “I feel that COVID-19 patients might suffer serious consequences”); 4) Stress from Everyday Life Restrictions (e.g., “I feel COVID-19 restricts my social meetings with my friends”); and 5) Stress from Places and Transport (e.g., “I am afraid to take any public transport”). The Cronbach's alpha for the scales varied from 0.63 to 0.88 for this study.

The Subjective Happiness Scale (SHS) (Lyubomirsky & Lepper, 1999; Osin & Leontiev, 2020) was used. This scale includes four items on global happiness. The response format is a 7-point Likert scale. For this study Cronbach's alpha was 0.76.

The judgmental component of subjective well-being was measured using the Satisfaction with Life Scale (SWLS) (Dinner et al., 1985; Osin & Leontiev, 2020). This scale involves five items describing opinions on Life Satisfaction as a whole, using a 7-point Likert scale. Cronbach's alpha for this scale was 0.84.

Data analysis

The data were analyzed using a psych package in R environment, IBM SPSS Statistics 20 and PROCESS, a computational plugin for SPSS that conducts mediation, moderation, and conditional process modelling (Hayes, 2013). Pearson's correlation analysis was used to study the relationships between the variables, and multiple linear regression and mediation analysis was used for testing the direct and indirect effects of the variables on anxiety. Mediation analyses were conducted using the bootstrapping technique proposed by Preacher and Hayes (2004). Bootstrapping does not assume a normal distribution; therefore, 5,000 bootstrap samples were used to obtain 95% CIs and test the significance of the indirect effects.

Results

First, we analyzed the overall picture of the relationships between anxiety, emotional regulation strategies, perceived sources of stress from the COVID-19 outbreak, and the levels of Happiness and Life-satisfaction. A comparison of the variables' medians with a median of a normal distribution in the Likert scale range was done to demonstrate the levels of these variables during the COVID-19 pandemic.

At the level of bivariate correlation, Happiness and Life-satisfaction demonstrated a strong correlation ($r = 0.62$, $p < 0.05$) (Table 1). Happiness, as well as Life-satisfaction, were negatively associated with Anxiety ($r = -0.40$ for Happiness, $r = -0.34$ for Life Satisfaction, $p < 0.01$). Happiness and two perceived sources of stress variables had negative associations: Stress from Pandemic Outcomes ($r = -0.11$, $p < 0.05$) and Stress from Everyday Life Restrictions ($r = -0.15$, $p < 0.01$). Life-satisfaction demon-

strated the same correlations with perceived sources of stress variables (Stress from Pandemic Outcomes ($r = -0.10, p < 0.05$), and Stress from Everyday Life Restrictions ($r = -0.16, p < 0.01$)).

Table 1
Means, standard deviations, and correlations

Variable	M	SD	1	2	3	4	5	6	7	8	9
1. Happiness	4.79	1.15									
2. Life Satisfaction	4.14	1.29	0.62**								
3. Anxiety	35.8	0.41	-0.40**	-0.34**							
4. Cognitive reappraisal	5.01	1.05	0.30**	0.25**	-0.18**						
5. Emotional suppression	3.40	1.18	-0.11**	-0.02	0.06	0.16**					
6. Stress from Fear of Infection	2.92	0.90	-0.05	-0.03	0.30**	-0.03	0.06				
7. Stress from Virus Spread	4.28	0.87	-0.07	-0.01	0.21**	0.03	0.00	0.50**			
8. Stress from Pandemic Outcomes	3.36	0.75	-0.11*	-0.10*	0.30**	-0.01	0.09*	0.40**	0.47**		
9. Stress from Everyday Life Restriction	4.20	0.96	-0.15**	-0.16**	0.31**	0.02	0.10*	0.25**	0.27**	0.34**	
10. Stress from Places and Transport	3.58	1.26	-0.01	-0.01	0.21**	0.12**	-0.02	0.51**	0.49**	0.42**	0.28**

Note: * indicates $p < .05$; ** indicates $p < .01$.

Happiness correlated with both emotional regulation strategies; positively with Cognitive Reappraisal ($r = 0.30, p < 0.01$) and negatively with Emotional Suppression ($r = -0.11, p < 0.01$). Life-satisfaction only had a positive correlation with Cognitive Reappraisal ($r = 0.25, p < 0.01$).

Anxiety negatively correlated with Cognitive Reappraisal ($r = -0.18, p < 0.01$), but not with Emotional Suppression. Anxiety was positively associated with all perceived sources of stress from the COVID-19 outbreak variables ($r = 0.21:0.38, p < 0.01$). Cognitive Reappraisal positively correlated only with Stress from Places and Transport ($r = 0.12, p < .05$), and Emotional Suppression with Stress from Pandemic Outcomes ($r = 0.09, p < 0.05$) and Stress from Everyday Life Restrictions ($r = 0.10, p < 0.05$). Anxiety negatively correlated with Cognitive Reappraisal ($r = -0.18, p < 0.01$) but not Emotional Suppression.

Next, two hierarchical regression analyses were performed. (See Table 2) Happiness and Life-satisfaction were the dependent variables in each regression. First, we

added demographic variables (Gender, Age) and Anxiety; then the perceived sources of stress variables were added in Step 2. Finally, emotional regulation strategies were included in the model.

Table 2
Regression results for Happiness and Life-satisfaction

Predictor	Happiness		Live Satisfaction	
	b	beta	b	beta
(Intercept)	6.14**		5.31**	
Gender	0.27*	0.10*	0.45**	0.15**
Age	0.01	0.07	0.00	0.00
Anxiety	-1.13**	-0.40**	-1.11**	-0.35**
Regression result for Step 1	$R^2 = .182^{**}$		$R^2 = .140^{**}$	
(Intercept)	6.26**		5.33**	
Gender	0.27*	0.10*	0.45**	0.15**
Age	0.01	0.06	0.00	0.00
Anxiety	-1.16**	-0.41**	-1.11**	-0.35**
Stress from Fear of Infection	0.10	0.08	0.10	0.07
Stress from Virus Spread	-0.05	-0.03	0.07	0.04
Stress from Pandemic Outcomes	-0.01	-0.01	-0.05	-0.03
Stress from Everyday Life Restriction	-0.06	-0.05	-0.12*	-0.09*
Stress from Places and Transport	0.04	0.05	0.02	0.02
Regression results for Step 2	$R^2 = .192^{**}, \Delta R^2 = .009$		$R^2 = .153^{**}, \Delta R^2 = .013$	
(Intercept)	5.40**		4.26**	
Gender	0.15	0.06	0.43**	0.14**
Age	0.00	0.03	-0.00	-0.03
Anxiety	-1.02**	-0.36**	-0.99**	-0.31**
Stress from Fear of Infection	0.13*	0.10*	0.11	0.08
Stress from Virus Spread	-0.06	-0.05	0.06	0.04
Stress from Pandemic Outcomes	0.02	0.01	-0.04	-0.03
Stress from Everyday Life Restriction	-0.07	-0.05	-0.13*	-0.10*
Stress from Places and Transport	0.00	0.01	-0.01	-0.01
Cognitive reappraisal	0.27**	0.24**	0.22**	0.18**
Emotional suppression	-0.11**	-0.11**	0.01	0.01
Regression results for Step 3	$R^2 = .245^{**}, \Delta R^2 = .054^{**}$		$R^2 = .183^{**}, \Delta R^2 = .030^{**}$	

Note. b represents unstandardized regression weights; beta indicates the standardized regression weights. Gender was coded as follows: Male = 1; Female = 2; * indicates $p < .05$; ** indicates $p < .01$.

In the final step, the analysis was found to be statistically significant ($F(10, 580) = 18.78$; $p < 0.001$). This regression accounted for 24.5% of the variability for Happiness, with four significant predictors. As seen in *Table 2*, Anxiety remained a consistent negative predictor of Happiness from Step 1 to Step 3. Among the perceived sources of stress variables, Stress from Fear of Infection was revealed as a significant predictor for Happiness. Both emotional regulation strategies (Cognitive Reappraisal and Emotional Suppression), added at Step 3, were significant predictors and the explained variance of the model increased ($R^2 = 0.245^{**}$; $\Delta R^2 = 0.054^{**}$). Anxiety was the strongest predictor for Happiness, and an increase in Anxiety lowered Happiness even after controlling for gender, age, perceived sources of stress variables, and emotional regulation strategies. The second predictor which decreased Happiness was Emotional Suppression. Cognitive Reappraisal and Stress from Fear of Infection led to an increase in Happiness.

The regression model for Life-satisfaction (*Table 2*) in the final step explained 18.3% of variability ($F(10, 580) = 12.96$; $p < 0.001$) with three significant predictors; *i.e.*, Anxiety ($\beta = -0.31$, $p < 0.01$), Cognitive Reappraisal ($\beta = 0.18$, $p < 0.01$), and Stress from Everyday Life Restrictions ($\beta = -0.10$, $p < 0.05$). Among the psychological variables, Anxiety was the main predictor for Life-satisfaction in all regression analysis steps with the highest regression weights. Cognitive Reappraisal, but not Emotional Suppression, was revealed as the next significant predictor, and Stress from Everyday Life Restriction had a smaller effect on the variance of Life-satisfaction. It should be mentioned that gender remained a significant predictor at all steps of analysis. Thus, Life-satisfaction, as predicted by Anxiety, Cognitive Reappraisal and Stress from Everyday Life Restrictions, differed according to the gender of the respondents.

Mediation analysis

The indirect effect of emotional regulation strategies on Happiness and Life-satisfaction was tested using a bootstrapping technique proposed by Preacher and Hayes (2004) with 5,000 bootstrap samples. An indirect effect's significance is indicated if the 95% confidence interval (CI) does not include zero. To test the hypotheses, two different mediation analyses involving emotional regulation strategies as mediators were conducted.

The indirect effect of Cognitive Reappraisal on Happiness was close to being significant ($b = -0.13$, $SE = 0.04$, $CI = -0.214, -0.064$), and the indirect effects of Emotional Suppression on Happiness were not significant. The same was found for Life-satisfaction. Cognitive Reappraisal's indirect effect was close to being significant ($b = -0.12$, $SE = 0.04$, $CI = -0.19: -0.05$), and no indirect effect of Emotional Suppression was found. Emotional strategies did not mediate the relationship between Anxiety, and Happiness and Life-satisfaction in this study.

Discussion

Happiness and Life-satisfaction had the same patterns of associations with other study variables. The fact that anxiety and the perception of the environment as stressful were related to lower levels of Happiness and Life-satisfaction in our study is not

surprising. The increase of anxiety and COVID-19-related stress might result from the virus prevention measures' influence on social and everyday life, including both people's personal and the overall economic situation. Some previous findings corroborated these associations between anxiety and ill-being, depression, and poor sleep quality (Huang & Zhao, 2020; Zhao et al., 2021b; Pervichko et al., 2022).

We may consider the detrimental role of anxiety as a predictor of Happiness and Life-satisfaction. Anxiety, which accounted for more variance than the other characteristics, explained why some people were more stressed by the pandemic (H1). Therefore, anxiety not only played a negative role but also worked as an enhancer that leads to greater sensitivity to one's health during a stressful event. In this way, we can speculate that anxiety intensifies the perception of all environments as stressful. This assumption was partially supported by the results of recent research on perceived stress in the world due to the COVID-19 pandemic (Gamonal-Limcaoco et al., 2021), and the fact that high levels of general anxiety might provoke a more severe anxious response to the spread of diseases (Sebri et al., 2021, Blakey & Abramowitz, 2017).

The COVID-19-related perceived risk features had significant but statistically small effects on Happiness and Life-satisfaction (H2). Surprisingly, Stress from Fear of Infection has a relatively small but positive impact on Happiness. Looking at the associations between Stress from Fear of Infection and Anxiety, we may speculate that the incremental effect of Stress from Fear of Infection showed up because of this link. We can suggest a different explanation for the relationship between Stress from Fear of Infection and Happiness. Stress from Fear of Infection increases worries, nervousness, and anxiety, leading to an adaptive strategy to cope with these adverse conditions and to developing cognitive reappraisal. As a result, against the background of the threat of COVID-19 infection, one's existing lifestyle and achievements begin to be perceived as something valuable. This conclusion could account for a rise in the level of Happiness during the COVID-19 pandemic, but this hypothesis needs additional study and analysis.

Stress from Everyday Life Restrictions had a small effect on Life-satisfaction. According to the result of this study, the limitation of sports activity, social meetings, and the usual course of life lowered subjective well-being. The same results were found in a study of Chinese students, whose results postulated that stress from the pandemic effects on daily life and the delay of academic activities are positively associated with anxiety symptoms and provoke negative emotions (Cao et al., 2020).

Our findings demonstrate that emotional regulation strategies differ in their associations according to the perceived sources of COVID-19 stress. The link between Cognitive Reappraisal, Emotional Suppression, and different pandemic fears may indicate the possible use of emotional regulation strategies to cope with various sources of stress. For example, according to previous studies, before the COVID-19 threat, it was found that Cognitive Reappraisal lowers the emotional reaction to a negative stimulus (Olatunji et al., 2017). However, during the pandemic, this link changed. The reality of infection and its awareness might influence the view of public places as unsafe, which explains a positive relationship between Cognitive Reappraisal and Stress from Places and Transportation.

Emotional regulation strategies had different impacts on Happiness and Life-satisfaction. Previous studies have shown the significantly different roles of adaptive and dysfunctional coping strategies for decreasing or increasing negative emotions during the pandemic (Cincidda et al., 2021). In particular, Restubog et al. (2020) have proven that Cognitive Reappraisal as an adaptive strategy reduces the adverse effects of negative emotions and enhances well-being, and our results confirmed that (H3).

Concerning Life-satisfaction, only Cognitive Reappraisal as an emotional regulation strategy was revealed as a predictor. Many studies consistently prove that adaptive emotional regulation strategies (cognitive reappraisal) are advantageous in reducing symptoms of anxiety (Malikin, et al., 2020; Sebri et al., 2021). People who use cognitive reappraisal negotiate stressful situations by taking an optimistic attitude, reinterpreting what they consider stressful, and making active efforts to avoid bad moods, which should be a protective factor of psychological problems throughout the pandemic situation.

Conversely, the use of maladaptive emotional regulation strategies (emotional suppression) may play a detrimental role in Happiness and Life-satisfaction. Emotional suppression manages the expression of sadness or anxiety, increasing the intensity of those feelings (Gross & John, 2003; Sebri et al., 2021, Dryman & Heimberg, 2018). However, individuals might handle challenging or threatening events successfully through an effective reduction of negative emotions. Current results corroborate previous data about emotional suppression's impact on emotional experience, social functioning, and overall well-being (Gubler et al., 2021, Dryman & Heimberg, 2018).

Life-satisfaction during the lockdown period was affected by psychological factors such as perceived stress, anxiety, and emotional regulation, and it varied by gender. This finding is consistent with a recent study, which found that women have higher life satisfaction across all social, age, and geographic groups (Joshanloo & Jovanović, 2020), although during the first wave of the pandemic they could demonstrate a higher level of anxiety, avoidance, and hyperarousal (Brivio et al., 2021).

Conclusion

The point of this study was to explore the effects of anxiety and perceived stress from the COVID-19 pandemic, as well as emotional regulation strategies, during the initial weeks of the lockdown and social isolation.

Psychological health decreased during the COVID-19 outbreak, so researching the mechanisms for coping and regulating emotion is an important task. We identified that high levels of anxiety might be an explanation for the lower level of Happiness and Life-satisfaction during the lockdown period.

Emotional regulation strategies differed in their impacts on well-being. Cognitive reappraisal as an adaptive strategy for dealing with worries and nervousness helped to boost Happiness and Life-satisfaction. In contrast, emotional suppression intensified the feeling of dissatisfaction with life.

We have little evidence that perceived stress from fear of infection would affect Happiness, and that stress from restrictions on everyday life would affect Life-satisfaction. Because the data collection occurred immediately after the lockdown, we

might suppose that other sources of stress remained unperceived for some time. We might also propose that anxiety commuted the stress from different sources and revealed it as an overall state that affects well-being. We might speculate that during the first weeks of the lockdown, individual emotional states exceeded the cognitive evaluation and behavioral changes that led to worry and nervousness about the pandemic, and apprehension of disease. Through the early days of the COVID-19 lockdown, the restrictive measures and the virus's perceived danger threatened societal normalcy, stability, and well-being, revealing anxiety as a prevalent factor in contrast to a rational understanding of potential risks.

The lessons acquired from the pandemic have demonstrated that psychological support should be focused not just on patients and confined individuals, but also on the broader public, to promote psychological well-being. Understanding the cognitive aspects of emotional regulation might pave the way for the development of psychological prevention to avert or mitigate the detrimental effects of pandemics on well-being. Measuring perceived sources of stress during a pandemic might aid future research in evaluating the impact of anxiety-producing events in various locales and in clearly identifying the areas for preventative action.

Limitations

This study had several limitations. First, it is difficult to make causal inferences despite the data and relevant analyses because of the study design. Second, due to the study's reliance on a web-based survey and the snowball sampling of participants, the possibility of selection bias must be considered. Third, participants were given the questionnaires in the same order each time, and the probability of the impact of one test's responses on the next test's responses was not taken into account. Fourth, it was impossible to assess the participants' pre-COVID-19 societal psychological characteristics. Fifth, the high rate of female participants and the prevalence of participants from one region may have hindered the validity of the obtained results. These limitations suggest that applying our findings to the general population should be done with care.

Ethics Statement

The testing procedures met ethical standards adopted at the Russian Presidential Academy of National Economy & Public Administration and the National Research University Higher School of Economics. Participants took part in the research voluntarily and gave written consent to participate in the study before testing.

The respondents gave written consent to the processing, systematization, accumulation, storage, and use of personal data before testing.

Author Contributions

DK and NR came up with the research idea and study design, they collected the data and formed the database. DK made a statistical analysis of the data and drafted the manuscript. DK and NR revised the manuscript together and approved the submitted version.

Conflict of Interest

The authors declare that the research was conducted in the absence of any commercial or financial relationships that could be construed as a potential conflict of interest.

References

- Aldinger, M., Stopsack, M., Barnow, S., Rambau, S., Spitzer, C., Schnell, K., & Ulrich, I. (2013). The association between depressive symptoms and emotion recognition is moderated by emotion regulation. *Psychiatry Research*, *205*(1), 59–66. <https://doi.org/10.1016/j.psychres.2012.08.032>
- Bao, Y., Sun, Y., Meng, S., Shi, J., & Lu, L. (2020). 2019-nCoV epidemic: Address mental health care to empower society. *The Lancet*, *395*(10224), 37–38. [https://doi.org/10.1016/S0140-6736\(20\)30309-3](https://doi.org/10.1016/S0140-6736(20)30309-3)
- Boateng, G.O., Doku, D.T., Enyan, N.I.E., Owusu, S.A., Aboh, I.K., Kodom, R.V., ... Armah, F.A. (2021). Prevalence and changes in boredom, anxiety and well-being among Ghanaians during the COVID-19 pandemic: a population-based study. *BMC Public Health*, *21*, 985. <https://doi.org/10.1186/s12889-021-10998-0>
- Brailovskaia, J., & Margraf, J. (2020). Predicting adaptive and maladaptive responses to the Coronavirus (COVID-19) outbreak: A prospective longitudinal study. *International Journal of Clinical and Health Psychology*, *20*(3), 183–191. <https://doi.org/10.1016/j.ijchp.2020.06.002>
- Brivio, E., Oliveri, S., Guiddi, P., & Pravettoni, G. (2021). Incidence of PTSD and generalized anxiety symptoms during the first wave of COVID-19 outbreak: an exploratory study of a large sample of the Italian population. *BMC Public Health*, *21*, 1158. <https://doi.org/10.1186/s12889-021-11168-y>
- Cao, W., Fang, Z., Hou, G., Han, M., Xu, X., Dong, J., & Zheng, J. (2020). The psychological impact of the COVID-19 epidemic on college students in China. *Psychiatry Research*, *287*, 112934. <https://doi.org/10.1016/j.psychres.2020.112934>
- Chen, J., Zhang, C., Wang, Y., & Xu, W. (2020). A longitudinal study of inferiority impacting on aggression among college students: The mediation role of cognitive reappraisal and expression suppression. *Personality and Individual Differences*, *157*, 109839. <https://doi.org/10.1016/j.paid.2020.109839>
- Cincidda, C., Pizzoli, S.F.M., Oliveri, S., & Pravettoni, G. (2021). Regulation strategies during COVID-19 quarantine: the mediating effect of worry on the links between coping strategies and anxiety. *European Review of Applied Psychology*. (In press) <https://doi.org/10.1016/j.erap.2021.100671>
- Cohen, A.K., Hoyt, L.T., & Dull, B. (2020). A descriptive study of Coronavirus disease 2019–related experiences and perspectives of a national sample of college students in spring 2020. *Journal of Adolescent Health: Official publication of the Society for Adolescent Medicine*, *67*(3), 369–375. <https://doi.org/10.1016/j.jadohealth.2020.06.009>
- Diener, E., Emmons, R.A., Larsen, R.J., & Griffin, S. (1985). The Satisfaction with Life Scale. *Journal of Personality Assessment*, *49*(1), 71–75. https://doi.org/10.1207/s15327752jpa4901_13
- Dryman, M.T., & Heimberg, R.G. (2018). Emotion regulation in social anxiety and depression: A systematic review of expressive suppression and cognitive reappraisal. *Clinical Psychology Review*, *65*, 17–42. <https://doi.org/10.1016/j.cpr.2018.07.004>
- Duan, L., & Zhu, G. (2020). Psychological interventions for people affected by the COVID-19 epidemic. *The Lancet Psychiatry*, *7*(4), 300–302. [https://doi.org/10.1016/S2215-0366\(20\)30073-0](https://doi.org/10.1016/S2215-0366(20)30073-0)
- Dunstan, D.A., Scott, N., & Todd, A.K. (2017). Screening for anxiety and depression: Reassessing the utility of the Zung scales. *BMC Psychiatry*, *17*(1), 329. <https://doi.org/10.1186/s12888-017-1489-6>
- Duong, C.D. (2021). The impact of fear and anxiety of Covid-19 on life satisfaction: Psychological distress and sleep disturbance as mediators. *Personality and Individual Differences*, *178*, 110869. <https://doi.org/10.1016/j.paid.2021.110869>
- Gamonal-Limcaoco, S., Montero-Mateos, E., Lozano-López, M.T., Maciá-Casas, A., Matías-Fernández, J., & Roncero, C. (2021). Perceived stress in different countries at the beginning of the coronavirus pandemic. *The International Journal of Psychiatry in Medicine*. <https://doi.org/10.1177/009121742111033710>

- Goldin, P.R., Jazaieri, H., & Gross, J.J. (2014). Emotion Regulation in Social Anxiety Disorder. In *Social Anxiety* (p. 511–529). Elsevier. <https://doi.org/10.1016/B978-0-12-394427-6.00017-0>
- Gross, J.J. (2015). Emotion regulation: Current status and future prospects. *Psychological Inquiry*, 26(1), 1–26. <https://doi.org/10.1080/1047840X.2014.94078>
- Gross, J.J., & John, O.P. (2003). Individual differences in two emotion regulation processes: Implications for affect, relationships, and well-being. *Journal of Personality and Social Psychology*, 85(2), 348–362. <https://doi.org/10.1037/0022-3514.85.2.348>
- Gubler, D.A., Makowski, L.M., Troche, S.J., & Schlegel, K. (2021). Loneliness and well-being during the Covid-19 pandemic: Associations with personality and emotion regulation. *Journal of Happiness Studies*, 22, 2323–2342. <https://doi.org/10.1007/s10902-020-00326-5>
- Hayes, A.F. (2013). *Introduction to mediation, moderation, and conditional process analysis: A regression-based approach*. Guilford Press.
- Huang, Y., & Zhao, N. (2020). Generalized anxiety disorder, depressive symptoms and sleep quality during COVID-19 outbreak in China: A web-based cross-sectional survey. *Psychiatry Research*, 288, 112954. <https://doi.org/10.1016/j.psychres.2020.112954>
- Joshanloo, M., & Jovanović, V. (2020) The relationship between gender and life satisfaction: analysis across demographic groups and global regions. *Archives of Women's Mental Health*, 23, 331–338. <https://doi.org/10.1007/s00737-019-00998-w>
- Lee, E.-H. (2012). Review of the psychometric evidence of the Perceived Stress Scale. *Asian Nursing Research*, 6(4), 121–127. <https://doi.org/10.1016/j.anr.2012.08.004>
- Lee, S. M., Kang, W.S., Cho, A.-R., Kim, T., & Park, J.K. (2018). Psychological impact of the 2015 MERS outbreak on hospital workers and quarantined hemodialysis patients. *Comprehensive Psychiatry*, 87, 123–127. <https://doi.org/10.1016/j.comppsy.2018.10.003>
- Liu, Q., Xu, K., Wang, X., & Wang, W. (2020). From SARS to COVID-19: What lessons have we learned? *Journal of Infection and Public Health*, 13(11), 1611–1618. <https://doi.org/10.1016/j.jiph.2020.08.001>
- Low, R.S.T., Overall, N.C., Chang, V.T., Henderson, A M.E., & Sibley, C.G. (2021). Emotion regulation and psychological and physical health during a nationwide COVID-19 lockdown. *Emotion*. Advance online publication. <http://dx.doi.org/10.1037/emo0001046>
- Lyubomirsky, S., & Lepper, H.S. (1999). A measure of subjective happiness: Preliminary reliability and construct validation. *Social Indicators Research*, 46(2), 137–155. <https://doi.org/10.1023/A:1006824100041>
- Lyubomirsky, S., King, L., & Diener, E. (2005). The benefits of frequent positive affect: Does happiness lead to success? *Psychological Bulletin*, 131(6), 803–855. <https://doi.org/10.1037/0033-2909.131.6.803>
- Mahmoodi Kahriz, B., Bower, J.L., Glover, F.M.G.Q., & Vogt, J. (2020). Wanting to be happy but not knowing how: Poor attentional control and emotion-regulation abilities mediate the association between valuing happiness and depression. *Journal of Happiness Studies*, 21(7), 2583–2601. <https://doi.org/10.1007/s10902-019-00193-9>
- Malikin, H., Marchica, L., & Montreuil, T. (2020). Trait anxiety moderated by emotion regulation to predict mindful awareness. *Personality and Individual Differences*, 163, 110072. <https://doi.org/10.1016/j.paid.2020.110072>
- Mammadova, F., Sultanov, M., Hajiyeva, A., Aichberger, M., & Heinz, A. (2012). Translation and adaptation of the Zung Self-Rating Depression Scale for application in the bilingual Azerbaijani population. *European Psychiatry*, 27(2), 27–31. [https://doi.org/10.1016/S0924-9338\(12\)75705-X](https://doi.org/10.1016/S0924-9338(12)75705-X)
- Morosanova, V.I. (2021) Osoznannaya samoregulyaciya kak metaresurs dostizheniya celej i razresheniya problem zhiznedeyatel'nosti [Conscious self-regulation as a meta-resource for achieving goals and solving the problems of human activity]. *Vestnik Moskovskogo Universiteta. Seriya 14. Psikhologiya* [Moscow University Psychology Bulletin], 1, 4–37. <https://doi.org/10.11621/vsp.2021.01.01>
- Ng, Z.J. (2018). *Emotion Regulation and Life Satisfaction of Early Adolescents in the Face of Stressful Life Events*. Doctoral dissertation. University of South Carolina. College of Arts and Sciences.
- Olatunji, B.O., Berg, H., Cox, R.C., & Billingsley, A. (2017). The effects of cognitive reappraisal on conditioned disgust in contamination-based OCD: An analogue study. *Journal of Anxiety Disorders*, 51, 86–93. <https://doi.org/10.1016/j.janxdis.2017.06.005>

- Ongaro, G., Cincidda, C., Sebri, V., Savioni, L., Triberti, S., Ferrucci, R., ... Pravettoni, G. (2021). A 6-Month Follow-Up Study on Worry and Its Impact on Well-Being During the First Wave of COVID-19 Pandemic in an Italian Sample. *Frontiers in Psychology, 12*, 703214. <https://doi.org/10.3389/fpsyg.2021.703214>
- Osin, E.N., & Leontiev, D.A. (2020). Brief Russian language instruments to measure subjective well-being: psychometric properties and comparative analysis. *Monitoring of Public Opinion: Economic and Social Changes, 1*, 117–142. <https://doi.org/10.14515/monitoring.2020.1.06>
- Pankratova, A.A., & Kornienko, D.S. (2017). A Russian adaptation of the Emotional Regulation Questionnaire (J. Gross). *Voprosy Psikhologii, 5*, 139-148.
- Pavot, W., & Diener, E. (1993). Review of the Satisfaction with Life Scale. *Psychological Assessment, 5*(2), 164–172. <https://doi.org/10.1037/1040-3590.5.2.164>
- Pervichko E.I., Mitina O.V., Stepanov O.B., Konyukhovskaya, Y.E., Shishkova, I.M., & Dorokhov, E.A. (2022). Perceptions of the COVID-19 Pandemic and Psychological Distress amongst Russian Citizens during Spring 2020. *Consortium Psychiatricum, 3*(2), 70-86. <https://doi.org/10.17816/CP136>
- Plotnikov, V.A. (2020). The COVID-19 pandemic and the behavior of the Russians: some observations. *Teoriya i praktika servisa: ehkonomika, sotsial'naya sfera, tekhnologii, 2* (44), 19-23.
- Preacher, K.J., & Hayes, A.F. (2004). SPSS and SAS procedures for estimating indirect effects in simple mediation models. *Behavior Research Methods, Instruments, & Computers, 36*(4), 717–731. <https://doi.org/10.3758/BF03206553>
- Restubog, S.L.D., Ocampo, A.C.G., & Wang, L. (2020). Taking control amidst the chaos: Emotion regulation during the COVID-19 pandemic. *Journal of Vocational Behavior, 119*, 103440. <https://doi.org/10.1016/j.jvb.2020.103440>
- Ryaguzova, E. V. (2021). Cognitive aspects of students' attitudes towards COVID-19 vaccination. *Russian Psychological Journal, 18*(2), 109–121. <https://doi.org/10.21702/rpj.2021.2.7>
- Samokhvalova, A.G., Saporovskaia, M.V., Khazova, S.A., Tikhomirova, E.V., Shipova, N.S. (2022). Coping with the forced separation of close relationships during the COVID-19 pandemic. *Psychology in Russia: State of the Art, 15*(3), 75–90. <https://doi.org/10.11621/pir.2022.0305>
- Sebri, V., Cincidda, C., Savioni, L., Ongaro, G., & Pravettoni, G. (2021). Worry during the initial height of the COVID-19 crisis in an Italian sample. *The Journal of General Psychology, 148*(3), 327–359. <https://doi.org/10.1080/00221309.2021.1878485>
- Shchukina, M.A., Shchirman, L.A. (2022) Psihologicheskie prediktory udovletvorennosti zhizn'yu lyudej starshego vozrasta (na primere klientov blagotvoritel'nogo fonda) [Psychological predictions of life satisfaction for older persons (the example of charity fund clients)]. *Natsional'nyy psikhologicheskii zhurnal* [National psychological journal], 1 (45), 15–29. <https://doi.org/10.11621/npj.2022.0102>
- Somma, A., Gialdi, G., Krueger, R.F., Markon, K.E., Frau, C., Lovallo, S., et al. (2020). Dysfunctional personality features, non-scientifically supported causal beliefs, and emotional problems during the first month of the COVID-19 pandemic in Italy. *Personality and Individual Differences, 165*, 110139. <https://doi.org/10.1016/j.paid.2020.110139>
- Taylor, S. (2019). *The Psychology of Pandemics: Preparing for the Next Global Outbreak of Infectious Disease*. Cambridge Scholars Publishing.
- Wong, T.W., Gao, Y., & Tam, W.W.S. (2007). Anxiety among university students during the SARS epidemic in Hong Kong. *Stress and Health, 23*(1), 31–35. <https://doi.org/10.1002/smi.1116>
- World Health Organization (WHO) (2020). Coronavirus disease 2019 (COVID-19). Situation Report – 1. January 20th, 2020. https://www.who.int/docs/default-source/coronaviruse/situation-reports/20200121-sitrep-1-2019-ncov.pdf?sfvrsn=20a99c10_4
- World Health Organization (WHO) (2021). Weekly epidemiological update on COVID-19. March 28th, 2021. https://www.who.int/docs/default-source/coronaviruse/situation-reports/20210330-weekly_epi_update_33.pdf
- Xiao, C. (2020). A novel approach of consultation on 2019 novel coronavirus (COVID-19)-related psychological and mental problems: structured letter therapy. *Psychiatry Investigation, 17*(2), 175–176. <https://doi.org/10.30773/pi.2020.0047>

- Yang, Y., Li, W., Zhang, Q., Zhang, L., Cheung, T., & Xiang, Y.-T. (2020). Mental health services for older adults in China during the COVID-19 outbreak. *The Lancet Psychiatry*, 7(4), e19. [https://doi.org/10.1016/S2215-0366\(20\)30079-1](https://doi.org/10.1016/S2215-0366(20)30079-1)
- Yarrington, J.S., Lasser, J., Garcia, D., Vargas, J.H., Couto, D.D., Marafon, T., et al. (2021). Impact of the COVID-19 pandemic on mental health among 157,213 Americans. *Journal of Affective Disorders*, 286, 64–70. <https://doi.org/10.1016/j.jad.2021.02.056>
- Zhang, L., Lu, J., Li, B., Wang, X., & Shangguan, C. (2020). Gender differences in the mediating effects of emotion-regulation strategies: Forgiveness and depression among adolescents. *Personality and Individual Differences*, 163, 110094. <https://doi.org/10.1016/j.paid.2020.110094>
- Zhao, T., Fu, Z., Lian, X., Ye, L. & Huang, W. (2021a) Exploring emotion regulation and perceived control as antecedents of anxiety and its consequences during Covid-19 full remote learning. *Frontiers in Psychology*, 12, 675910. <https://doi.org/10.3389/fpsyg.2021.675910>
- Zhao, X., Lan, M., Li, H., & Yang, J. (2021b). Perceived stress and sleep quality among the non-diseased general public in China during the 2019 coronavirus disease: a moderated mediation model. *Sleep Medicine*, 77, 339–345. <https://doi.org/10.1016/j.sleep.2020.05.021>
- Zinchenko, Yu. P., Shaigerova, L.A., Almazova, O.V., Kalimullin A. (2021) The Spread of COVID-19 in Russia: Immediate Impact on Mental Health of University Students. *Psychological Studies*, 66, 291–302. <https://doi.org/10.1007/s12646-021-00610-1>
- Zung, W.W.K. (1971). A rating instrument for anxiety disorders. *Psychosomatics*, 12(6), 371–379. [https://doi.org/10.1016/S0033-3182\(71\)71479-0](https://doi.org/10.1016/S0033-3182(71)71479-0)

Original manuscript received April 18, 2022

Revised manuscript accepted February 28, 2023

First published online March 30, 2023

To cite this article: Kornienko, D.S., Rudnova, N.A. (2023). Exploring the Associations between Happiness, Life-satisfaction, Anxiety, and Emotional Regulation among Adults during the Early Stage of the COVID-19 Pandemic in Russia. *Psychology in Russia: State of the Art*, 16(1), 98–112. DOI: 10.11621/pir.2023.0106

Determinants of Russian Attitudes Toward a Green Economy During the Covid-19 Pandemic

Aleksandr A. Maksimenko^{a*}, Olga S. Deyneka^b, Ekaterina V. Zabelina^c

^a HSE University, Moscow, Russia

^b St. Petersburg University, Russia

^c Chelyabinsk State University, Russia

*Corresponding author. Email Maximenko.Al@gmail.com

Background. The development of environmental consciousness is a necessary part of the full development of society. The pandemic caused by COVID-19 has increased attention to the problems of man's relationship with nature, and the green behavior of both the consumer and the producer. Attitudes toward a green economy are especially important to study in countries rich in natural resources, as they have more opportunities to overcome the contradictions between economic growth and green innovation.

Objective. The purpose of this study was to identify the determinants of Russian attitudes toward a green economy during the COVID-19 pandemic. The main hypothesis was that demographic factors determine attitudes toward a green economy in different ways, including the willingness to take actions in support of it, and acknowledgement of the connection of the need for green transformations with the pandemic.

Design. Subjects were given the questionnaire "Green Economy" which contains 19 statements with which they needed to express their degree of agreement on a 5-point Likert scale. Potential determinants of their attitudes toward a green economy were collected using an additional questionnaire, which included indicators of gender, age, family and professional status, religiosity, income level, education level, and place of residence (locality). The study involved 874 respondents from the Russian Federation (62.4% female; 37.6% male; the average age was 37.34 years).

Results. The results of a regression analysis showed that women, people with increased religiosity (but not too religious), younger people, and students and employees of public organizations (as opposed to employees of state and commercial organizations), as well as people from small towns or rural areas, were more positive about the idea of transition to a green economy.

Keywords:

Attitudes toward a green economy, COVID-19 pandemic, the "Green Economy" questionnaire, environmental attitudes, pro-environmental behavior

Conclusion. The belief that the pandemic situation has reinforced the need for a transition to a green economy was influenced by gender, degree of religiosity, and place of residence. Women, to a greater extent than men, as well as people who were more religious and lived in small towns and rural areas, were more acutely aware of the impact of the pandemic on the actualization of environmental problems.

Introduction

The increase in emissions polluting the environment, climate change, and other global environmental problems make the issue of transition to a green economy extremely topical. The term “green” connotes a new look at the development of human well-being through the construction of a new ecological civilization in the world (Liao, 2017). Historical responsibility for the state of the environment is a criterion for self-consciousness, reflecting the “maturity” of such a civilization (Valkovskaya, 2017, p. 219). Researchers call for social and environmental responsibility by business, based on the concept of sustainable development and the need for implementation of a consistent state environmental policy (Uskova & Kopytova, 2018) to strengthen institutional support for the transition to a green economy (Kozhevnikov & Lebedeva, 2019). Some scholars believe that the main objective of a “green” economy is not the greening of the technological base, but the greening of consciousness, both of the population (Khaliy, 2015), and, above all, of specialists, managers, and authorities (Lebedev, 2015; Thirnadtsatko, 2022).

Although there is no single definition of a “green” economy, this paradigm usually reflects three goals: improving resource efficiency; ensuring ecosystem sustainability; and strengthening social justice (Speck & Zoboli, 2017).

Despite the urgency of the need to create a green economy, many scientists question the economic efficiency of such a transition and its feasibility (Schmalensee, 2012; Ehresman & Okereke, 2015; Barrier, 2016). Their arguments include: 1) violations of green laws by the elite (Montefrio & Dressler, 2016); 2) data on the use of resources and carbon emissions (Hickel & Kallis, 2020); 3) low wages and little social protection for jobs created in the field of alternative energy (Chen & Li, 2021) and other negative social consequences (Dauvergne & LeBaron, 2013); 4) low productivity in green economy sectors in the cities with low per capita income (Wang, Hu, & Li, 2021); 5) reduced productivity in the industries with an increase in the share of “green” employment (Elliott & Lindley, 2017); 6) unwillingness to reduce consumption against the background of technical and organizational progress (Sanne, 2020); 7) “double dividends” from green taxation in the presence of unemployment (Fitz-Roy & Smith, 2004); and 8) the risk of increasing poverty (Rutskiy & Filippov, 2022), in particular in agricultural areas (Barbier, 2016).

Many factors influencing the creation of a green economy are being studied: namely, environmental innovations (Speck & Zoboli, 2017); open circulation of “green” knowledge (Speck & Zoboli, 2017; Guo et al., 2014); availability of financial resources for long-term investment (Speck & Zoboli, 2017; Winnett & Lewis, 2020); fiscal reforms (Speck & Zoboli, 2017); legislative changes such as introduction of “green” public procurement (Diofasi-Kovacs & Valko, 2017; Pasnicu & Ciuca, 2020);

and green taxes (Sanne, 2020). At the same time, insufficient attention is being paid to psychological factors in this area, such as people's attitudes toward a green economy and willingness to support it with real actions. Despite the fact that some scientists call for changing people's thinking in order to achieve a "green" economy (e.g., Speck & Zoboli, 2017), there are few real studies of such factors.

In addition, there is some thought that the economic problems caused by the COVID-19 pandemic have exacerbated the existing contradictions in the green sphere (Streimikiene & Kaftan, 2021; Chen et al., 2020; Kaur & Kaur, 2021; Lahcen et al., 2020; Goenka, Liu & Nguyen, 2021; Rutskiy & Filippov, 2022). Some researchers consider the pandemic as a condition and incentive for the development of a green economy (Gawel & Lehmann 2020; Barbier, 2020); others warn about its negative impact on the environment due to the contradiction between the objectives of economic growth (the effect of higher productivity and greater labor supply) and the principles of a green economy (Lahcen et al., 2020; Goenka, Liu, & Nguyen, 2021). However, the attitude of the population toward this issue is still insufficiently studied. In particular, we agree with those who note the lack of research on the impact of Covid-19 on environmental consciousness and behavior, both in Russia and abroad (Mdivani & Alexandrova, 2021).

The purpose of this study was to identify the determinants of attitudes toward a green economy during the COVID-19 pandemic in the Russian population. Our main hypothesis was that demographic factors would determine attitudes toward a green economy in different ways, including the willingness to take actions in support of it, as well as acknowledging the connection of the need for green transformations with the pandemic.

Methods and sample

The "Green Economy" questionnaire was used as our main tool. The questionnaire is based on 17 Sustainable Development Goals, which would form new requirements for the key components of a green economic system: production, exchange, distribution, and consumption. These statements are supplemented by expressions about the relationship between the green economy and the pandemic. The questionnaire contains 19 statements with which respondents needed to express their degree of agreement on a 5-point Likert scale (1 = "I do not agree at all; 2 = "I rather disagree"; 3 = "I find it difficult to answer"; 4 = "I rather agree"; 5 = "I completely agree").

Potential determinants of attitudes towards the green economy were collected using another questionnaire survey, which collected indicators of gender, age, family and professional status, religiosity, income level, education level, and place of residence (locality) of the participants.

To identify the contribution of the demographic indicators to the formation of a positive attitude toward a green economy, regression analysis was used. To compare the intensity of the attitudes toward a green economy in different categories of the population, a one-factor analysis of variance was used.

The study involved 874 respondents from the Russian Federation, 62.4% female, and 37.6% male. The age of the respondents ranged from 15 to 77 years, while the average age was 37.34 years. Subjectively, 0.9% of the respondents rated their income as "very high," 3% as high, 56.3% as average, 33.0% as low, and 6.9% as very low. When asked about religiosity, 1.5% of the respondents considered themselves very religious,

30.3% quite religious, 45.5% not very religious, and 22.7% not religious at all. As to the level of education, 18.4% of the respondents had a secondary education, 14.3% an incomplete higher education, and 44.1% higher education (bachelor's or specialist's degree). Additionally, 16.6% had completed a master's degree, and 6.6% had a scientific degree. The marital status of the respondents was: 46.5% officially married, 11.7% living with a partner, 10.6% divorced, 27.8% single, 2.5% widowed, and 0.9% married but living separately.

Results

The confirmatory factor analysis resulted in the final (a posteriori) model of the respondents' attitudes toward a green economy, which consisted of three factors: positive attitudes toward a green economy, the connection of a green economy with the pandemic, and support for a green economy with real actions (*Figure 1*). The model corresponded well to the initial data on the indicators of the indices: CMIN = 545.308; $df = 87$; $p = 0.000$; GFI = 0.928; CFI = 0.927; RMSEA = 0.078. The estimated parameters of the model turned out to be statistically reliable: regression coefficients ($p < 0.001$); variance of latent variables (scales) ($p < 0.001$); and covariances (correlations) between errors ($p < 0.01$). Correlations between all the scales also showed statistical validity ($p < 0.01$).

The first factor, which was the most significant and defined as "Positive attitudes toward the green economy," combined the variance of agreement with the following numbered statements: "I support the principle of a green economy, according to which natural resources should go to our descendants" (No. 11); "I am convinced that the concept of a green economy supports the conservation of resources and the reduction of negative impacts on nature" (No. 10); "I believe the transition to a green economy is morally correct" (No. 16); "Countries should introduce coefficients that evaluate overall well-being based not only on monetary income and expenditure, but also on energy and environmental factors" (No. 5); "I approve the introduction of an international system for assessing natural and human capital in enterprises" (No. 12); "I believe that the costs of introducing green technologies will pay off in the future" (No. 19); "I am ready by my actions to support public initiatives aimed at preventing a pandemic and other global threats" (No. 6); "Businesses should start adopting green technologies, regardless of their cost" (No. 4); and "In order to survive during a pandemic, humanity will have to unite and learn to negotiate in the face of a common danger." (No. 18)

The second factor, called the "Connection of the green economy with the pandemic." included responses to the following statements: "During and after the pandemic, companies need to move from focusing only on profit to caring also about the environment" (No. 1); "The only alternative to the development of the economy against the backdrop of a pandemic is an environmentally oriented economy" (No. 2); and "The pandemic should give impetus to increased investment in the environment, environmental research, and technology." (No. 3)

The third factor, labeled "Support for the green economy by real actions," included the variance for the following statements: "I am ready to sign public appeals on the Internet aimed at preventing a pandemic, drawing attention to climate change, introducing green technologies" (No. 7); "I am ready to donate money for the conser-

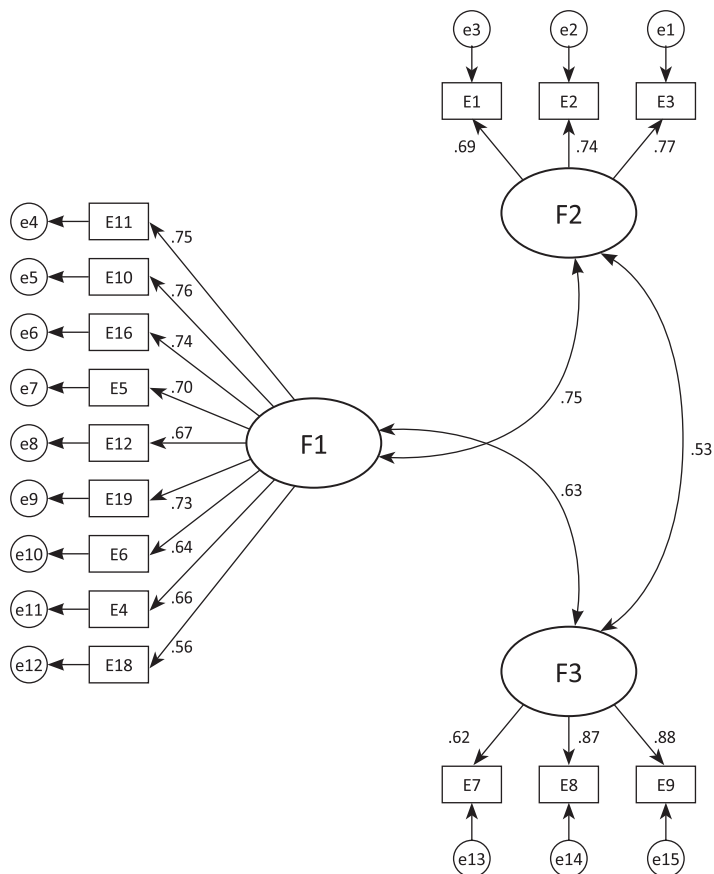

Figure 1. Structural model of the questionnaire based on the results of confirmatory analysis

Note. F — factors, E — variances of agreement with the statements of the questionnaire, e — errors of variables

vation of nature, if I am sure that it will be used for their intended purpose” (No. 8); and “I am ready to donate money to funds whose main goal is to prevent pandemics, combat environmental pollution, and preserve biodiversity on the planet.” (No. 9)

It should be noted that some of the statements did not gain the necessary weight to be included in the analysis, so they were excluded. They were: (No. 13) “I have doubts that a ‘green’ economy will contribute to the eradication of poverty, increase the country’s competitiveness and growth in key sectors;”(No. 14)“A ‘green’ economy is a socially just economy;”(No. 15)“I have confidence in the implementation of the principles of a green economy;” and (No. 17) “I have never worried about global risks (such as global epidemics, climate change, depletion of world resources, etc.)”. We assumed that the reason lay in the formulation of the statements. For example, statements 13 and 17 are formulated in a negative form and could be less clear to the respondents. Statements 14 and 15 are probably too idealized; they touch on such phenomena as trust and justice, which could be hard to assess.

On checking the reliability of the scales based on the internal consistency of their statements, the Cronbach's coefficients showed acceptable levels of reliability: "Positive attitudes towards the green economy" ($\alpha = 0.890$); "The connection of the green economy with the pandemic" ($\alpha = 0.778$); and "Support for the green economy with real actions" ($\alpha = 0.819$).

Next, we examined which demographic variables might act as determinants of the participants' attitudes toward a green economy. To do this, the value of each scale was calculated, and was then added as an independent variable to the regression analysis.

The results of the regression analysis showed that variables of gender, religiosity, age, professional sphere, and place of residence (type of settlement) contributed to a positive attitude towards the green economy ($R = .238$; $R^2 = .057$) (See *Table 1*).

Table 1

Regression coefficients: dependent variable - positive attitude toward a green economy

Model	Non-standardized coefficients		Standardized coefficients	t	p
	B	Standard error	Beta		
1 (Constant)	3.933	.030		130.183	.000
Gender	-.248	.049	-.168	-5.037	.000
2 (Constant)	4.223	.094		44.799	.000
Gender	-.238	.049	-.161	-4.838	.000
Religion	-.102	.031	-.108	-3.249	.001
3 (Constant)	4.395	.114		38.413	.000
Gender	-.224	.049	-.152	-4.550	.000
Religion	-.098	.031	-.104	-3.121	.002
Age	-.005	.002	-.088	-2.636	.009
4 (Constant)	4.316	.121		35.713	.000
Gender	-.243	.050	-.165	-4.852	.000
Religion	-.101	.031	-.108	-3.246	.001
Age	-.005	.002	-.090	-2.693	.007
Occupation	.048	.024	.068	2.003	.045
5 (Constant)	4.110	.156		26.346	.000
Gender	-.235	.050	-.159	-4.682	.000
Religion	-.101	.031	-.108	-3.251	.001
Age	-.005	.002	-.078	-2.316	.021
Occupation	.053	.024	.075	2.210	.027
Place of residence	.062	.030	.070	2.080	.038

The results of the regression analysis showed that women, people with increased religiosity (but not too religious), younger people, and students and employees of public organizations (as opposed to employees of state and commercial organiza-

tions), as well as people from small towns or rural areas, were the most positive about the idea of transition to a green economy.

Next, we explored the determinants of the belief in the connection between the green economy and the pandemic caused by the coronavirus (Table 2).

Table 2

Regression coefficients: dependent variable — the relationship between the pandemic and a green economy

Model	Non-standardized coefficients		Standardized coefficients	t	p
	B	Standard error	Beta		
1 (Constant)	3.666	.037		99.114	.000
Gender	-.329	.060	-.181	-5.446	.000
2 (Constant)	4.083	.115		35.457	.000
Gender	-.313	.060	-.173	-5.223	.000
Religion	-.146	.038	-.127	-3.821	.000
3 (Constant)	3.884	.153		25.401	.000
Gender	-.300	.060	-.165	-4.968	.000
Religion	-.145	.038	-.126	-3.796	.000
Place of residence	.071	.036	.065	1.970	.049

Table 3

Regression coefficients: dependent variable — willingness to act in support of a green economy

Model	Non-standardized coefficients		Standardized coefficients	t	p
	B	Standard error	Beta		
1 (Constant)	3.804	.108		35.338	.000
Age	-.014	.003	-.173	-5.180	.000
2 (Constant)	4.288	.162		26.424	.000
Age	-.014	.003	-.165	-4.986	.000
Religion	-.175	.044	-.131	-3.962	.000
3 (Constant)	4.152	.171		24.225	.000
Age	-.014	.003	-.169	-5.105	.000
Religion	-.183	.044	-.137	-4.137	.000
Occupation	.080	.033	.080	2.405	.016
4 (Constant)	4.144	.171		24.265	.000
Age	-.013	.003	-.160	-4.831	.000
Religion	-.177	.044	-.133	-4.018	.000
Occupation	.098	.034	.097	2.883	.004
Gender	-.193	.071	-.092	-2.733	.006

The belief that the pandemic situation reinforced the need for a transition to a green economy was influenced by gender, degree of religiosity, and place of residence. Women, to a greater extent than men, as well as people who were more religious and lived in small towns and rural areas, were more acutely aware of the impact of the pandemic on the actualization of environmental problems ($R = .230$; $R^2 = .053$).

Next, we studied which variables influenced people's willingness to support the principles of a green economy with real actions (*Table 3*).

According to the results of the regression analysis, the willingness to take real actions in support of a green economy depended on age, level of religiosity, professional status, and gender ($R = .248$; $R^2 = .061$). Younger people with increased religiosity, mostly women, as well as students and employees of public organizations (as opposed to employees of state and commercial organizations), were the most willing to act in support of a green economy.

Thus, the main determinants predicting a positive attitude towards the green economy were female gender, younger age (students), and a high (but not very high) level of religiosity, as well as the relatively small size of place of residence, and belonging to a public organization. Variables such as education level, family status, and income level did not directly affect the shaping of a positive attitude towards a green economy. The main hypothesis was partially confirmed: the level of religiosity was a constant predictor of all measured parameters, while gender, age, place of residence, and type of organizational affiliation varied.

Discussion

Analyzing the data obtained from the point of view of compliance with previous studies, we found that the determinants we identified largely corresponded to the factors of environmental attitudes and pro-environmental behavior they found. In particular, our results were consistent with data on the influence of gender, age (Emelyanova, Nestik, & Belyh, 2019), and religiosity (Ahmad et al., 2012) on environmental attitudes and behavior. Our results do not contradict the results of other authors on the relationship between environmental consciousness and the respondents' ideas about Covid-19 (Mdivani & Alexandrova, 2021), which indicated that the attention of the younger generation is more focused on the consequences of the human impact on nature (ecocentric type), while representatives of the older generation are more concerned about the negative impact of nature on humans (archaic type).

Our study allows us to make two important generalizations. First, the fact that the pandemic has exacerbated the need for a transition to a green economy was confirmed not only by external (economic) calculations, but also by internal factors. In the minds of many people, the pandemic and the issue of establishing a green economy appeared related. Such a relationship leads to the civilizational issue of preserving oneself as a biological species (*homo sapiens*) in the face of violations of the ecological balance of the planet caused by our species (Panov, 2017).

Second, the fact that the willingness to take real actions in support of the green economy was a separate, relatively small factor may point to a gap between the declared belief in the correctness of green principles, and the willingness to implement them. This fact can become a powerful deterrent force in the implementation of green

reforms. Other authors have also noted the insufficient activity of Russians in matters of environmental protection (Dushkova & Kirilov, 2017), as well as a low level of ecological culture, which is distinguished by fragmentation, distance, and inconsistency of its components (Kurbanov & Prokhoda, 2019).

Therefore, when solving such a strategic task as improving environmental education and enlightenment (Dukhanina & Maksimenko, 2019), it is important to combine the transmission of knowledge with the development of skills, combining information with involvement in pro-environmental behavior as expressed in the theory of pushing (Thaler & Sunstein, 2008). Environmental education also involves the development of spiritual activity and moral consciousness. In scientific research, it is advisable to strengthen the general tendency to integrate the solution of practical problems with the need for theoretical understanding of the constructs and models of environmental behavior (Morozova & Kozlov, 2020). To solve environmental problems in practice, it is important to remove the contradictions between the declared goals of environmental and economic development stated in the legal documents and the lack of development of institutional support for their implementation (Kozhevnikov & Lebedeva, 2019).

Conclusion

The results of our study enrich science with the latest data on the determinants of Russian attitudes toward a green economy during the COVID-19 pandemic, and also indicate an increase in pro-environmental sentiment in connection with the epidemic. The study's findings about the influence of gender, age, level of religiosity, the size of the residential location, and the type of work organization in the shaping of a positive attitude toward a green economy and willingness to act in its support contribute to the development of environmental psychology.

The data obtained should be taken into account when developing state programs for the transition to a green economy. In particular, it is necessary to address a certain inertia of the population in taking concrete steps along this path. The main driver for dealing with this issue may be the younger generation, especially the female part of it, which shows itself to be more sensitive to environmental problems. Increasing the level of religiosity of the population can also become a key factor involved in the green transformation. On the contrary, an increase in atheistic sentiments in the society can become a barrier to the introduction of green technologies. The transition to a green economy is easier to implement in small towns and villages, where people perceive its basic principles more positively and readily.

Our study contributes to the development of the ideas about the factors influencing the transition to a green economy in a country with an emerging economy, with a focus on some demographic variables as predictors of the positive attitude toward a green economy.

The main limitations of the study included the use of the survey methods only, which may not provide completely objective data. The results can be extrapolated to countries with growing economics, but can be applied with limitations to the countries with developing and developed economics. In addition, the results could have been influenced by the factor of the economic culture of the country, so in the future it is necessary to supplement the study with facts from other countries (cultures).

Author Contributions

A.A. Maksimenko and O.S. Deyneka conceived of the idea and supervised the project, and O.S. Deyneka and E.V. Zabelina designed the experiment. E.V. Zabelina conducted the statistical analysis. All authors discussed the results and contributed to the final manuscript.

Conflict of Interest

The authors declare that they have no known competing financial interests or personal relationships that could have appeared to influence the work reported in this paper.

Ethics Statement

The study was carried out in accordance with the Declaration of Helsinki and the existing Russian and international regulations concerning ethics in research. All participants provided written informed consent.

Acknowledgments

This research was supported by Russian Science Foundation (Project №22-28-01935).

References

- Ahmad, J., Ali, I., Grigore, G.F., & Stancu, A. (2012). Studying consumers' ecological consciousness — a comparative analysis of Romania, Malaysia, and Pakistan. *Amfiteatru economic*, 14(31), 84–98.
- Barbier, E.B. (2020). Greening the Post-pandemic Recovery in the G20. *Environmental and Resource Economics*, 76, 685–703. <https://doi.org/10.1007/s10640-020-00437-w>
- Barrier, E.B. (2016). Building the Green Economy. *Canadian Public Policy*, 42, 1–9. <https://doi.org/10.3138/cpp.2015-017>
- Chen, Y., & Li, A. (2021). Global Green New Deal: A Global South perspective. *The Economic and Labour Relations Review*, 32(2), 170–189. <https://doi.org/10.1177/10353046211015765>
- Chen, Z.Q., Marin, G., Popp, D., & Vona, F. (2020). Green Stimulus in a Post-pandemic Recovery: the Role of Skills for a Resilient Recovery. *Environmental and Resource Economics*, 76(4), 901–911. <https://doi.org/10.1007/s10640-020-00464-7>
- Dauvergne, P., & LeBaron, G. (2013). The Social Cost of Environmental Solutions. *New Political Economy*, 18(3), 410–430. <https://doi.org/10.1080/13563467.2012.740818>
- Diófási-Kovács, O., & Valkó, L. (2017). Transition to Green Economy: Green Procurement Implementation Strategies Experiences from Hungarian Public and Private Organizations. In W. Leal Filho, D.M. Pociovalisteanu, & A. Al-Amin (Eds.), *Sustainable Economic Development*. World Sustainability Series. Springer, Cham. https://doi.org/10.1007/978-3-319-45081-0_14
- Dukhanina, L.N., & Maksimenko, A.A. (2019). Enlightenment Demands of Russians. *Voprosy Obrazovaniya / Educational Studies Moscow*, 2(June), 226–240. <https://doi.org/10.17323/1814-9545-2019-2-226-240>
- Dushkova, D., & Kirilov, S. (2017). Ekologizaciia soznaniia kak odin iz printsipov ekologicheskoi politiki [Ecological Consciousness as One of the Main Principles of Ecological Policy]. *Vestnik Volgogradskogo gosudarstvennogo universiteta Serii 3. Ekonomika Ekologija* [Bulletin of the Volgograd State University. Series 3. Economics. Ecology], 19(2), 148–158. <https://doi.org/10.15688/jvolsu3.2017.2.15>
- Ehresman, T.G., & Okereke, C. (2015). Environmental justice and conceptions of the green economy. *International Environmental Agreements*, 15(1), 13–27. <https://doi.org/10.1007/s10784-014-9265-2>
- Elliott, R.J.R., & Lindley, J.K. (2017). Environmental Jobs and Growth in the United States. *Ecological Economics*, 132, 232–244. <https://doi.org/10.1016/j.ecolecon.2016.09.030>

- Emelyanova, T.P., Nestik, T.A., & Belykh, T.V. (2019). Otnoshenie k ekologicheskim riskam sredi predstavitelei pokoleniy Y i Z [Attitude to environmental risks among generations Y and Z]. *Institut psikhologii Rossiyskoy akademii nauk. Sotsial'naiia i ekonomicheskaia psikhologiya* [Institute of Psychology of the Russian Academy of Sciences. Social and Economic Psychology], 4/3(15), 62–82.
- FitzRoy, F., & Smith, I. (2004). Welfare, growth, and environment: A skeptical review. *The Skeptical Environmentalist* by B. Lomborg, 51(5), 707–717. <https://doi.org/10.1111/j.0036-9292.2004.00329.x>
- Gawell, E., & Lehmann, P. (2020). Killing Two Birds with One Stone? Green Dead Ends and Ways Out of the COVID-19 Crisis. *Environmental and Resource Economics (Dordr)*, 8, 1–5. <https://doi.org/10.1007/s10640-020-00443-y>.
- Goenka, A., Liu, L., & Nguyen, M.H. (2021). COVID-19 and a Green Recovery? *Economic Modeling*, 104, 105639. <https://doi.org/10.1016/j.econmod.2021.105639>
- Guo, X.R., Liu, H.F., Mao, X.Q., Jin, J.J., Chen, D.S., & Cheng, S.Y. (2014). Willingness to pay for renewable electricity: A contingent valuation study in Beijing, China. *Energy Policy*, 68, 340–347. <https://doi.org/10.1016/j.enpol.2013.11.032>
- Hickel, J., & Kallis, G. (2020). Is Green Growth Possible? *New Political Economy*, 25(4), 469–486. <https://doi.org/10.1080/13563467.2019.1598964>
- Kaur, N., & Kaur, A. (2021). Capitalist agriculture, COVID-19 and agrarian labour relations in Punjab, India. *Journal of Agrarian Change*, 21(3), 638–650. <https://doi.org/10.1111/joac.12428>
- Khaliy, I.A. (2015). Ecological consciousness of the population of modern Russia. *History and Modernity*, 1, 189–205.
- Kozhevnikov, S.A., & Lebedeva, M.A. (2019). Problems of transition to green economy in the region (based on materials of the European North of Russia). *Problems of Territorial Development*, 4(102), 72–88. <https://doi.org/10.15838/ptd.2019.4.102.4>
- Kurbanov, A.R., & Prokhoda, V.A. (2019). Ekologicheskaiia kul'tura: empiricheskaiia proektsiia (otnoshenie rossiian k izmeneniiu klimata) [Ecological culture: an empirical projection (attitudes of Russians towards climate change)]. *Monitoring obshchestvennogo mneniia : Ekonomicheskie i sotsial'nye peremeny* [Monitoring of Public Opinion: Economic and Social Changes], 4, 347–370. <https://doi.org/10.14515/monitoring.2019.4.17>
- Kwon, J., & Ahn, J. (2020). Socio-demographic characteristics and green consumption behavior in developing countries: the case of Malaysia. *Social Responsibility Journal*, 17, 8, 1213–1231. <https://doi.org/10.1108/SRJ-02-2020-0071>
- Lahcen, B., Brusselaers, J., Vrancken, K., Dams, Y., Paes, C.D., Eyckmans, J., & Rousseau, S. (2020). Green Recovery Policies for the COVID-19 Crisis: Modelling the Impact on the Economy and Greenhouse Gas Emissions. *Environmental & Resource Economics*, 76(4), 731–750. <https://doi.org/10.1007/s10640-020-00454-9>
- Lebedev, Yu.V. (2015). Formirovanie nauchnoy bazy “zelionoy” ekonomiki [Formation of the scientific base of the “Green Economy”]. *Izvestiia Samarskogo nauchnogo tsentra Rossiiskoy akademii nauk* [Proceedings of the Samara Scientific Center of the Russian Academy of Sciences], 17, 5(2), 495–499.
- Liao, J.H. (2017). Connotation, Significance and Realization Way of “Green.” In X. Chen (Ed.), *Proceedings of the 3rd annual International Conference on Management, Economics and Social Development* (pp. 136–142) (icmesd 17).
- Mdivani, M.O., & Alexandrova, E.S. (2021). Pandemiia v kontekste ekologicheskogo soznaniia [Pandemic in the Context of an Environmental Consciousness]. *Ekspierimental'naiia psikhologiya = Experimental Psychology* (Russia), 14(3), 67–78. <https://doi.org/10.17759/exppsy.2021140305>
- Montefrio, M.J.F., & Dressler, W.H. (2016). The Green Economy and Constructions of the “Idle” and “Unproductive” Uplands in the Philippines. *World Development*, 79, 114–126. <https://doi.org/10.1016/j.worlddev.2015.11.009>
- Morozova, S.V., & Kozlov, V.V. (2020). Ekologicheskoe povedenie kak problema issledovaniia v otechestvennoy i zarubezhnoy psikhologii [Ecological Behavior as a Research Problem in Domestic and Foreign Psychology]. *Psikhologiya. Psikhofiziologiya* [Psychology. Psychophysiology], 13(1), 14–22. <https://doi.org/10.14529/jpps200102>
- Panov, V.I. (2017). Ekologicheskoe soznanie v paradigmat'nom kontekste poniatyia “priroda” [Environmental consciousness in the paradigm of the “nature” concept]. *Noosfernye issledovaniia. Mezh-*

- dunarodny mezhdistsiplinary nauchny zhurnal* [Noosphericstudies. International Interdisciplinary Scientific Journal], 2(18), 17–30.
- Pasnicu, D., & Ciuca, V. (2020). Green procurement implications on the labor market in the context of the transition to the green economy. *Amfiteatru Economic*, 22(53), 28–41. <https://doi.org/10.24818/EA/2019/53/28>
- Rutskiy, V.N., & Filippov, I.A. (2022). Vzaimosviaz' urovnia bednosti i faktorov zelenoy ekonomiki v stranah Evropeyskogo soiuzha [Relationship Between the Level of Poverty and the Factors of Green Economy in the Countries of the European Union]. *Finansovyy zhurnal* [Financial Journal], 14(1), 56–70. <https://doi.org/10.31107/2075-1990-2022-1-56-70>
- Sanne, C. (2000). Dealing with environmental savings in a dynamical economy — how to stop chasing your tail in the pursuit of sustainability. *Energy Policy*, 28(6–7), 487–495. [https://doi.org/10.1016/S0301-4215\(00\)00031-8](https://doi.org/10.1016/S0301-4215(00)00031-8)
- Schmalensee, R. (2012). From “Green Growth” to sound policies: An overview. *Energy Economics*, 34, 2–6. <https://doi.org/10.1016/j.eneco.2012.08.041>
- Speck, S., & Zoboli, R. (2017). The Green Economy in Europe: In Search for a Successful Transition. In S. Shmelev (Ed.), *Green economy reader: lectures in ecological economics and sustainability* (pp. 141–160). https://doi.org/10.1007/978-3-319-38919-6_7
- Streimikiene, D., & Kaftan, V. (2021). Green finance and the economic threats during COVID-19 pandemic. *Terra Economicus*, 19(2), 105–113. <https://doi.org/10.18522/2073-6606-2021-19-2-105-113>
- Thaler, R.H., & Sunstein, C.R. (2008). *Nudge: Improving Decisions About Health, Wealth and Happiness*. Yale University Press, New Haven, 293.
- Trinadtsatko, O.A. (2022). Ekologicheskoe soznanie kak element sotsial'no ekologicheskogo upravleniia [Ecological consciousness as an element of socio-ecological management]. *Sotsial'no-gumanitarnye znaniia* [Social and humanitarian knowledge], 4, 127–140. <https://doi.org/10.34823/SGZ.2022.4.518873>
- Uskova, T.V., & Kopytova, E.D. (2018). Vektor ekologizatsii sovremennoy ekonomiki Rossii: problemy i napravleniia ih resheniia [Ecologization of modern Russian economy: Problems and ways to solve them]. *Vestnik Permskogo universiteta. Seria Ekonomika* [Perm University Herald. Economy], 13(1), 37–57. <https://doi.org/10.17072/1994-9960-2018-1-37-57>
- Valkovskaya, V.V. (2017). Dialektika social'nyh idealov i ekologicheskikh cennostey [Dialectics of social ideals and ecological values]. *Vlast' i upravlenie na Vostoke Rossii* [Power and Administration in the East of Russia], 4(81), 216–222. <https://doi.org/10.22394/1818-4049-2017-81-4-216-222>
- Wang, A.L., Hu, S., & Li, J.L. (2021). Does economic development help achieve the goals of environmental regulation? Evidence from partially linear functional-coefficient model. *Energy Economics*, 103, 105618. <https://doi.org/10.1016/j.eneco.2021.105618>
- Winnett, A., & Lewis, A. (2000). “You’d have to be green to invest in this”: Popular economic models, financial journalism, and ethical investment. *Journal of Economic Psychology*, 21(3), 319–339. [https://doi.org/10.1016/S0167-4870\(00\)00007-6](https://doi.org/10.1016/S0167-4870(00)00007-6)
- Zavali, M., & Theodoropoulou, H. (2018). Investigating determinants of green consumption: evidence from Greece. *Social Responsibility Journal*, 14(4), 719–736. <https://doi.org/10.1108/SRJ-03-2017-0042>

Original manuscript received June 16, 2022

Revised manuscript accepted March 9, 2023

First published online March 30, 2023

To cite this article: Maksimenko, A.A., Deyneka, O.S., Zabelina, E.V. (2023). Determinants of Russian Attitudes Toward a Green Economy During the Covid-19 Pandemic. *Psychology in Russia: State of the Art*, 16(1), 113–124. DOI: 10.11621/pir.2023.0107